

The RFIZ series are flexible current transformers based on the principle of Rogowski coils, flexible rope-like air coils, which can be connected around the conductor when it is "live". Compared with traditional split and solid-core CTs, they are easier to install and measure. With their flexible design and light weight, they are very suitable for bus bars and irregularly shaped multi-core wiring harnesses. Rogowski coil technology has low phase shift error, inductance and excellent linearity, while being largely unaffected by electromagnetic interference and pulsed DC, thus providing high accuracy. RFIZ series coils can be used for single-phase and three-phase measurement applications. The built-in voltage integrator can simplify the wiring installation, can output 0 to 2V AC voltage, and the rated input can be selected between 30A~10kA.

Features

- Flexible and lightweight
- No danger from open-circuited secondary
- High secondary output voltage & precise linearity error
- Easy & quick installation on uninterruptible power lines
- In progress of certification for CE complying
- IP65, IP67
- aperture from 80 to 300 mm

Application

- Very high current monitoring
- DC ripple measurement
- Harmonics and transients monitoring
- Power monitoring & control systems
- Applicable in electronic Watt-hour meter

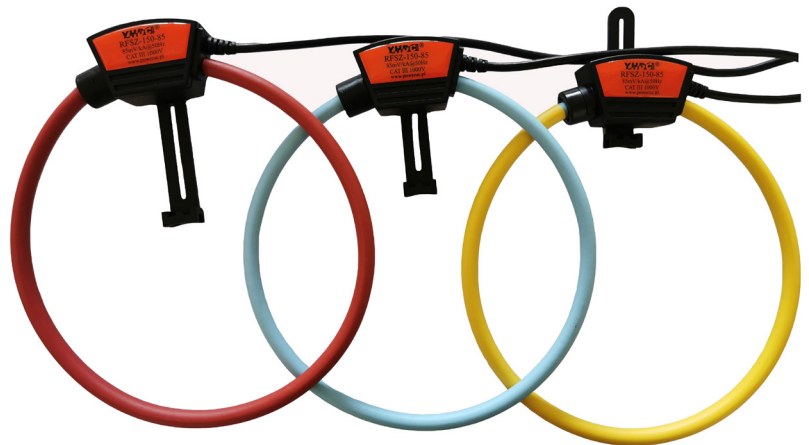

Specification

Model	RFIZ-80-xx	RFIZ-105-xx	RFIZ-150-xx	RFIZ-180-xx	RFIZ-240-xx	RFIZ-300-xx
Coil Length	293mm	363mm	493mm	593mm	723mm	943mm
Window Diameter Size	80mm	105mm	150mm	180mm	240mm	300mm
Rated current	30A,50A,100A,150A,200A,250A,300A,400A,500A,600A,800A,1KA,1.2KA,1.5KA,2KA,2.4KA,2.5KA,3KA,4KA,5KA,6KA,8KA,10KA					
Accuracy	<1% typical at 5% to 120% of rated current (25°C)					
Positioning error	±1%					
Output Voltage	333mV AC, 1V AC, 2V AC					
Power Requirement	+12V DC					
Frequency Range	10Hz to 20kHz					
Linearity	±0.2%					
Phase Shift	≤0.5°					
Connection cable Type	4 x 0.2 mm					
Connection cable	Normal 190cm (as required)					
Operating temperature	from -30°C to +80°C					
Storage temperature	from -40°C to +80°C					
Working voltage	1000 VRMS CAT III 600 VRMS CAT IV					
Test voltage	7400 VRMS / 1 min					
Material	Thermoplastic rubber UL94-V0					
Protection degree	IP67					

Dimensions

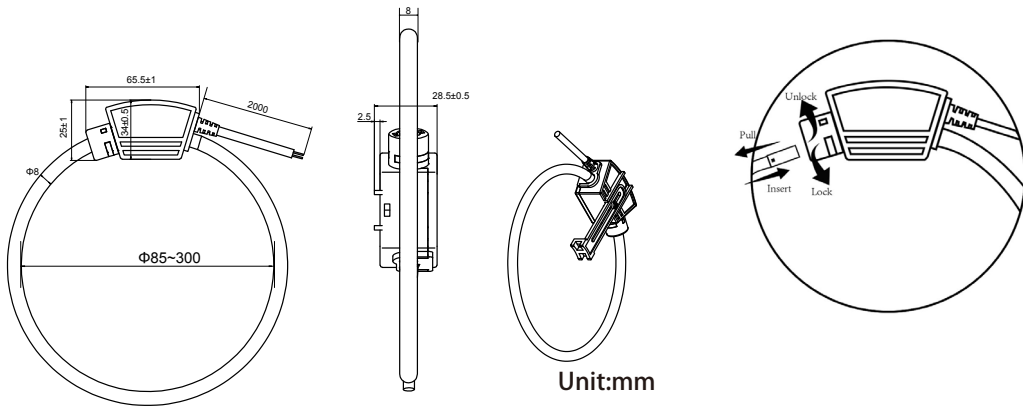

Connection

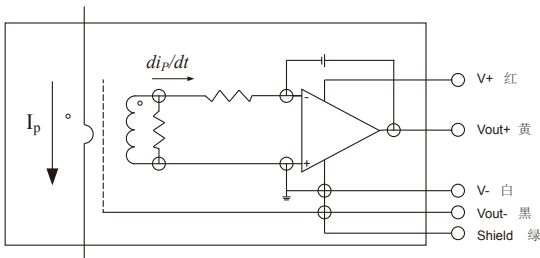

WARNING!

Do not stress the coil by applying any kind of mechanical force (ie. twisting, puncturing, excessive pressure, tight bending, etc.) which will dramatically degrade the device's accuracy.