

## Hall voltage sensor

Sub-plate installation, Crimping terminal output. Detect DC, AC and pulse current, High insulation between primary side and the vice side circuit.

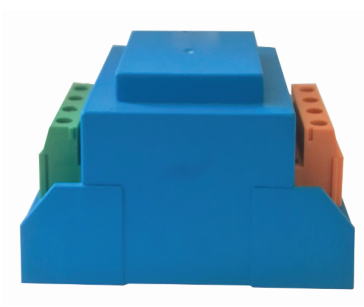
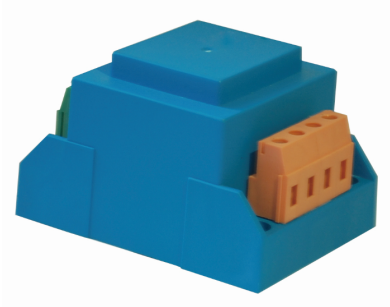

zero gain

### Product features

- Low power consumption
- Good linearity
- No insertion loss
- Fast response time
- Good anti-interference ability

### Product application

- Railway
- Metallurgical
- Welding machine
- Robot
- Motor
- Inverter power supply
- Variable frequency governor
- Uninterrupted power supply and communication power supply

High side after wiring  
Terminal proposal seal processing

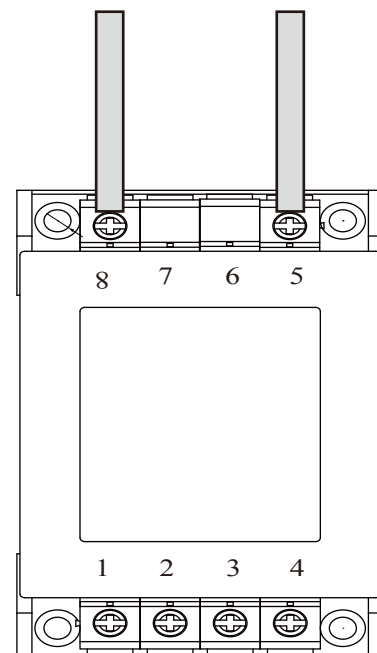

**Electrical parameters:** ( The following parameters are typical values and actual values will be subject to product testing )

**Remarks:**

$I_{PN}$	Rated input	$\pm 50V$	$\pm 100V$	$\pm 200V$	$\pm 300V$	$\pm 400V$	$\pm 500V$	Standard input
$I_{pm}$	Input measurement range	$\pm 75V$	$\pm 150V$	$\pm 300V$	$\pm 450V$	$\pm 600V$	$\pm 750V$	Default is 1.5 times of rated input
$V_{out}$	Rated output	2.5V $\pm$ 0.625V						Standard output
X	Accuracy	1%						$I = I_{PN}$
$\epsilon_L$	Linearity	0.2%						$I = 0 \sim \pm I_{PN}$
$V_C$	Supply voltage	+5V						Supply voltage range $\pm 5\%$
$I_C$	Current consumption	$\leq 20mA + I_s$						Reference will be subject to the measured
Rl	Load impedance	$\geq 10K \Omega$						Collection port impedance while lower voltage affect accuracy
$V_{oe}$	Zero offset voltage	$\leq \pm 30mV$						TA=25°C
$T_r$	Response time	40~200 $\mu s$						Reference will be subject to the measured
$N_w$	Weight	185g						Reference will be subject to the measured
$T_a$	Operation temperature	-10~+70°C						
$T_s$	Storage temperature	-25~+70°C						
Bw	Band width	-						Factory test according to DC
$V_d$	Delectric strength	3.5KV 50Hz 1min						

**Factory commissioning :**

**Calculation formula: 2.5V $\pm$ 0.625V 0V datum**

1. Debugging with 0V as the reference point(acquiescence) Forward direction:  $2.5 + (I/I_{PN}) * 0.625$
2. Debug with Vref as the reference point(optional) Reverse direction:  $2.5 - (I/I_{PN}) * 0.625$

**Instruction for use:**

1. Correct wiring as indicated
2. Full scale measurement, response time and following the speed for the best
3. Faulty wiring can lead to product damage and output uncertainty

**Safe operation:**

- \*Please read this specification carefully before use.
- \*When you need to move the product, please be sure to disconnect the power and all the connected cables.
- \*If found shell, devices attached to the fixed parts, wire, or have any damaged, please immediately deal with hidden dangers.
- \*If there is any doubt about the safe operation of the equipment, the equipment and the corresponding accessories should be closed immediately, and the fastest time for troubleshooting.

**Proclamations:**

As our products are constantly being improved and updated, we reserve the right to modify the content of this specification at any time without prior notice.

Dimensions(in mm±0.5) :

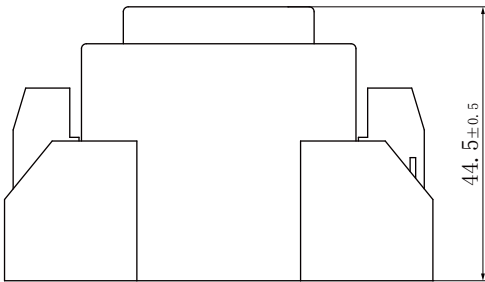

Side view

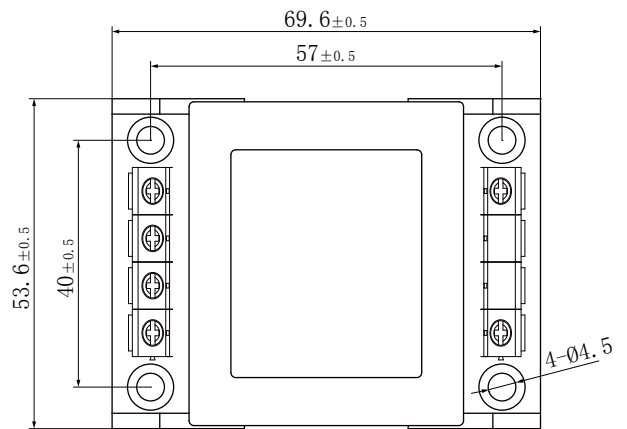

Top view

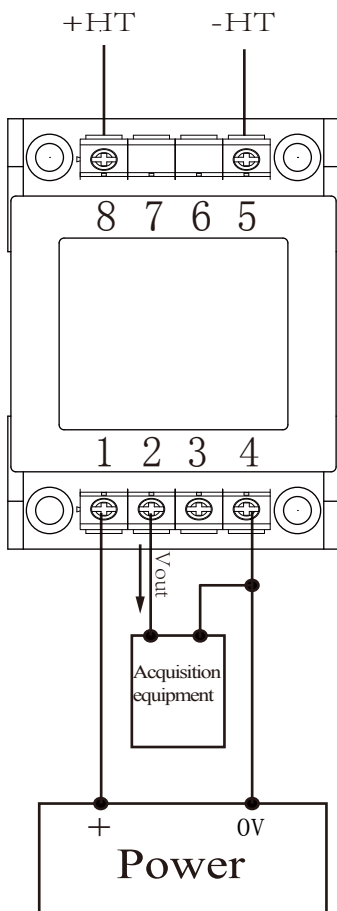

**Terminal definition:**

- 1: +V
- 2: Vout
- 3: Vref
- 4: 0V
- 5: -HT
- 6: Air terminal
- 7: Air terminal
- 8: +HT

※Detection:

- ① Choose the auxiliary power supply with small ripple ( $\leq 10\text{mV}$ )
- ② Switch on auxiliary power
- ③ The auxiliary power is connected to the sensor
- ④ The sensor detects the primary current