

Hall open loop current sensor

PCB mounting, Detect DC, AC and pulse current, High insulation between primary side and the vice side circuit.



Front view



Epoxy view

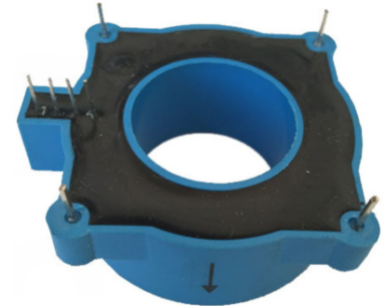

Bottom view

Product features

- Light weight
- Low power consumption
- Good linearity
- No insertion loss
- Fast response time
- Good anti-interference ability

Installation diagram

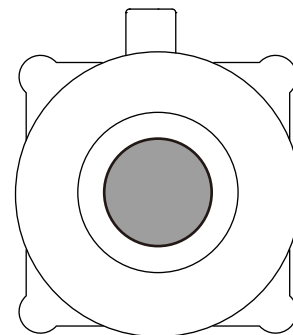

Product application

- Railway
- Metallurgical
- Welding machine
- Robot
- Motor
- Inverter power supply
- Variable frequency governor
- Uninterrupted power supply and communication power supply

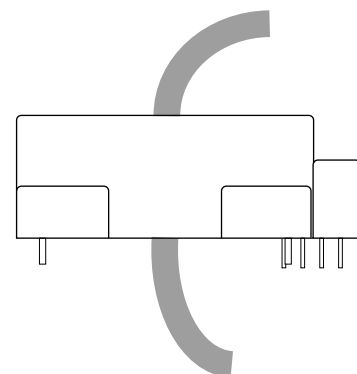

Electrical parameters: (The following parameters are typical values and actual values will be subject to product testing)

Remarks:

| | | | | | | |
|--------------|-------------------------|------------------------|------------|------------|-------------|--|
| I_{PN} | Rated input | $\pm 200A$ | $\pm 400A$ | $\pm 600A$ | $\pm 800A$ | Standard input |
| I_{pm} | Input measurement range | $\pm 300A$ | $\pm 600A$ | $\pm 900A$ | $\pm 1200A$ | Default is 1.5 times of rated input, and maximum $\leq 1200A$ (saturation) |
| V_{out} | Rated output | 2.5V \pm 1.25V | | | | Standard output |
| X | Accuracy | 1% | | | | $I = I_{PN}$ |
| ϵ_L | Linearity | 1% | | | | $I = 0 \sim \pm I_{PN}$ |
| V_c | Supply voltage | +5V | | | | Supply voltage range $\pm 5\%$ |
| I_c | Current consumption | $\leq 15mA$ | | | | Reference will be subject to the measured |
| Rl | Load impedance | $\geq 10K \Omega$ | | | | Collection port impedance while lower voltage affect accuracy |
| V_{oe} | Zero offset voltage | $\leq \pm 15mV$ | | | | $T_A = 25^\circ C$ |
| T_r | Response time | $\leq 5 \mu s$ | | | | Reference will be subject to the measured |
| N_w | Weight | 53g | | | | Reference will be subject to the measured |
| T_a | Operation temperature | $-40 \sim +80^\circ C$ | | | | |
| T_s | Storage temperature | $-40 \sim +80^\circ C$ | | | | |
| Bw | Band width | DC \sim 10KHz | | | | Factory test according to DC |
| V_d | Delectric strength | 2.5KV 50Hz 1min | | | | |

Factory commissioning :

Calculation formula: 2.5V \pm 1.25V 0V datum

1. Debugging with 0V as the reference point(acquiescence) Forward direction: $2.5 + (I/I_{PN}) * 1.25$
2. Debug with Vref as the reference point(optional) Reverse direction: $2.5 - (I/I_{PN}) * 1.25$

Instructions for use:

1. According to the connection mode of correct connection
2. The direction shown by the arrow is positive
3. With hole measurement, response time and following the speed for the best
4. Faulty wiring can lead to product damage and output uncertainty

Safe operation:

- *Please read this specification carefully before use.
- *When you need to move the product, please be sure to disconnect the power and all the connected cables.
- *If found shell, devices attached to the fixed parts, wire, or have any damaged, please immediately deal with hidden dangers.
- *If there is any doubt about the safe operation of the equipment, the equipment and the corresponding accessories should be closed immediately, and the fastest time for troubleshooting.

Proclamations:

As our products are constantly being improved and updated, we reserve the right to modify the content of this specification at any time without prior notice.

Dimensions(in mm±0.5) :

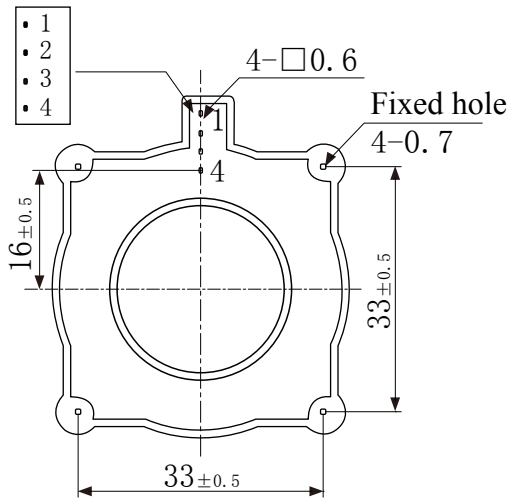

Bottom view

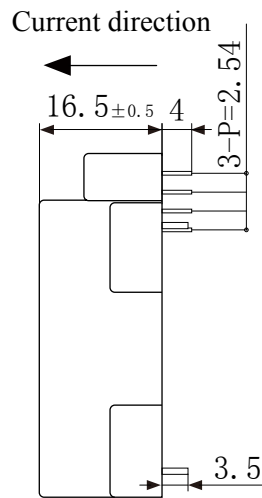

Side view

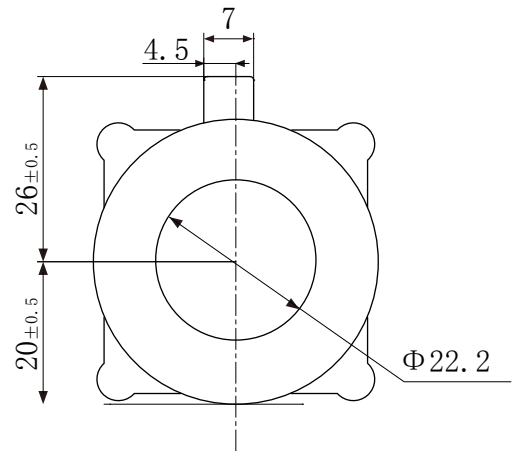

Top View

Wiring diagram (based on 0 V)

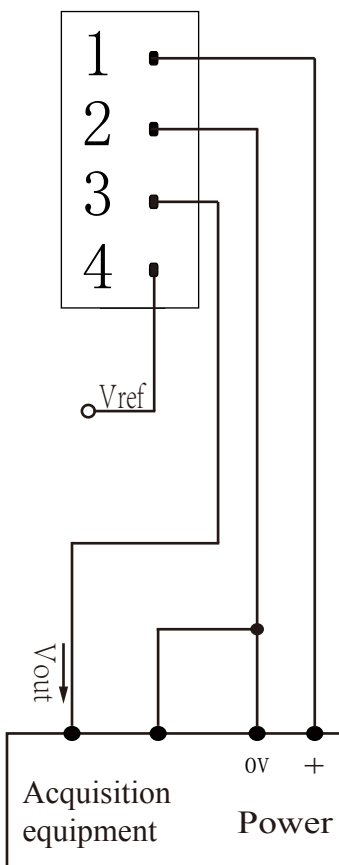

Pin definition:

- 1: +V
- 2: 0V
- 3: Vout
- 4: Vref (It can be suspended, not grounded)

※Detection:

- ① Choose the auxiliary power supply with small ripple ($\leq 10\text{mV}$)
- ② Switch on auxiliary power
- ③ The auxiliary power is connected to the sensor
- ④ The sensor detects the primary current