

HKS2015/A



Detect DC, AC and pulse current, high insulation between primary side and the vice side circuit.

Product picture: printing is for reference only, subject to the actual product

Product application

- Metallurgy
- Welding machine
- Robot
- Inverter power
- Inverter speed controller
- UPS uninterruptible power supply

Product features

- Light weight
- Low power consumption
- No insertion loss
- Fast response time
- Small size and beautiful appearance
- Sub-plate mounting installation and easy to use

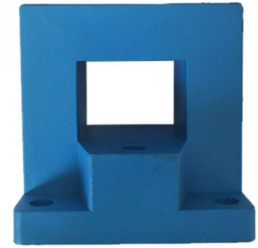

Electrical parameters: the following parameters are typical values, the actual values shall be subject to the actual measurement of the product

Rated input	±50A	±100A	±200A	±300A	±500A	±600A
Input measurement range	±50A	±100A	±200A	±300A	±500A	±600A
Rated output	2.5V±2V					
Accuracy	1% (-10~+70°C)					
Linearity	1%					
Rated supply voltage	+5V±5%					
Absolute maximum voltage	< 6V ^{(1) (2)}					
Current consumption	≤26mA					
Load impedance	≥10KΩ					
Zero offset voltage	≤±15mV					
Response time	≤10μs					
Weight	73g					
Operation temperature	-10~+70°C					
Storage temperature	-25~+70°C					
Band width	DC~25KHz					
Dielectric strength	3KV 50Hz 1min					

Calculation formula: $2.5V \pm 2V$

Forward direction: $2.5 + (I/I_{PN}) * 2$

Reverse direction: $2.5 - (I/I_{PN}) * 2$

I: Actual measured current

I_{PN} : Rated input

Factory commissioning:

Debugging is based on 0V

Terminal definition

- 1: V+
- 2: 0V
- 3: Vout
- 4: Vref

Wiring diagram

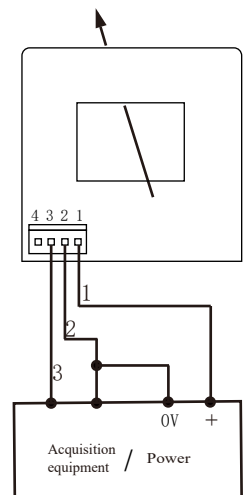

Connector :

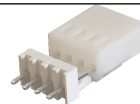

Quick plug which spacing 2.54 mm

Dimensions (in mm ±0.5) :

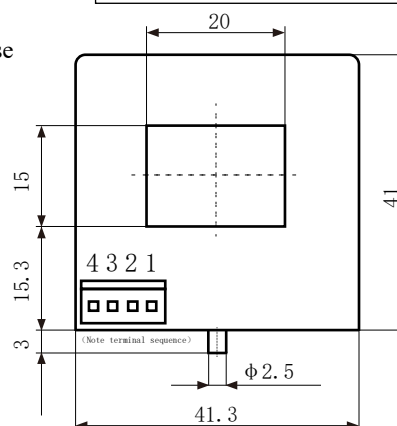

Front view

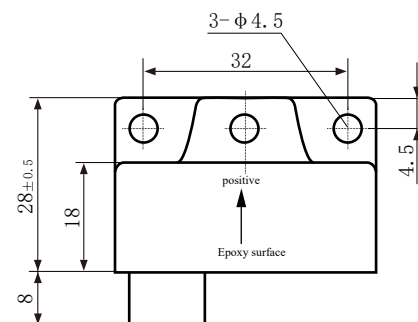

Top view

Noted:

- (1) The supply voltage exceeding the absolute maximum rating may cause permanent damage to the sensor!
- (2) Prolonged exposure to any absolute maximum rating condition may affect the reliability and service life of the sensor!
- (3) Need power protection circuit or other specifications please contact customer service!