

Hall closed loop current sensor



Model: HAB55

Closed loop, PCB welding type; Detect DC, AC and pulse current.

Technical Index:

- Flame resistance: UL94-V0
- Working temperature: $-25 \sim +70^{\circ}\text{C}$
- Storage temperature: $-25 \sim +70^{\circ}\text{C}$
- Band width: DC \sim 100KHz
- Dielectric strength: 2.5KV 50Hz 1min



Electrical parameters:

I_P	Rated input	± 50	± 100	A
I_{PM}	Input measured range	± 75	± 150	A
I_{OUT}	Rated output	± 50		mA
X	Accuracy	0.5		%
ϵ_L	Linearity	0.5		%
V_C	Supply voltage($\pm 5\%$)	$\pm 12/\pm 15$		V
I_C	Current consumption	± 12		mA+Is
R_L	Load impedance	-		Ω
I_{OE}	Zero offset TA= 25°C	$\leq \pm 0.15$		mA
T_R	Response time	≤ 1		μs
N.W	Weight	18		g

Connection diagram:

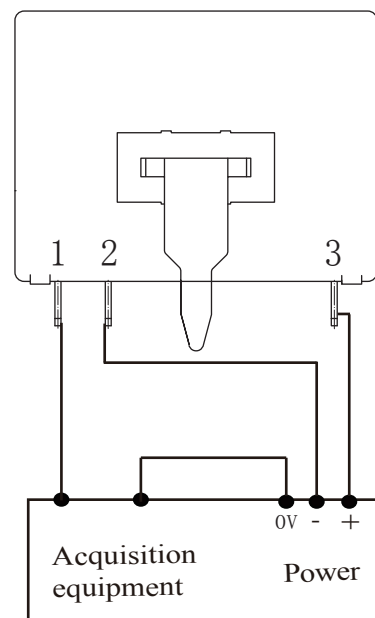

Pins definition:

- 1:M
- 2:-15V
- 3:+15V

Dimensions (in mm) :

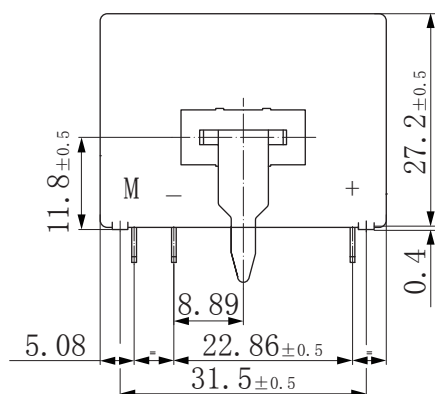

Front view

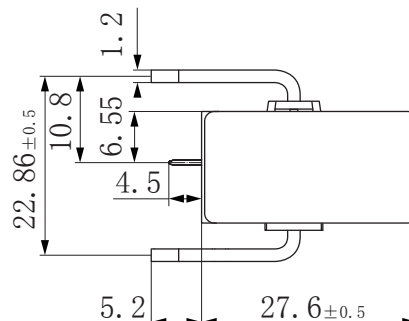

Side view

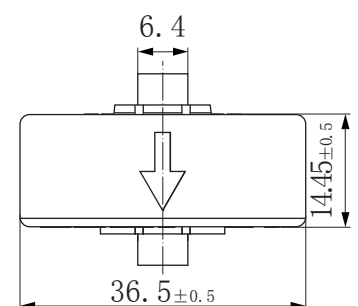

Top View