

# Hall closed loop current sensor



## Model: HA55

Closed loop, PCB welding type; Detect DC, AC and pulse current.

### Technical Index:

Flame resistance: UL94-V0

Working temperature:  $-25 \sim +70^{\circ}\text{C}$

Storage temperature:  $-25 \sim +70^{\circ}\text{C}$

Bandwidth: DC~100KHz

Dielectric strength: 2.5KV 50Hz 1min



### Electrical parameters:

$I_P$	Rated input	$\pm 50$	$\pm 100$	A
$I_{PM}$	Input measured range	$\pm 75$	$\pm 150$	A
$I_{OUT}$	Rated output	$\pm 50$		mA
X	Accuracy	0.5		%
$\epsilon_L$	Linearity	0.5		%
$V_C$	Supply voltage( $\pm 5\%$ )	$\pm 12/\pm 15$		V
$I_C$	Current consumption	$\pm 12$		mA+Is
$R_L$	Load impedance	-		$\Omega$
$I_{OE}$	Zero offset TA=25 $^{\circ}\text{C}$	$\leq \pm 0.15$		mA
$T_R$	Response time	$\leq 1$		$\mu\text{s}$
N.W	Weight	17		g

### Connection diagram:

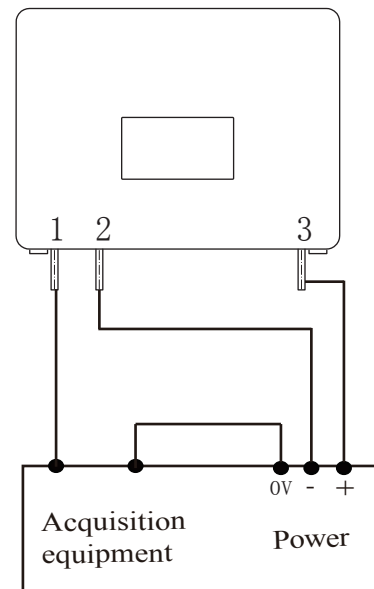

### Pins definition:

1:M

2:-15V

3:+15V

### Dimensions ( in mm ) :

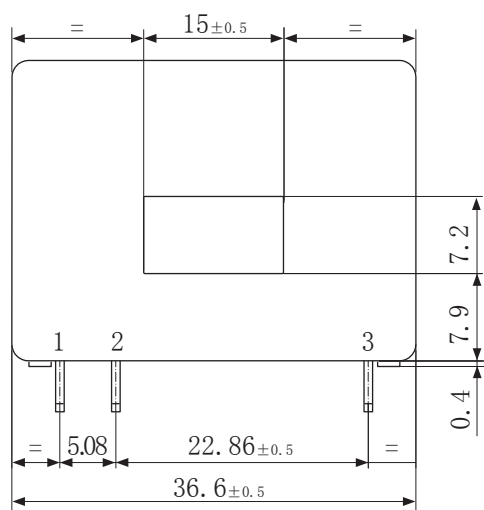

Front view

current direction

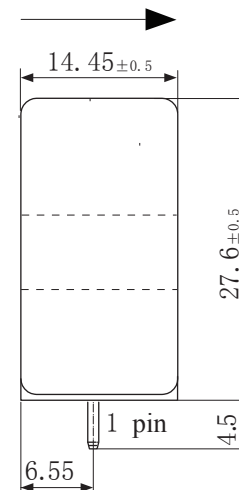

Side view