

# **CUTTING OFF SAW**

**MODEL:TV-12**



**Operation Manual**

## Table of content

1. Introduction	3
1.1 General	3
1.2 Safety regulations	3
1.3 Guarantee	4
2. Technical data	4
2.1 Main groups	4
2.2 Survey and sketch of machine	4
3. Description of machine	5
4. Installation	5
4.1 Installation and mounting	5
4.2 No-recurrent adjustment	5
4.3 Electricity	6
5. Operation	6
5.1 Selection of saw blade	6
5.2 Sawing capacity	6
5.3 Installing and replacing the saw blade	6
5.4 Saw blade	7
5.5 Clamping the material	7
5.6 Start/stop	7
6. Maintenance	8
6.1 General	8
6.2 Lubrication	8
7. Trouble shooting	8
8. Part list	9

# 1. Introduction

## 1.1. General

By means of this operator's manual you can get acquainted with your cutting off saw machine TV-300. We advise you to read the enclosed operator's manual carefully, so that you will soon be familiar with the operation and maintenance of the machine. This will minimize the times of 'downtime'.

We also ask you to pay special attention to the safety aspect that will be dealt with in chapter 1.2. Should any unexpected malfunctions occur, which can not be remedied by means of the instructions given in this operator's manual, please apply to your nearest sales outlet.

## 1.2. Safety regulations

1. Read this manual carefully, in order to get thoroughly acquainted with the operation of your machine.
2. Secure the machine to the floor.
3. The floor on which is the machine is secured, must be flat and rigid.
4. Prevent unwanted starting of the machine. See to it that the speed selector switch is in the Off positions while the machine is being connected.
5. Provide a sufficient grounding of the machine.
6. Avoid dangerous working conditions. Do not use the machine in a damp or wet environment.
7. Never work without a safety guard.
8. Wear safety goggles. Do not work with trailing pieces of clothing which could be caught by moving parts. Preferably wear ear muffers.
9. In case of danger resulting from defects, immediately contact the person in charge of the machine.
10. Support long workpieces. Your machine can easily be extended with Bewo roller conveyors.
11. Do not saw workpieces larger than those for which the machine was designed.
12. Before sawing, clamp the workpiece tightly.
13. Do not saw with excessive pressure on the saw blade. This can cause breakage of the saw blade.
14. Replace worn or damaged parts in time and do not work with blunt saw blades. Comply with the lubricating instructions and keep the machine clean.
15. Use original Bewo spare parts and accessories only.
16. Disconnect the mains while carrying out repairs or replacing parts.
17. Make sure the saw blade is not resting on the material when the machine is switched on.
18. HAVE YOUR MACHINE INSTALLED BY AN AUTHORIZED INSTALLER!!

## 1.3. Guarantee

Defects to goods delivered of which can be proved that they have occurred within 6 months of delivery as a result of an incorrectness in the design or of faulty finish or use of bad materials will be repaired by us free of charge.

Claims about externally noticeable faults are to be put in at the time of testing or inspection in our factory resp. at the latest, or in case no test or inspection takes place in our factory, within two weeks after reception of the goods. If this period is exceeded all claims relating to the faults concerned will expire.

Claims about faults which are not externally noticeable are to put in as soon as possible, however, not

later than two weeks after expiry of the period of guarantee. If this period is exceeded all claims relating to the faults concerned will expire.

The purchaser's appeal for guarantee does not relinquish his contractual obligations towards us. As long as the purchaser does not fulfil his contractual obligations towards us we deny our obligation to render guarantee.

## 2. Technical data

### 2.1. Main groups

Blade size: 300 mm

Blade speed: 2100r/min

Vice opening: 190mm

Motor power: 4 kW 50/60HZ

### 2.2 Survey and sketch of machine

Dimensions and weight of the machine

Height: 980 mm

breadth: 620 mm

Depth: 966 mm

Weight: 105kg

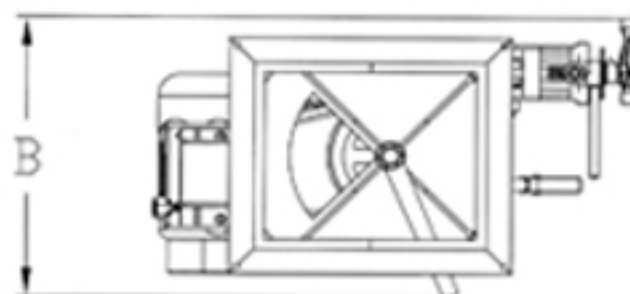
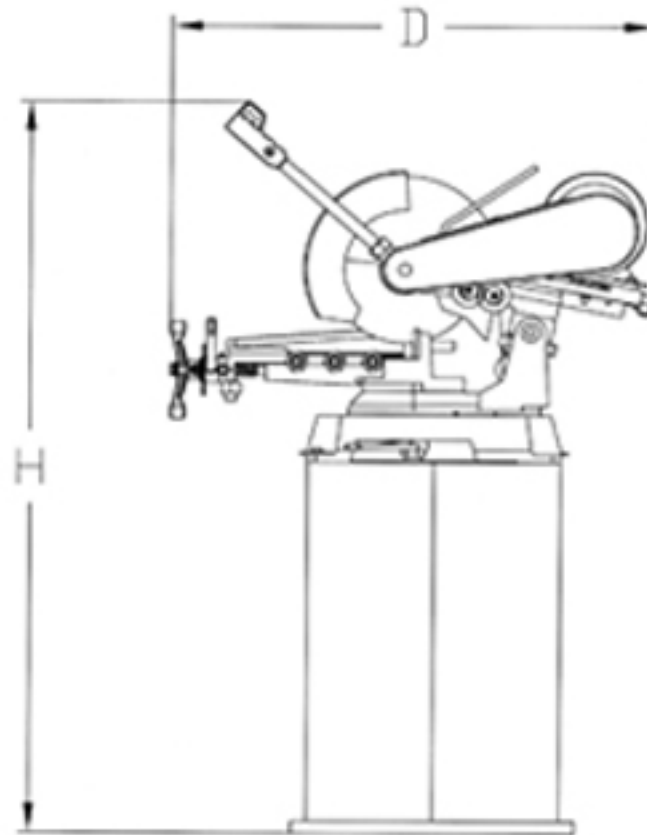

### 3. Description of machine

The machine is driven by the two belt.

The machine can mitre, slot and cut recessed comers in both directions. For this last form of operation it is of special importance that the saw unit as a whole can turn around its axis.

The machine can saw various profiles in various dimensions and cross-sections. A survey of these can be found in chapter 5.2 "Sawing capacity".

The patented protective guard opens and closes automatically. The saw blade can easily be exchanged. The machine as standard is equipped with an adapter for the saw blade (see technical data).

### 4. Installation

#### 4.1 Installation and mounting

Unpack the machine.

1. Determine where the sawing machine will be placed. In doing so take into account the feed and discharge of materials, optional built-on accessories, maintenance and repairs.
2. Place the saw unit - if necessary by means of hoisting equipment - on the machine base (cover at the rear) and attach each other.
3. Secure the machine to the floor. The necessary holes have already been made in the machine base.
4. Install the handle in the saw head and lock it (fig 4.01A).
5. Install the saw blade (see chapter 5.4).

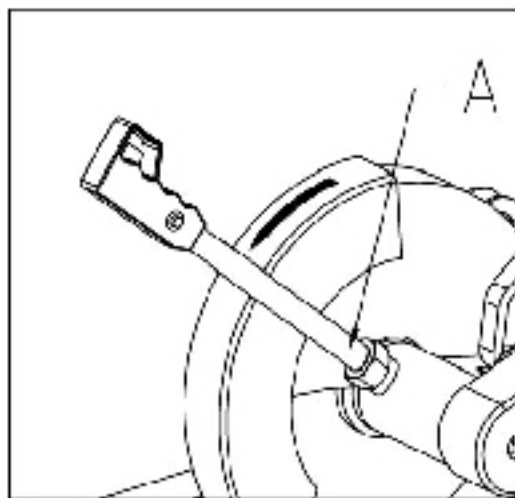

Fig 4.01

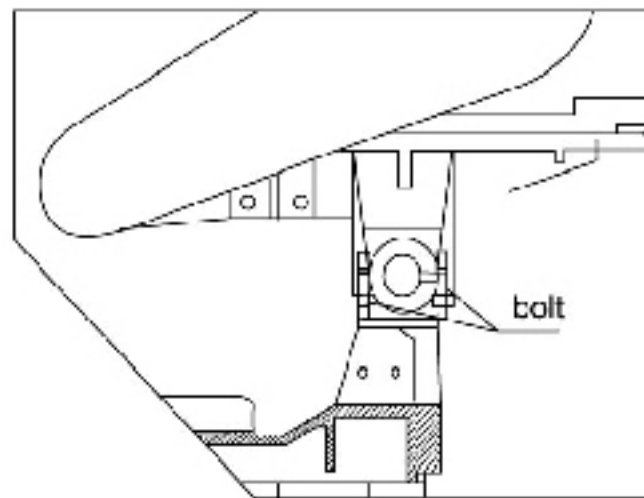

Fig 4.02

#### 4.2 Non-recurrent adjustment

This adjustment is concerning the LOWEST POSITION of the saw head. Adjust the bolt to let the saw head in the best position when lifting and falling.

### 4.3 Electricity

Have the electrical connections made by a qualified installer. Connect the machine in accordance with the electrical diagram applying to your machine.

Check whether the direction of rotation of the saw spindle corresponds to the arrow on the safety guard. If the motor rotates in the wrong direction, two phases wires must be switched.

## 5. Operation

### 5.1 Selection of the saw blade





The selection of the correct pitch depends on the material to be sawn. The selection of the correct pitch and rake angle is of great importance for the life of the sawblade.

Hint

If a short, hard jerk is felt during sawing and the saw starts jolting, do not continue. In such cases it is almost certain that at one or more places a fine chip has fused away at the flank of the saw tooth. This causes the saw to be slightly thicker at certain places. Remove the saw blade, and replace.

### 5.2 Sawing Capacity

For the maximum capacity in mm see the schedule for the profile figure/cross-cut in relationship with the mitre angle. Whit 90o we mean straight sawing.

TV-300				
90°	100	80x140	80x140	80x140
45°	90	70x100	70x100	70x100

### 5.3 Installing and replacing the saw blade

1. Set the main switch in the off position.
2. Put the saw head in the upper position.
3. Open the guards (fig. 5.03).
4. Release the socket head screw of the saw spindle (fig. 5.03B) and remove the saw flange.
5. Remove the saw blade.
6. Carefully clean the saw spindle and the saw flange.
7. Installing is done in reverse order. Pay attention to the direction of rotation of the sawblade. Make sure the saw blade is placed flush against the flange of the saw spindle. Check the setting of the sawing depth (see chapter 4.2). Do not forget to close the safety guard.

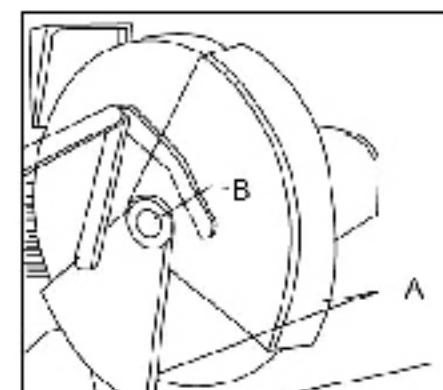

Fig.5.03

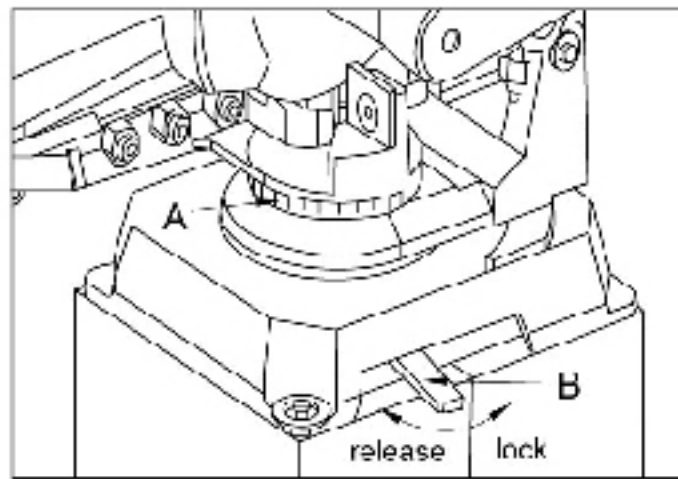

Fig.5.06

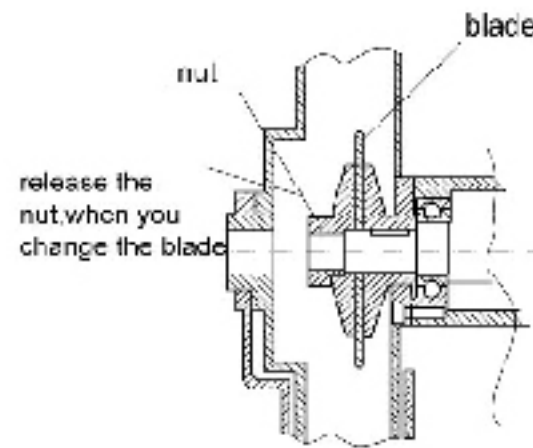

Fig.5.03B

### 5.4 Saw feed

Manual saw feed The saw feed is determined by hand. The saw is lowered onto the material by means of the handle. Press the saw blade firmly onto the material, without using unnecessary force. When the saw pressure is too high this can cause the saw to break; when the saw pressure is too low, the saw will rapidly go blunt

### 5.5 Clamping the material

It is important that the material is safely clamped in the double material vice, so that it cannot tilt over or even move during sawing. In order to work efficiently, the material must always be clamped in such a way that the contact surface of the saw and the material is as small as possible. For instance, saw flat material on its thinnest side; this will considerably shorten sawing times. When very short pieces have to be sawn, and consequently only half of the material vice will be used, in order to prevent it from pulling out of alignment, a piece of material of equal thickness must be clamped in the other half of the vice. In this way the material is clamped tightly and evenly. Application of special vice jaws is recommendable for repetitive work

Mitre-sawing Pull the clamping rod (fig. 5.06B) to the right and turn the sawing unit in the required mitre position. The position can be read out on the scale division (fig 5.06A). Then fasten the clamping rod again. Do not use unnecessary force, a slight pull will suffice. Before clamping the material, check whether the saw is running completely clear between the jaws of the material vice. Place the steel vice jaws as closely as possible to the saw.

### 5.6 Start/stop

1. Make sure the material has been fed.
2. Check the depth setting of the saw blade.
3. Check whether the vice jaws are suited for this material.
4. Adjust the material vice to the material.
5. Switch on the machine with the main switch.
6. Select the required speed.
7. Open the coolant cock on the safety guard (not in case of atomized lubrication).
8. Start machine with the switch on the pulling rod.

## 6.Maintenance

### 6.1 General

Clean the machine after it has been used. Regularly remove the chips which gather underneath the vice jaws. In doing so use a thin, flat brush and NEVER an air jet.

The belt is subject to wear. The moment the replacement of these parts is due, depends on the usage. You can order a complete set, including instructions for disassembly and assembly from your dealer. This kit is available from stock.

### 6.2 Lubrication

The rotary parts must be rinsed clean, depending on the use of the machine. Loosen the plug at the bottom of the saw head and drain the oil.

The threaded spindle, the guide rods of the material vice and the guides of the machine bed must be oiled regularly. Use BP SHF 15 for this purpose

## 7. Trouble shooting

<b>Trouble</b>	<b>Possible cause</b>	<b>Remedy</b>
Excessive bouncing or breaking of the saw.	<ol style="list-style-type: none"><li>1. Speed does not reach the request</li><li>2. Teeth blunt</li><li>3. Machine become bumping because of the broken of saw blade</li></ol>	Replace.
Motor does not trun	<ol style="list-style-type: none"><li>1. Motor incorrectly connected.</li><li>2. Relays or motor defective.</li><li>3. Selector switch is in the OFF position</li><li>4. Thermal protection of motor defective</li><li>5. Fuses blown</li><li>6. Emergency stop button depressed</li></ol>	



Item	Description	Part nr	Qty	Item	Description	Part nr	Qty
1	bolt	M8X20	4	42	Cover		1
2	washer	8	6	43	Bot	M6X16	3
3	Spring pin	6x12	1	44	Cover		1
4	Pull rod		1	45	Blade		1
5	bolt	M6X25	2	46	Cover		1
6	washer	6	3	47	Nut		1
7	ring		2	48	Key		2
8	nut	M6	1	49	Ecctricity sheatch		1
9	plate		1	50	Rotary arm		1
10	circlip	45	1	51	Ecctricity shaft		1
11	Blade guard		1	52	Shaft		1
12	Blade guard		1	53	Lock bolt	M8X8	1
13	bolt	M8X35	2	54	Lower vice		1
14	bolt	M10X70	1	55	Vice plate		1
15	nut	M10	1	56	Vice plate		6
16	motor		1	57	Bolt	M10X50	1
17	key	8x30	2	58	Spring washer	10	1
18	Block bolt	M8X12	3	59	Washer		1
19	W heel		1	60	Bolt	M6X16	3
20	Bolt	M10X25	10	61	Vice plate		1
21	Washer	10	8	62	Upper vice		1
22	Base		1	63	Adjust plate		1
23	Bolt	M6X12	2	64	Lock bot	M8X25	4
24	Washer	6	2	65	Threaded shaft		1
25	Baffle		1	66	Spring		1
26	bending plate		1	67	Ring		1
27	Belt		2	68	Oil cup	M6	1
28	Belt guard		1	69	Lock ring		1
29	Bolt	M5X10	2	70	Lock handle		1
30	Switch handle		1	71	Bearing		1
31	Lock bolt	M8X10	3	72	Bearing cover		1
32	Wheel		1	73	Handle		1
33	Handle shank		1	74	Washer		1
34	Ring		1	75	Bolt	M8X35	1
35	Nut	M14	1	76	Lock bolt	M6X10	2
36	Brace		1	77	Base		1
37	Lock bolt	M8X40	2	78	Shaft		1
38	Nut	M8	6	79	Lock handle		1
39	Bearing		2	80	Nut		1
40	Shaft		1	81	stand		1
41	key	5X20	1				

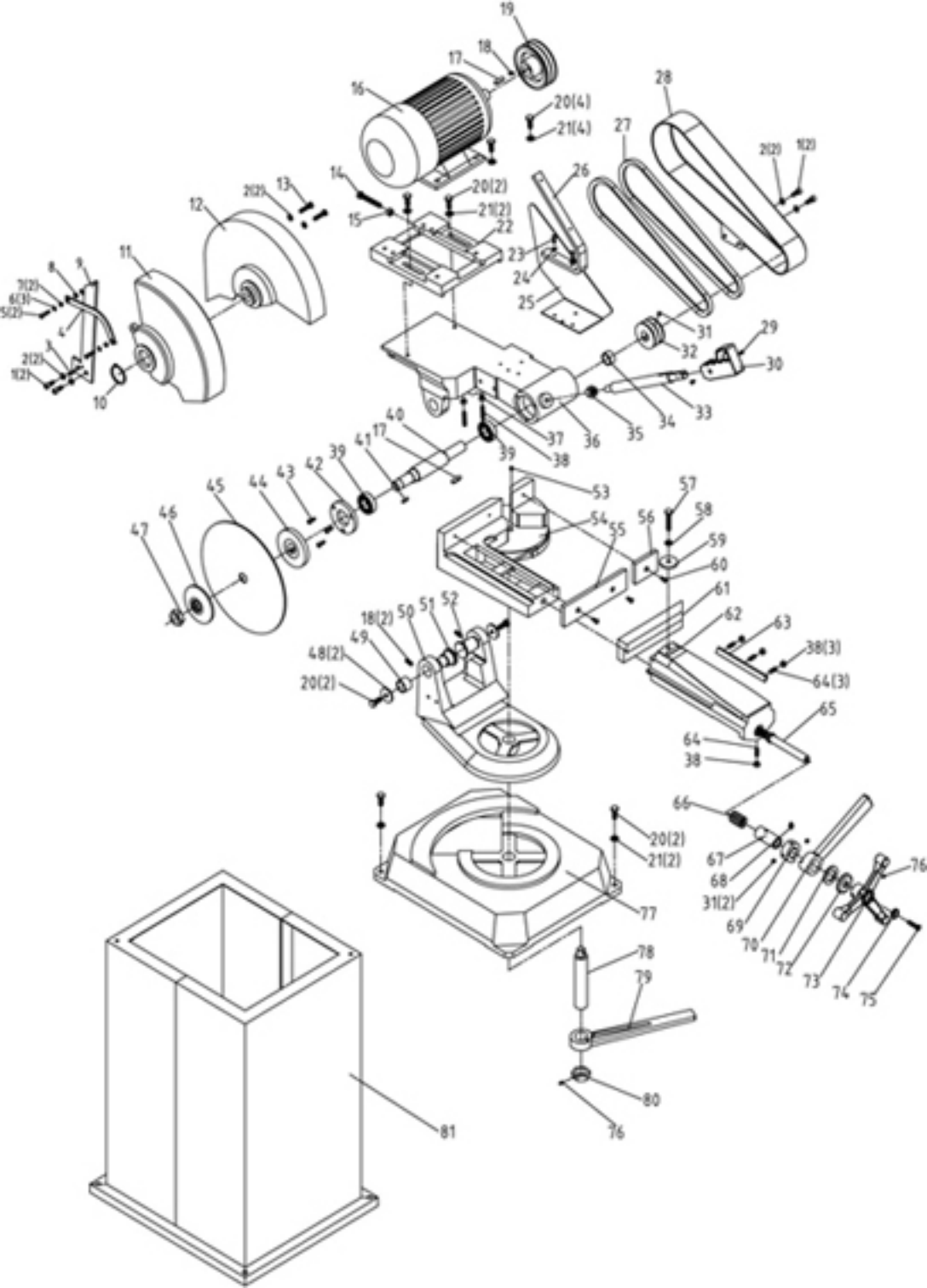

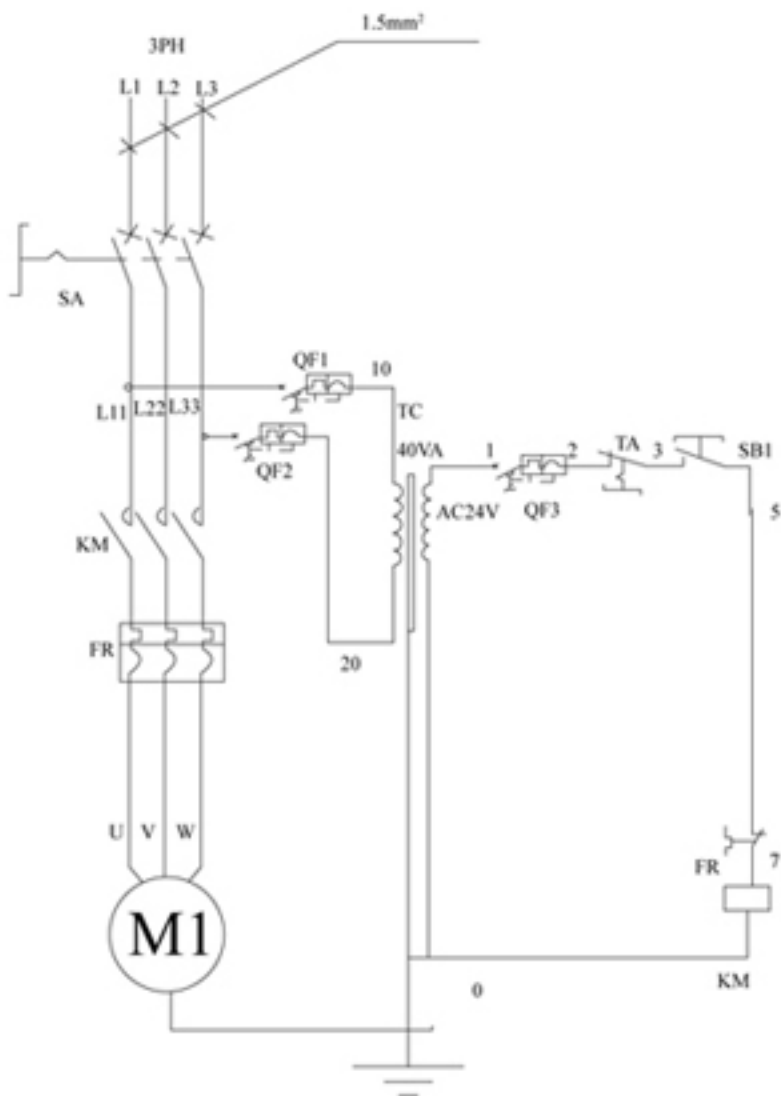

6		Cutting Off Saw TV-300	Drawn
5			Checked
4			
3			
2			
1			Circuit diagram