

LED SPORT LIGHT LUMINAIRE



Product Description

Tanlite LED sport light By using the most powerful and efficient heatsink, Special reflect lens with various beam angle options

High luminous efficiency, can work up to 50,000 hours, saving up to 80% energy, Ideal replacement to traditional metal halide lamp of 600W to 3000W.

Applications

Gymnasium, Square plaza, Shippard, Airport, High mast and Contour lighting, etc



Electric Characteristic

Specification/Model	LS-STU500W	LS-STU600W	LS-STU720W	LS-STU1000W	LS-STU1200W
LED Chips	CITIZEN COB Chips				
Input power	500W	600W	720W	1000W	1200W
Lumens output	55000LM	66000LM	79200LM	110000LM	132000LM
Efficiency	110LM/W	110LM/W	110LM/W	110LM/W	110LM/W
CRI	> 70				
Color Temperature	4000K, 4500K, 5000K, 6000K				
Input voltage	100-277Vac				
Driver brand	INVENTRONICS EUM Series				
Beam angle	15°, 23°, 38°, 45°, 60°				
Working temperature	-35~+50°C				
Junction temperature	< 75°C				
lamps efficiency	≥ 90%				
Certificate	UL	DLC UL	UL		
Equivalent	1000-1200W MH/HPS	1200W-1600W MH/HPS	1400-1800W MH/HPS	2000-2500W MH/HPS	2400-3000W MH/HPS

Ordering Information

Example: LS-STU400W-40K-N-T

Product	Power	Replacement	Color Temperature	Photocell	Furnish
LS-STU500W	500W	1000-1200W MH/HPS	40K 4000K	N not photocell Y yes photocell	T-Black W-White
LS-STU600W	600W	1200-1600W MH/HPS	45K 4500K		
LS-STU720W	720W	1400-1800W MH/HPS	50K 5000K		
LS-STU1000W	1000W	2000-2500W MH/HPS	60K 6000K		
LS-STU1200W	1200W	2400-3000W MH/HPS			

Installation

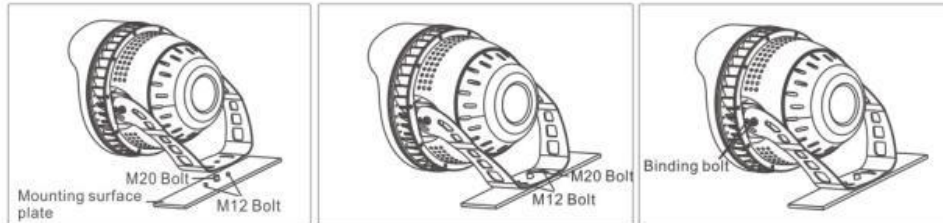

1. Fix the M20 bolt at the mounting surface plate.
2. Fix the rotatable bracket on the M20 bolt.
4. Fasten the nut, fix the light on the mounting surface.
5. Adjust the beam angle.

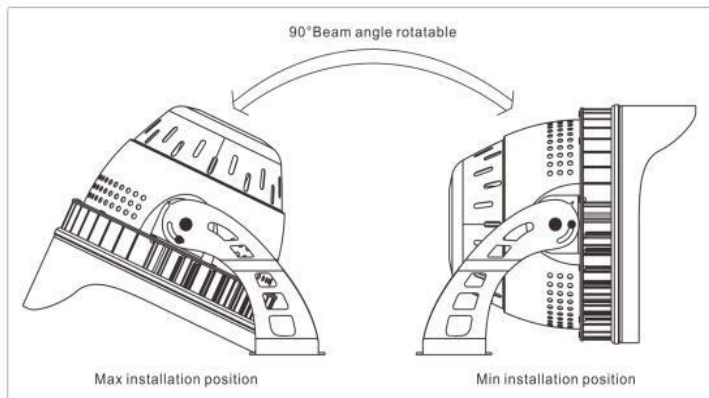

Photometrics

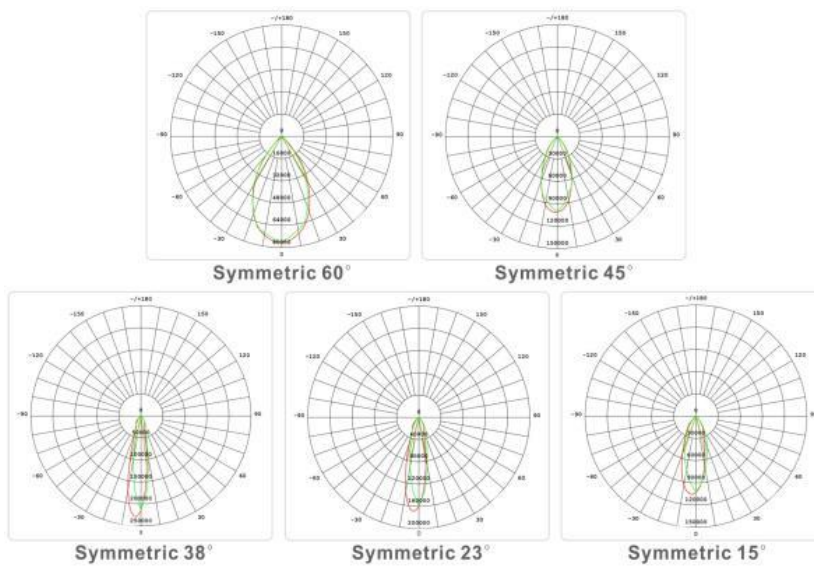

600W

Projected LED Lumen Maintenance

Operating hours	0	25000	50000
Lumen maintenance factor	1	0.91	0.8

Data references the extrapolated performance projections for the LED Sport Light platform in a 25°C ambient, based on 10,000 hours of LED testing (tested per IESNA LM- 80-08 and projected per IESNA TM-21-11).

Dimensions (mm)

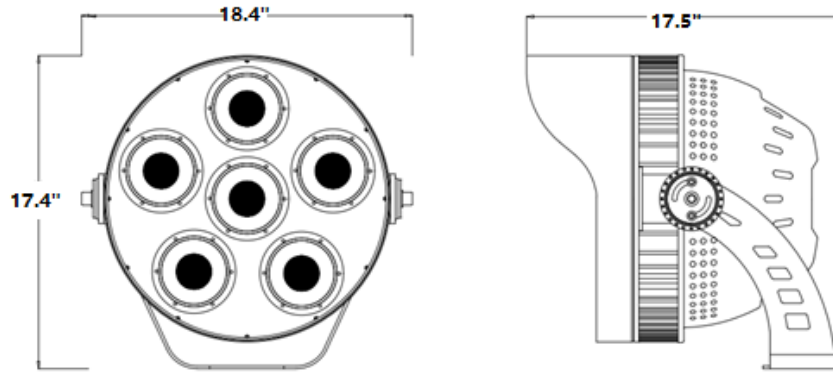

600W

After-sale Service

The product refers to electricians' knowledge. Please don't disassemble it by yourself. If any quality problem happens, please contact the factory for warranty details.

NOTE: Actual performance may differ as a result of end-user environment and application. All values are without notice.