

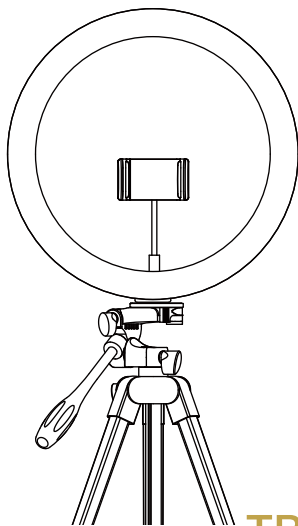

Instruction Manual



TRL-20

12" Ring Light Kit

ABOUT THIS MANUAL

Thank you for purchasing TONOR TRL-20 Ring Light Kit, This manual is intended to help you understand all about this ring light kit and how to use it. TONOR always strives for the ultimate user experience. All our knowledge and passion for technology are incorporated into building products with high performance for you. The TONOR TRL-20 is plug-and-play, easy to install, and contains all required accessories to achieve the best user experience.

Enjoy your time !

TONOR Team

CONTENTS

English	1-8
Deutsch	9-16
Français	17-24
Italiano	25-32
Español	33-40
Nederlands	41-48

ACCESSORIES

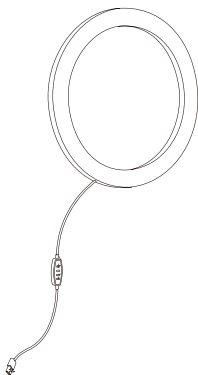

12" Ring Light with
USB Power Supply * 1

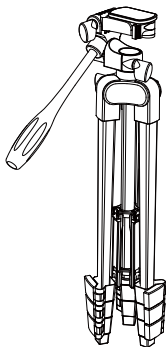

Adjustable Metal
Tripod Stand * 1

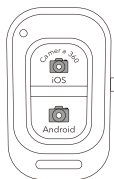

Bluetooth Remote
Shutter * 1

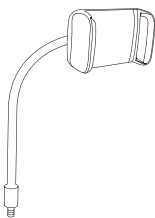

Mount Phone
Holder * 1

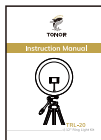

Manual * 1



After-sales Card * 1

SPECIFICATIONS

Ring Light Size:	12 inch
Color Rendering Index:	80-90
Luminous Flux:	500-800lm
Power:	10W
Input:	USB 5V-2A
LED Qty:	160
Lifespan:	>20000Hours
Tripod Stand Extendable Height:	410-1350mm/16-53inch
Color Temperature:	Cool White: 5800K-6500K Warm White: 4100K-4700K Warm Yellow: 2700K -3300K
Remote Control Battery:	CR2032, 3V

KNOWING YOUR RING LIGHT

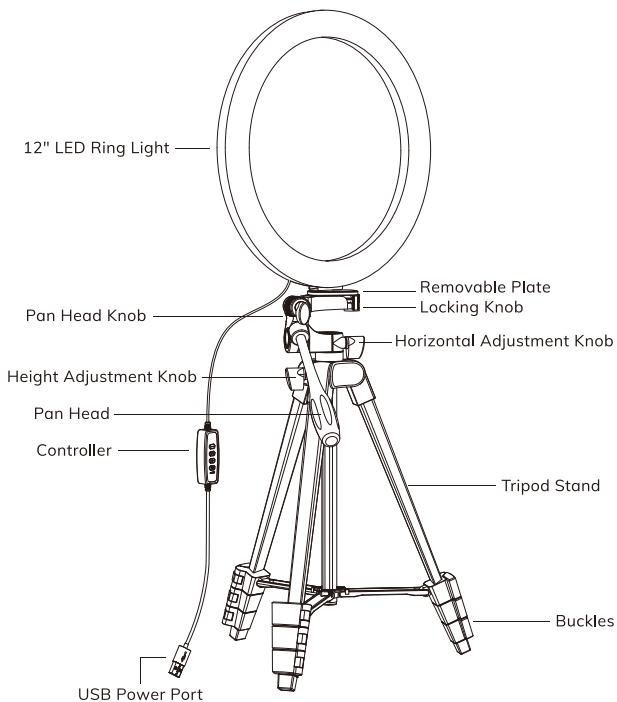

ASSEMBLY INSTRUCTION

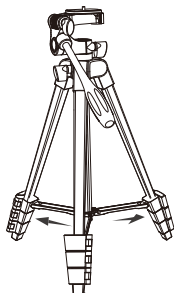

Unfold the tripod legs to the maximum width.

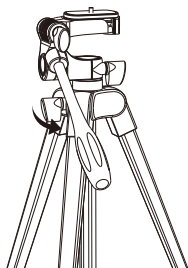

Loosen the height adjustment knob.

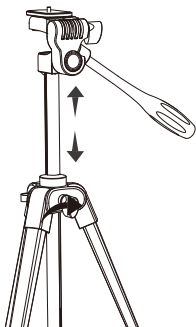

Move the tripod pole up or down to your desired height and screw the knob tight.

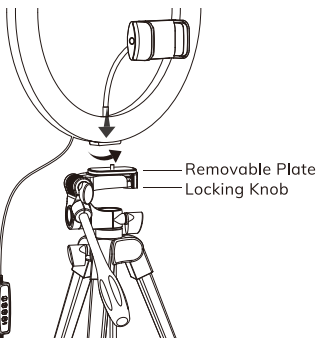

Pull the locking knob, take out the removable plate and connect it to the ring light. Pull the locking knob again and put back the removable plate with the ring light.

ASSEMBLY INSTRUCTION

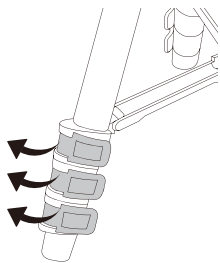

Loosen the buckles.

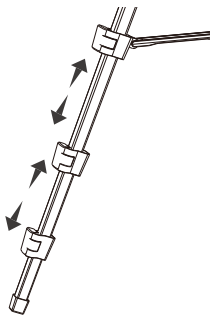

Adjust the tripod legs to your desired height.



Lock to its place.

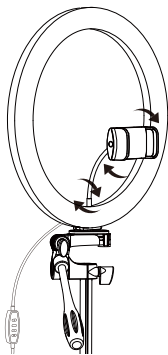

Screw the tripod mount phone holder onto the ring light and adjust to your desired angle (360 rotation).

USING YOUR STAND LIGHT

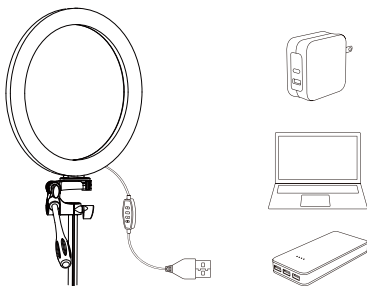

1. Power the light through the USB power port (5V — 2A) with any USB charging adapter, power bank, or active computer USB port.

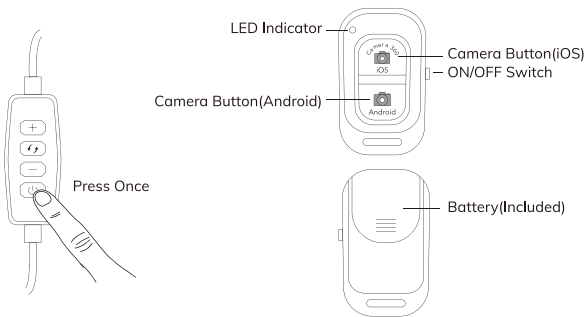

2. Adjust the brightness and lighting mode via the controller.

3. Turn on the Bluetooth function on your phone and search for TRL-20 to connect, and then press the corresponding Camera Button (iOS or Android) to take photos.

CAUTION

- For enough brightness, please ensure an input power of 5V — 2A by USB power supply.
- Switch off the device when it is not in use.
- Switch off the device before assembly and maintenance and disconnect from power supply
- Do not disassemble the device without authorization.
- Do not store the product in a high temperature environment.
- Please keep the light away from water or any other liquid to avoid electrical shock.
- Do not look directly into the light to avoid any injuries.
- This appliance is not intended for use by persons (including children) with reduced physical, sensory or mental capabilities, or lack of experience and knowledge, unless they have been given supervision or instruction concerning the use of the appliance by person responsible for their safety.
- Do not allow to be used as a toy. Close attention is necessary when used by or near children. Children should be supervised to ensure that they do not play with the product or remote shutter.
- Do not operate any light with a damaged cord or after malfunction occurs, or damaged in any manner. Discard the light, or return it to an authorized service facility for examination or repair.
- Keep away from heat and avoid direct sunlight

TROUBLESHOOTING

The following troubleshooting guide addresses the most common problems.

Problem	Possible Cause	Solution
Not enough brightness	Insufficient input power	For enough brightness, please ensure an input power of 5V— 2A by USB power supply.
The stand light does not light up	No power supply	Correctly connect to an active power port.
	The stand light is not turned on	Refer to the Using Your Stand Light section.
LED failure	LED component failed	Please contact the TONOR Support Team.
The tripod stand is not stable	Not correctly installed	Make sure the knob is tightened and the buckles are locked to its place.

ZUBEHÖR

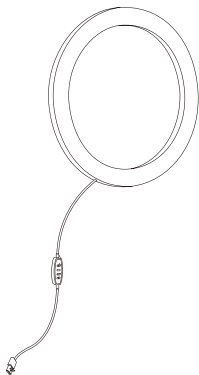

12 Zoll Ringlicht mit
USB Netzteil * 1

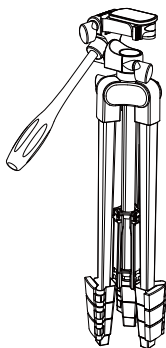

Verstellbarer
Metallstativständer * 1



Bluetooth
Fernauslöser * 1

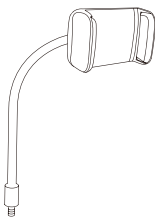

Handyhalter * 1

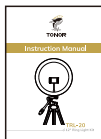

Anleitung * 1



After-Sales-Karte * 1

SPEZIFIKATIONEN

Ringlichtgröße:	12 Zoll
Farbwiedergabeindex:	80-90
Lichtstrom:	500-800lm
Leistung:	10W
Input:	USB 5V-2A
LED Menge:	160
Lebensdauer:	>20000 Hours
Stativ-Höhe (ausziehbar):	410-1350 mm/16-53 Zoll
Farbtemperatur:	Kaltes Weiß: 5800K-6500K Warmweiß: 4100K-4700K Warmes Gelb: 2700K-3300K
Batterie für die Fernbedienung:	CR2032, 3V

KENNEN SIE IHR RINGLICHT

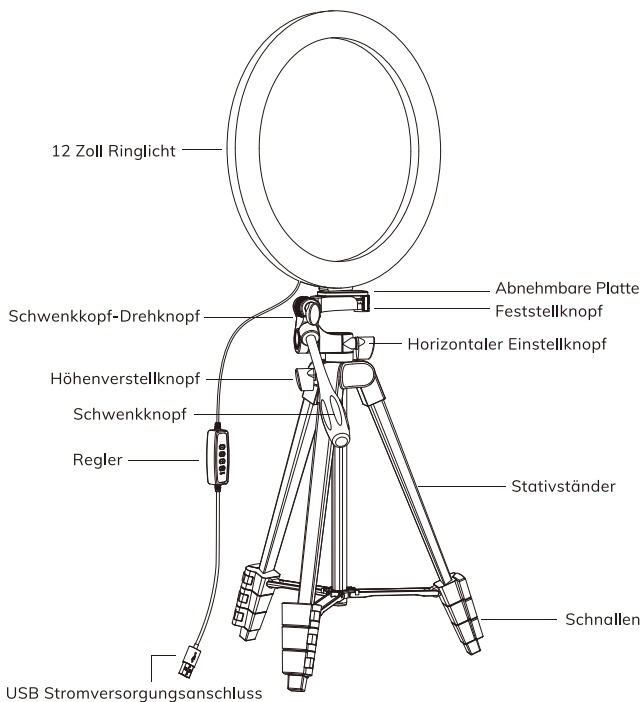

BAUANLEITUNG

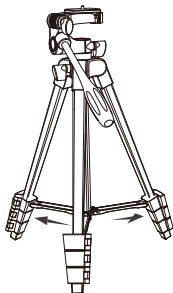

Clappen Sie die Stativbeine auf die maximale Breite aus.

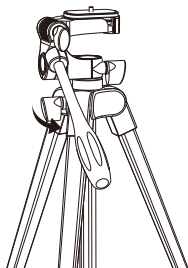

Öffnen Sie den Höhenverstellknopf.

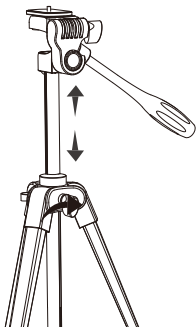

Stellen Sie die Stativstange auf die gewünschte Höhe ein und schrauben Sie den Knopf fest.

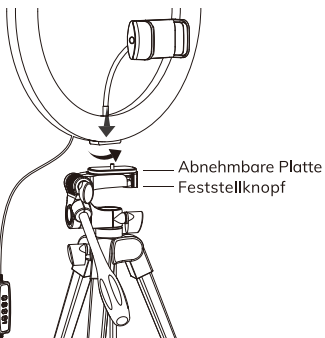

Ziehen Sie den Feststellknopf, nehmen Sie die abnehmbare Platte heraus und verbinden Sie sie mit dem Ringlicht.
Ziehen Sie den Feststellknopf erneut und setzen Sie die abnehmbare Platte mit dem Ringlicht ein.

BAUANLEITUNG

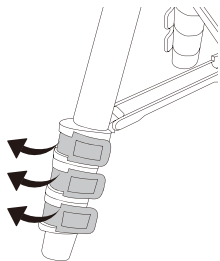

Öffnen Sie die Schnallen.

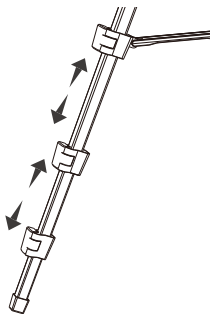

Stellen Sie die Stativbeine auf die gewünschte Höhe ein.

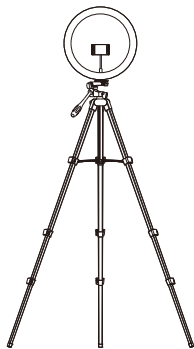

Verriegeln Sie an seinem Platz.

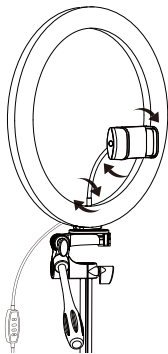

Schrauben Sie den Stativhalter auf das Ringlicht und stellen Sie ihn auf den gewünschten Winkel ein (360 Rotation).

VERWENDEN SIE IHR RINGLICHT

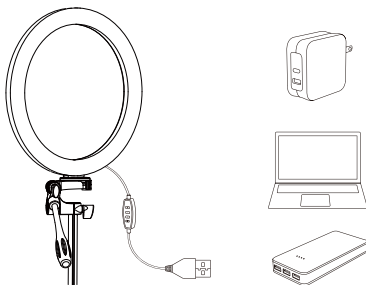

1. Unser neuester USB Steckplatz(5V-2A) bietet Ihnen mehr Optionen. Solange Sie einen USB-Ladeadapter, einer Powerbank oder einem Computers(aktiv) USB Anschluss finden, können Sie eine Verbindung zu unseren Produkten herstellen, was sehr praktisch ist.

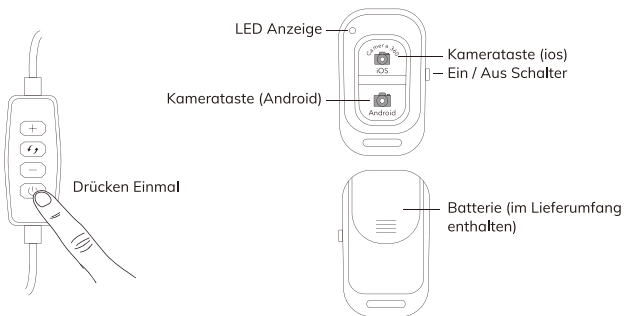

2. Stellen Sie die Helligkeit und den Beleuchtungsmodus über den Controller ein.

3. Schalten Sie die Bluetooth Ihres Handy ein und suchen Sie nach TRL-20, um eine Verbindung herzustellen. Drücken Sie dann die entsprechende Kamerataste (iOS oder Android), um Fotos aufzunehmen.

WARNUNG

- Stellen Sie für eine ausreichende Helligkeit eine Eingangsleistung von 5 V bis 2 A über das USB Netzteil sicher.
- Schalten Sie das Gerät aus, wenn es nicht verwendet wird.
- Schalten Sie das Gerät vor Montage und Wartung aus und trennen Sie es von der Stromversorgung.
- Zerlegen Sie das Gerät nicht ohne Genehmigung.
- Stellen Sie das Produkt nicht in einer Umgebung mit hohen Temperaturen.
- Bitte halten Sie das Licht von Wasser oder anderen Flüssigkeiten fern, um einen elektrischen Schlag zu vermeiden.
- Schauen Sie nicht direkt ins Licht, um Verletzungen zu vermeiden.
- Dieses Gerät ist nicht zur Verwendung durch Personen (einschließlich Kinder) mit eingeschränkten physischen, sensorischen oder geistigen Fähigkeiten oder mangelnder Erfahrung und Kenntnissen bestimmt, es sei denn, sie wurden von einer für ihre Sicherheit verantwortlichen Person beaufsichtigt oder in die Verwendung des Geräts eingewiesen.
- Lassen Sie es nicht als Spielzeug für Kinder verwenden. Wenn Kinder in der Nähe sind, muss man besondere Aufmerksamkeit sein.
- Betreiben Sie keine Licht mit einem beschädigten Kabel oder nach einer Fehlfunktion oder auf irgendeine Weise beschädigt. Entsorgen Sie das Licht oder senden Sie es zur Untersuchung oder Reparatur an eine autorisierte Serviceeinrichtung zurück.
- Von Hitze fernhalten und direktes Sonnenlicht vermeiden.

PROBLEMLÖSUNG

Die folgende Anleitung zur Fehlerbehebung behandelt die häufigsten Probleme.

Problem	Mögliche Ursache	Lösung
Nicht genug Helligkeit	Unzureichende Eingangsleistung	Stellen Sie für eine ausreichende Helligkeit eine Eingangsleistung von 5 V bis 2 A über das USB Netzteil sicher.
Das Licht leuchtet nicht auf	Keine Stromversorgung	Stellen Sie korrekte Verbindung zu einem aktiven Stromanschluss her.
	Das Licht ist nicht eingeschaltet	Siehe Abschnitt VERWENDEN SIE IHR RINGLICHT.
LED Fehler	LED Komponente ausgefallen	Bitte wenden Sie sich an das TONOR Support.
Das Stativ steht nicht stabil	Nicht korrekt aufgebaut	Achten Sie darauf, dass die Feststellschraube und die Spannverschlüsse richtig befestigt

ACCESSOIRES

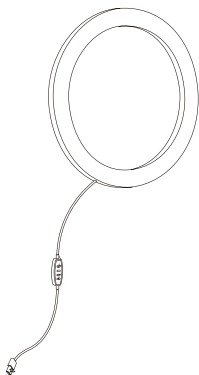

Anneau lumineux de 12"
avec alimentation USB * 1

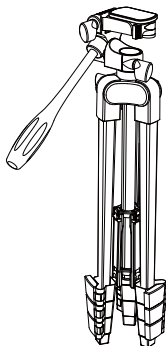

Trépied de support
en métal réglable * 1

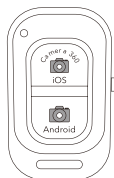

Obturbateur à distance
Bluetooth * 1

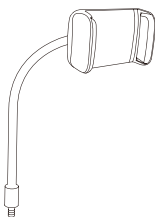

Support de fixation
de téléphone * 1

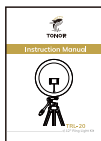

Manuel * 1



Carte après-vente * 1

CARACTÉRISTIQUES

Taille de la lumière annulaire:	12 pouces
Indice de rendu des couleurs:	80-90
Flux lumineux:	500-800lm
Puissance:	10W
Entrée	USB 5V-2A
Quantité LED:	160
Durée de vie:	>20000Heures
Hauteur extensible du trépied:	410-1350 mm/16-53 pouces
Température de couleur:	Blanc froid: 5800K-6500K Blanc chaud: 4100K-4700K Jaune chaud: 2700K-3300K
Batterie à distance:	CR2032, 3V

CONNAÎTRE VOTRE ANNEAU LUMINEUX

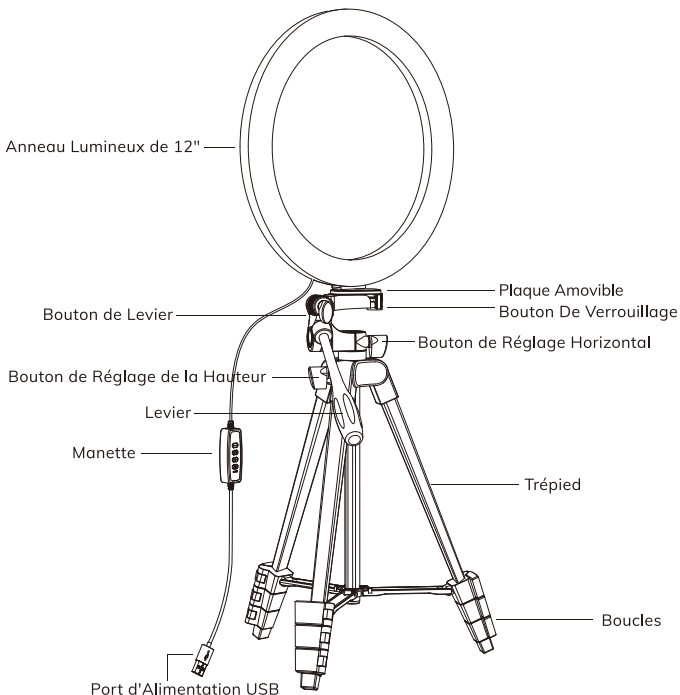

INSTRUCTIONS DE MONTAGE

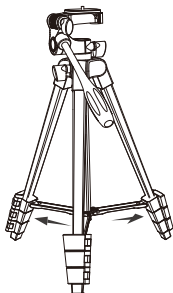

Dépliez les pieds du trépied à la largeur maximale.

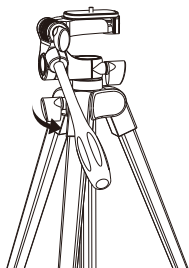

Desserrez le bouton de réglage de la hauteur.

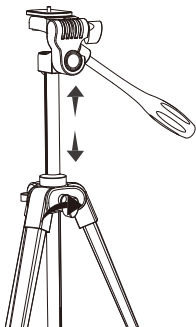

Déplacez la tige du trépied vers le haut ou vers le bas à la hauteur désirée et vissez le bouton fermement.

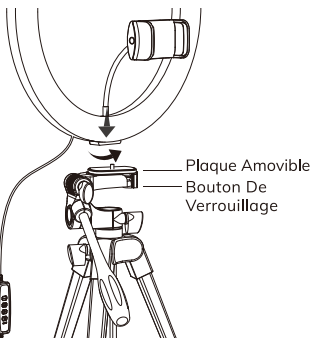

Tirez sur le bouton de verrouillage, retirez la plaque amovible et connectez-la à l'anneau lumineux.
Tirez à nouveau sur le bouton de verrouillage et remplacez la plaque amovible avec l'anneau lumineux.

INSTRUCTIONS DE MONTAGE

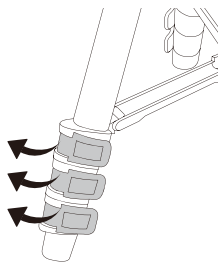

Desserrez les boucles.

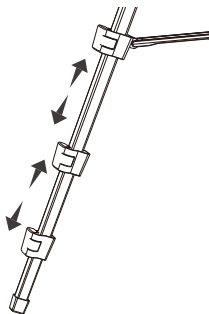

Ajustez les pieds du trépied à la hauteur désirée.

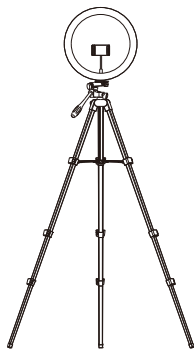

Verrouillez à sa place.

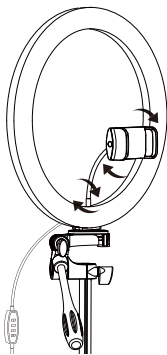

Vissez le support de téléphone du le trépied sur l'anneau lumineux et ajustez l'angle souhaité (rotation de 360).

UTILISATION DE VOTRE ANNEAU LUMINEUX

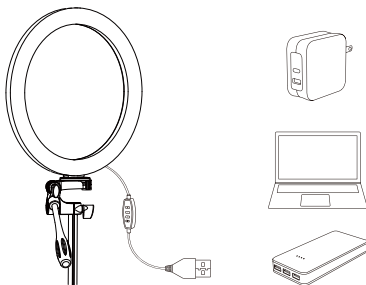

1. Alimentez la lumière via le port d'alimentation USB (5V-2A) avec n'importe quel adaptateur de charge USB, banque d'alimentation ou port USB actif de l'ordinateur.

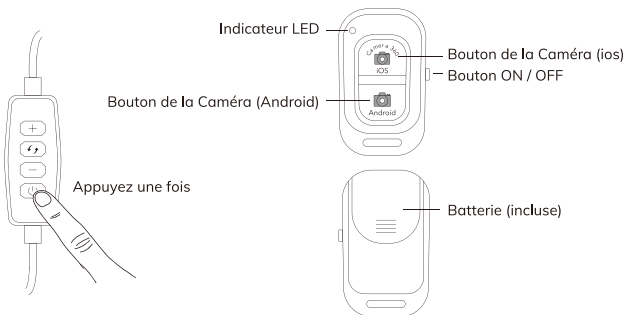

2. Réglez la luminosité et le mode d'éclairage via le contrôleur.

3. Activez la fonction Bluetooth sur votre téléphone et recherchez TRL-20 à connecter, puis appuyez sur le bouton de l'appareil photo correspondant (iOS ou Android) pour prendre des photos.

AVERTISSEMENT

- Pour une luminosité suffisante, veuillez assurer une puissance d'entrée de 5V-2A par l'alimentation USB.
- Éteignez l'appareil lorsqu'il n'est pas utilisé.
- Éteignez l'appareil avant le montage et l'entretien et débranchez-le de l'alimentation électrique.
- Ne démontez pas l'appareil sans autorisation.
- Ne stockez pas le produit dans un environnement à haute température.
- Veuillez garder le produit éloignée de l'eau ou de tout autre liquide pour éviter les chocs électriques.
- Ne regardez pas directement dans la lumière pour éviter tout risque de blessure.
- Cet appareil n'est pas destiné à être utilisé par des personnes (y compris des enfants) ayant des capacités physiques, sensorielles ou mentales réduites, ou un manque d'expérience et de connaissances, à moins qu'elles n'aient reçu une supervision ou des instructions concernant l'utilisation de l'appareil par une personne responsable de leur sécurité.
- Ne le permettez pas d'être utilisé comme un jouet. Une attention particulière est nécessaire en cas d'utilisation par ou à proximité d'enfants. Les enfants doivent être surveillés pour s'assurer qu'ils ne jouent pas avec le produit ou l'obturateur à distance.
- N'utilisez aucun éclairage si le cordon est endommagé ou après un dysfonctionnement, ou si le produit est endommagé de quelque manière que ce soit. Jetez la lampe ou renvoyez-la à un centre de service autorisé pour examen ou réparation.
- Tenir à l'écart de la chaleur et éviter la lumière directe du soleil.

DÉPANNAGE

Le guide de dépannage suivant traite les problèmes les plus courants.

Problème	Cause possible	Solution
Pas assez de luminosité	Puissance d'entrée insuffisante	Pour une luminosité suffisante, veuillez assurer une puissance d'entrée de 5V-2A par l'alimentation USB.
L'éclairage du pied ne s'allume pas	Pas d'alimentation	Connectez-vous correctement à un port d'alimentation actif.
	L'éclairage du pied n'est pas allumé	Reportez-vous à la section UTILISATION DE VOTRE ANNEAU LUMINEUX.
Panne LED	LED component failed	Veuillez contacter l'équipe d'assistance de TONOR.
Le trépied n'est pas stable	Pas correctement installé	Assurez-vous que le bouton est serré et que les boucles sont bien verrouillées à leur place.

ACCESSORI

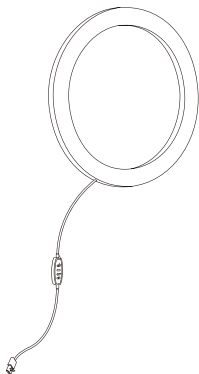

Anello luminoso da 12" con alimentazione USB * 1

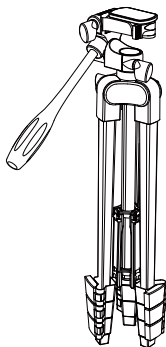

Treppiede regolabile in metallo * 1

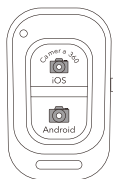

Bluetooth scatto remoto * 1

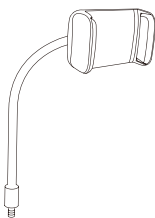

Supporto per telefono * 1

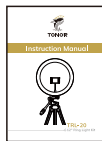

manuale d'uso * 1



tessera post-vendita * 1

SPECIFICHE

Dimensioni anello luminoso	12 pollici
Indice di resa cromatica:	80-90
Flusso luminoso:	500-800lm
Alimentazione:	10W
Input:	USB 5V-2A
Qtà LED	160
Durata:	>20000 ore
Altezza allungabile del treppiede:	410-1350mm/16-53pollici
Temperatura di colore:	Bianco freddo: 5800K-6500K Bianco caldo: 4100K-4700K Giallo caldo: 2700K-3300K
Batteria del telecomando:	CR2032, 3V

IMPARA A CONOSCERE IL TUO ANELLO LUMINOSO

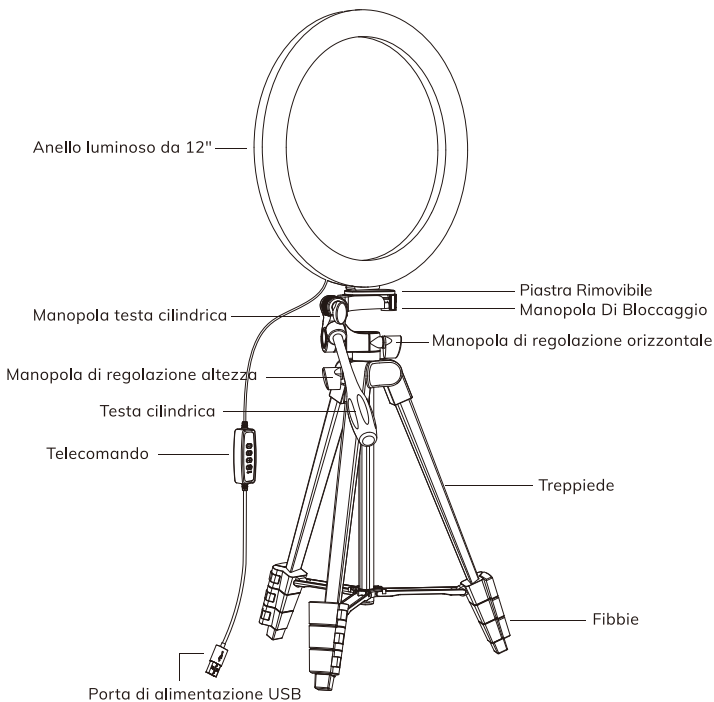

ISTRUZIONI DI ASSEMBLAGGIO

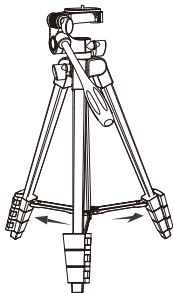

Dispiegare le gambe del treppiede alla massima larghezza.

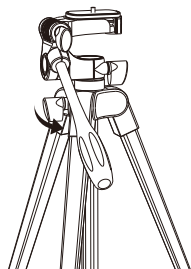

Allentare la manopola di regolazione dell'altezza.

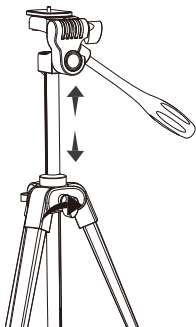

Spostare l'asta del treppiede verso l'alto o verso il basso per l'altezza desiderata e avvitare saldamente la manopola.

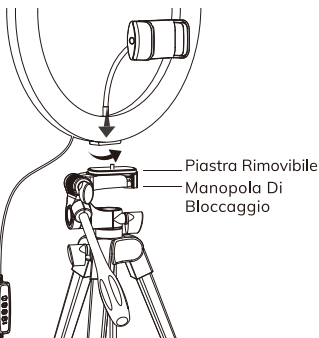

Tirare la manopola di bloccaggio, estrarre la piastra rimovibile e collegarla alla luce ad anello.

Tirare di nuovo la manopola di bloccaggio e riposizionare la piastra rimovibile con la luce ad anello.

ISTRUZIONI DI ASSEMBLAGGIO

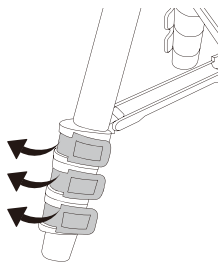

Allentare le fibbie.

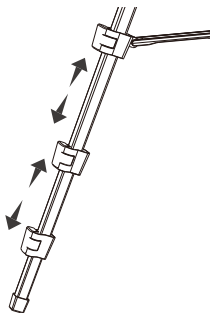

Regolare le gambe del treppiede all'altezza desiderata.

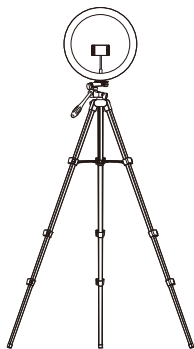

Bloccare al suo posto.

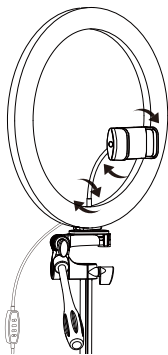

Avvitare il supporto del telefono con montaggio su treppiede sulla luce anulare e regolare l'angolo desiderato (rotazione di 360°).

USARE L'ANELLO LUMINOSO

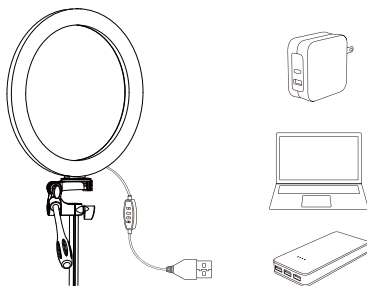

1. Accendere la luce attraverso la porta di alimentazione USB (5V-2A) con qualsiasi adattatore di ricarica USB, power bank o porta USB attiva del computer.

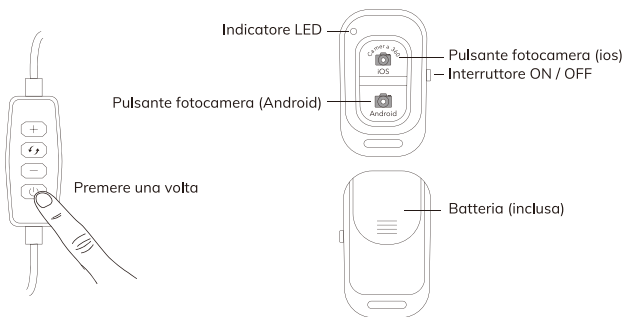

2. Regolare la luminosità e modalità di illuminazione tramite il telecomando.

3. Attivare la funzione Bluetooth sul telefono e cercare TRL-20 per la connessione, quindi premere il tasto corrispondente della fotocamera (iOS o Android) per scattare foto.

ATTENZIONE

- Per una sufficiente luminosità, si prega di assicurare una potenza di ingresso di 5V-2A dall'alimentatore USB.
- Spegnerne il dispositivo quando non è in uso.
- Spegnerne il dispositivo prima del montaggio e della manutenzione e scollegare dall'alimentazione elettrica.
- Non smontare il dispositivo senza autorizzazione.
- Non conservare il prodotto in un ambiente ad alta temperatura.
- Tenere la lampada lontana da acqua o altri liquidi per evitare scosse elettriche.
- Non guardare direttamente la luce per evitare eventuali lesioni.
- Questo apparecchio non è destinato ad essere utilizzato da persone (compresi i bambini) con capacità fisiche, sensoriali o mentali ridotte, o con mancanza di esperienza e conoscenza, a meno che non siano supervisionati o istruiti all'uso dell'apparecchio da una persona responsabile per la loro sicurezza.
- Non consentire che venga utilizzato come giocattolo. È necessaria particolare attenzione se utilizzato in presenza di bambini. I bambini devono essere sorvegliati per assicurarsi che non giochino con il prodotto o con l'interruttore di scatto remoto.
- Non utilizzare alcuna lampada con cavo danneggiato o se si verifica un guasto, o se è in alcun modo danneggiata. Smaltire la lampada, o portarla a un centro di assistenza autorizzato per un'ispezione o riparazione.
- Tenere lontano da fonti di calore e di evitare la luce solare diretta.

RISOLUZIONE DEI PROBLEMI

La seguente guida di risoluzione dei problemi affronta i problemi più comuni.

Problema	Possibile causa	Soluzione
Luminosità non sufficiente	Potenza di ingresso insufficiente	Per una sufficiente luminosità, si prega di assicurare una potenza di ingresso di 5V-2A dall'alimentatore USB.
La lampada non si accende	Nessuna alimentazione	Collegare correttamente a una porta di alimentazione attiva.
	La lampada non è accesa	Fare riferimento alla sezione USARE LA LAMPADA.
Guasto LED	Componente LED guasto	Si prega di contattare il team di supporto TONOR.
Il treppiede non è stabile	Non installato correttamente	Assicurarsi che la manopola sia serrata e che le fibbie siano bloccate al suo posto.

ACCESORIOS

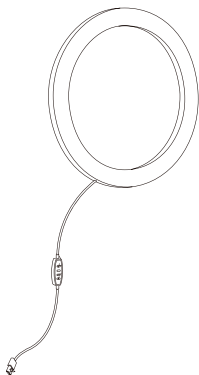

Lámpara de anillo de 12" con alimentación USB * 1

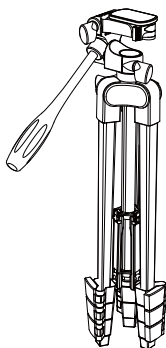

Trípode de metal ajustable * 1

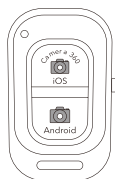

Disparador remoto Bluetooth * 1

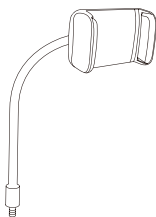

Soporte para teléfono * 1

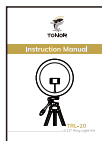

Manual * 1



Tarjeta postventa * 1

ESPECIFICACIONES

Tamaño del anillo de luz:	12 pulgadas
Índice de rendimiento del color:	80-90
Flujo luminoso:	500-800lm
Alimentación:	10W
Entrada:	USB 5V-2A
Número de LEDs:	160
Vida útil:	Más de 20.000 horas
Altura del trípode extensible:	410-1350mm/16"-53"
Temperatura del color:	Blanco frío: 5800K-6500K Blanco cálido: 4100K-4700K Amarillo cálido: 2700K-3300K
Pila del mando a distancia:	CR2032, 3V

CONOCE TU LÁMPARA DE ANILLO

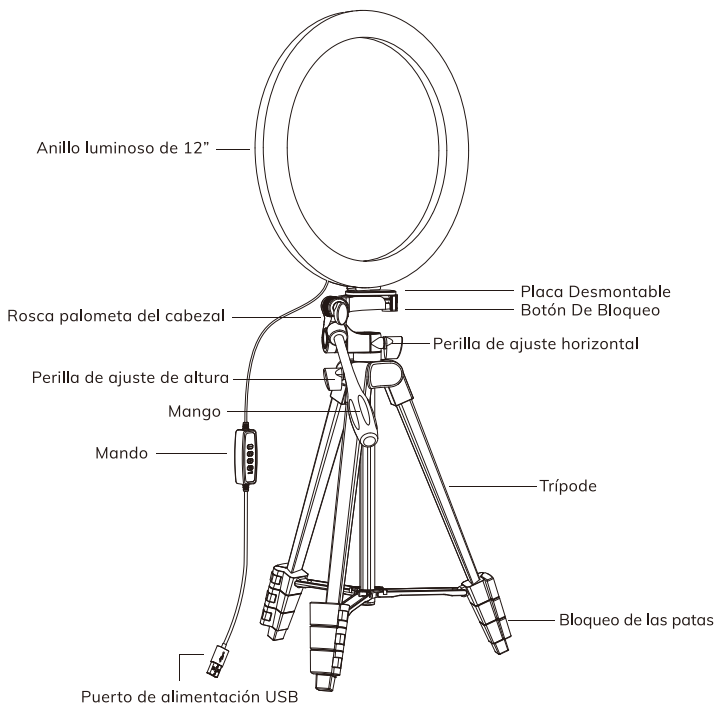

INSTRUCCIONES DE MONTAJE

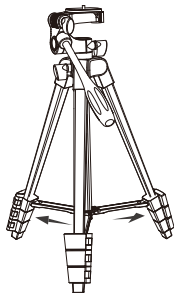

Despliegue las patas del trípode hasta alcanzar su anchura máxima.

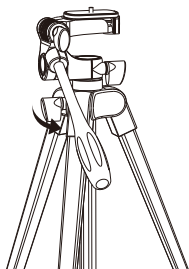

Afloje la perilla de ajuste de la altura.

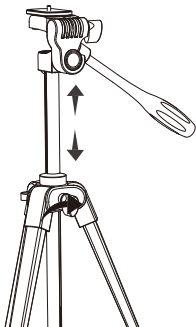

Mueva la columna arriba o abajo hasta alcanzar la altura deseada y apriete la perilla.

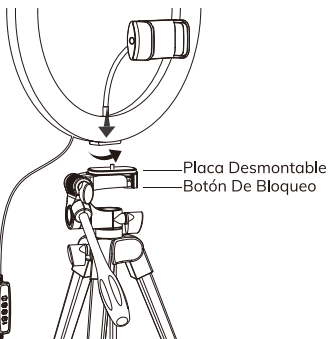

Gire el botón de bloqueo, saque la placa desmontable y conéctela al anillo de luz. Vuelva a girar el botón de bloqueo y coloque la placa desmontable con el anillo de luz.

INSTRUCCIONES DE MONTAJE

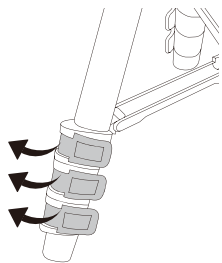

Afloje los bloqueos de las patas.

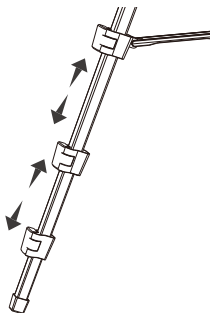

Ajuste las patas del trípode hasta la altura deseada.

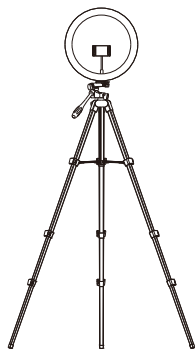

Fije los bloqueos de las patas para que no se muevan.

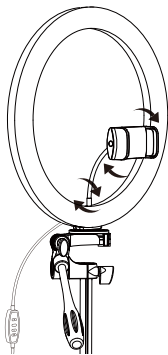

Enrosque el soporte de teléfono para el trípode en la lámpara de anillo y ajústelo según el ángulo deseado (rotación de 360°).

USO DE LA LÁMPARA DE ANILLO

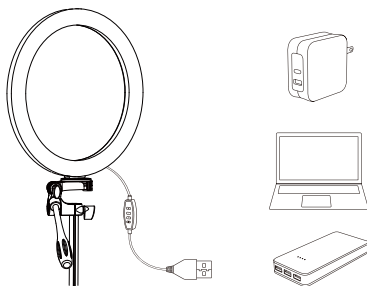

1. Alimente la lámpara usando el puerto de alimentación USB (5V-2A) con cualquier cargador USB, power bank, o puerto USB de una computadora encendida.

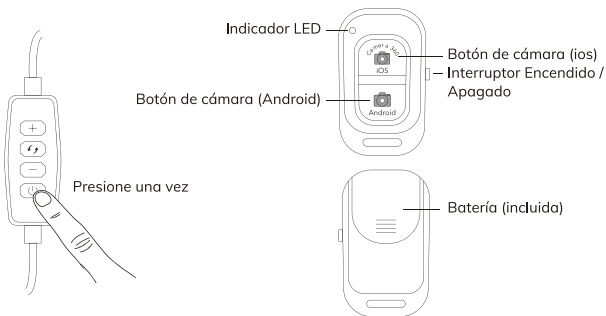

2. Ajuste el brillo y el modo de iluminación usando el mando.

3. Conecte la función Bluetooth de su teléfono y busque el dispositivo TRL-20 para conectarse a él, y luego pulse el botón de la cámara (iOS o Android) para hacer fotos.

PRECAUCIÓN

- Para que la iluminación sea la adecuada, por favor asegúrese de que la alimentación USB proporciona 5 voltios y 2A de potencia.
- Apague el dispositivo cuando no esté en uso.
- Apague el dispositivo antes de montarlo o limpiarlo, y desconéctelo de la fuente de alimentación.
- No desmonte el dispositivo sin autorización.
- No guarde el producto en un entorno caluroso.
- Mantenga la lámpara lejos del agua o de cualquier otro líquido para evitar descargas eléctricas.
- No mire a la luz directamente, podría provocar lesiones.
- Este aparato no está destinado al uso por parte de personas (incluidos niños) cuyas capacidades físicas, sensoriales o mentales estén reducidas, o carezcan de experiencia y conocimiento, a no ser que se supervisen o hayan recibido formación relativa al uso del aparato por parte de una persona encargada de su seguridad.
- No permita que se utilice como un juguete. Es necesario prestar especial atención cuando lo utilicen niños o estén cerca. Los niños deben supervisarse en todo momento para garantizar que no juegan con el producto o con el disparador a distancia.
- No utilice ninguna lámpara que presente un cable de alimentación dañado o que no funcione adecuadamente, o que esté dañada de alguna forma. Deseche la lámpara o llévela a un servicio técnico autorizado para su examen o reparación.
- Mantenga el aparato lejos del calor y de la luz solar directa.

RESOLUCIÓN DE PROBLEMAS

La siguiente guía de resolución de problemas resuelve la mayoría de los problemas más habituales.

Problema	Causa posible	Solución
No ilumina lo suficiente	Alimentación insuficiente	Para que la iluminación sea la adecuada, por favor asegúrese de que la fuente de alimentación USB proporciona 5 voltios – 2A
La lámpara no se enciende	No hay alimentación	Conecte la alimentación a una fuente adecuada.
	La lámpara no está encendida	Consulte la sección de USO DE LA LÁMPARA DE ANILLO.
Fallo del LED	Fallo del componente LED	Por favor contacte con el equipo de soporte de TONOR.
El trípode no es estable	No se ha instalado correctamente	Asegúrese de que la perilla está apretada y de que los bloqueos de las patas están cerrados.

ACCESSOIRES

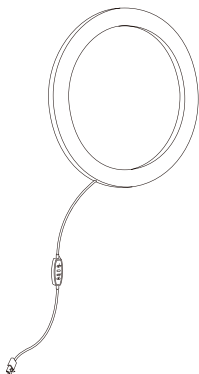

12-inch ringlicht met
USB-voeding * 1

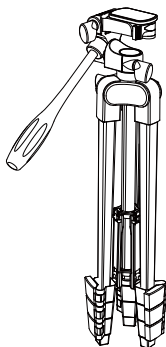

Verstelbare metalen
statief * 1

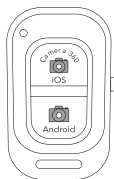

Bluetooth sluiters
afstandsbediening * 1

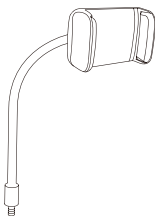

Monteerbare
telefoonhouder * 1

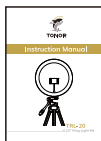

Handleiding * 1



Aftersales-kaart * 1

SPECIFICATIES

Maat ringlicht:	12 inch
Kleurweergave-index:	80-90
Lichtstroom:	500-800lm
Vermogen:	10W
Invoer:	USB 5V-2A
LED aant.:	160
Levensduur:	>20000 uur
Statief uitschuifbare hoogte:	410-1350mm/16-53 inch
Kleurtemperatuur:	Koel wit: 5800K-6500K Warm wit: 4100K-4700K Warm geel: 2700K-3300K
Batterij afstandsbediening:	CR2032, 3V

KEN JE RINGLICHT

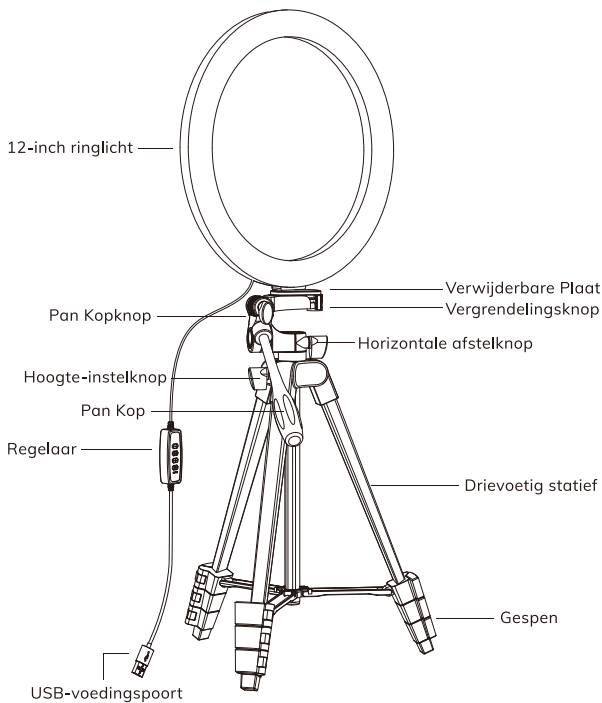

MONTAGE-INSTRUCTIES

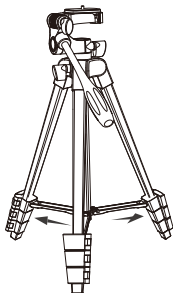

Vouw de poten van het statief uit tot de maximale breedte is bereikt.

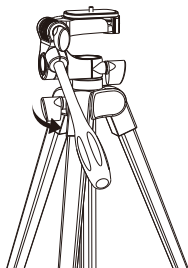

Draai de hoogte-instelknop los.

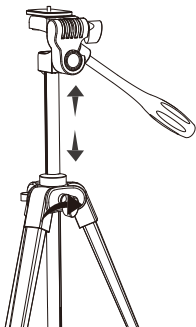

Beweeg de statiefstang omhoog of omlaag tot de gewenste hoogte en schroef de knop vast.

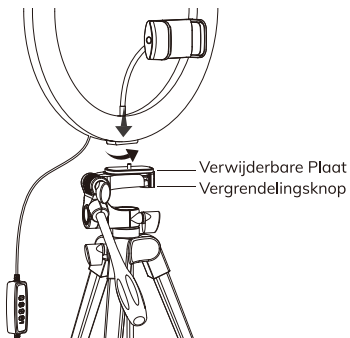

Trek aan de vergrendelingsknop, verwijder de verwijderbare plaat en sluit deze aan op de ringverlichting.
Trek opnieuw aan de vergrendelingsknop en plaats de verwijderbare plaat met het ringlicht terug.

MONTAGE-INSTRUCTIES

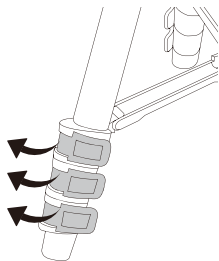

Maak de gespen los.

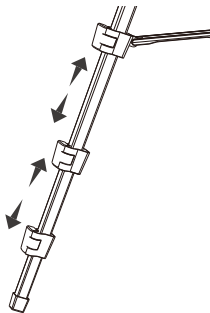

Stel de poten van het statief af op de gewenste hoogte.

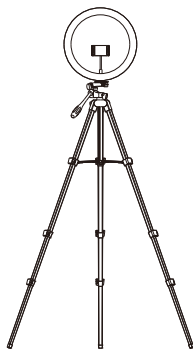

Vergrendel op zijn plaats.

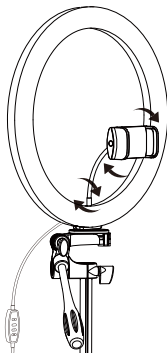

Schroef de telefoonhouder voor statiefmontage op de ringverlichting en stel deze af op de gewenste hoek (360 graden rotatie).

JOUW RINGLICHT GEBRUIKEN

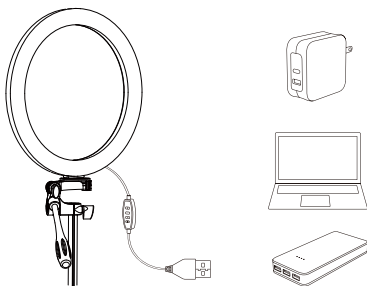

1. Voorzie de lamp van stroom via de USB-voedingspoort (5V-2A) met een USB-oplaadadapter, powerbank of actieve computer USB-poort.

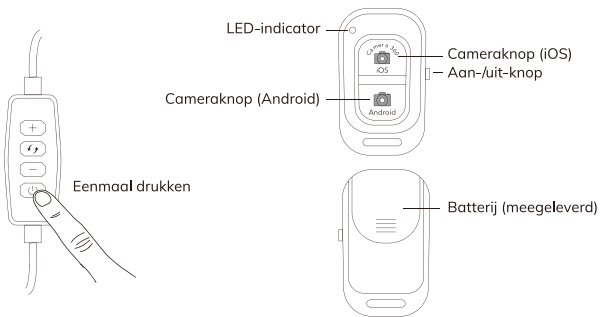

2. Pas de helderheid en verlichtingsmodus aan via de regelaar.

3. Schakel de Bluetooth-functie op je telefoon in en zoek naar TRL-20 om verbinding te maken, en druk vervolgens op de bijbehorende cameraknop (iOS of Android) om foto's te maken.

LET OP

- Zorg voor voldoende helderheid voor een ingangsvermogen van 5V-2A via de USB-voeding.
- Schakel het apparaat uit als het niet in gebruik is.
- Schakel het apparaat vóór montage en onderhoud uit en trek de stekker uit het stopcontact.
- Demonteer het apparaat niet zonder toestemming.
- Bewaar het product niet in een omgeving met hoge temperaturen.
- Houd de lamp uit de buurt van water of andere vloeistoffen om elektrische schokken te voorkomen.
- Kijk niet rechtstreeks in de lamp om verwondingen te voorkomen.
- Dit apparaat is niet bedoeld voor gebruik door personen (inclusief kinderen) met verminderd fysieke, sensorisch of mentaal vermogen, of een gebrek aan ervaring en kennis, tenzij zij onder toezicht staan of instructies hebben gekregen over het gebruik van het apparaat door een persoon die verantwoordelijk is voor hun veiligheid.
- Sta niet toe dat het als speelgoed wordt gebruikt. Let goed op bij gebruik door of in de buurt van kinderen. Kinderen moeten onder toezicht staan om ervoor te zorgen dat ze niet met het product of de externe sluiters spelen.
- Gebruik geen lamp met een beschadigd snoer of nadat er een storing is opgetreden of welke op enigerlei wijze is beschadigd. Gooi de lamp weg of breng het voor onderzoek of reparatie naar een geautoriseerd servicepunt.
- Uit de buurt houden van hitte en direct zonlicht vermijden.

PROBLEEMOPLOSSEN

De volgende gids voor probleemoplossing behandelt de meest voorkomende problemen.

Probleem	Mogelijke oorzaak	Oplossing
Niet voldoende licht	Onvoldoende ingangsvermogen	Zorg voor voldoende helderheid voor een ingangsvermogen van 5V-2A via de USB-voeding.
Het standlicht licht niet op	Geen stroomvoorziening	Correct aansluiten op een actieve voedingspoort.
	De standlamp is niet ingeschakeld	Raadpleeg het gedeelte JOUW STANDLAMP GEBRUIKEN.
LED defect	LED-onderdeel defect	Neem contact op met het TONOR Supportteam.
De driepootstandaard is niet stabiel	Niet correct geïnstalleerd	Zorg ervoor dat de knop is vastgedraaid en dat de gespen op hun plek zijn vergrendeld.

 support@tonormic.com

 www.tonormic.com