

Restoration & Moisture & Ventilation

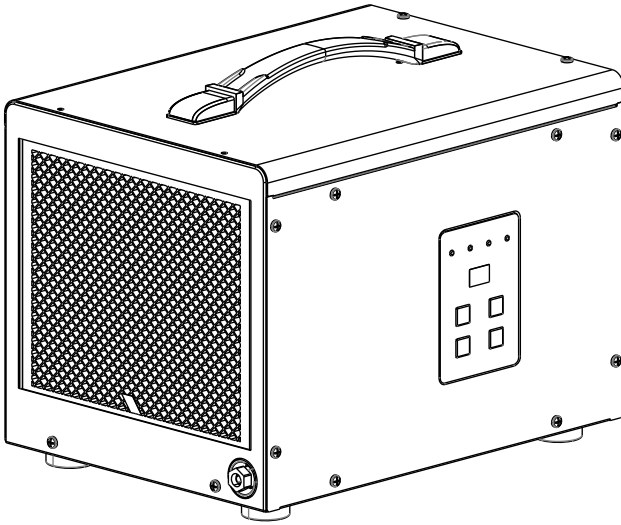

Sentinel HD35P

Installation & Operations Manual



AlorAir Solutions INC.

Add: 14752 Yorba Ct Chino CA 91710 US

Tel: 1-888-990-7469

E-mail: sales@alorair.com

Table of Contents

Warranty Registration	2
Safety Notes	2
Identification	3
Electrical Supply	3
Principle of Operation	3
Installation	4
Key Functions	4
Indicator Lights	6
Remote Control	7
Diagram	8
Maintenance	9
Dehumidifier Storage	9
Troubleshooting	10
Water Pump Maintenance and Application	11
Spare Parts	14
Warranty Information	15

Warranty Registration

Congratulations on purchasing a new Sentinel Dehumidifier. Your new dehumidifier comes with an extensive warranty plan. To register, simply fill out and return the warranty form provided in the dehumidifier box.

Be sure to note your dehumidifier serial number as you will need it for registration.

Safety Notes

- The Sentinel Series Dehumidifier must always be connected using a grounded electrical connection (as required for all electrical appliances). If non-grounded wiring is used, all liability reverts to owner and the warranty is voided.
- Sentinel Dehumidifiers should only be maintained and repaired by a qualified technician.
- Sentinel Dehumidifiers are only intended for operation when oriented with the unit sitting on its feet and level. Operating the unit in any other orientation could allow water to flood electrical components.
- Always unplug dehumidifier before moving.
- If there is a chance that water flooded the dehumidifier, it should be opened and allowed to dry thoroughly before reconnecting to electrical power and restarting.
- To ensure proper operation, neither the inlet nor discharge should be positioned against a wall. The inlet requires a minimum of 6' clearance and the discharge requires a minimum of 6' clearance.
- For better use of the dehumidifier, both air inlet and air outlet should be facing the open area of the space.
- Do not insert your fingers or any object into the inlet or discharge.
- All work on the dehumidifier should be done with the unit "off" and unplugged.
- Do not use water to clean the exterior of the machine. To clean unit, unplug from power, then use a damp cloth to wipe exterior.
- Do not stand on the machine or use it as a device to hang clothes.

Identification

For future reference, write down the model, serial number, and date of purchase for your dehumidifier. This is extremely helpful if you need to seek assistance in the future. The data label on the side of your unit has the key characteristics of your specific machine.

Model Number: Sentinel HD35P

Serial Number: _____ **Date of Purchase:** _____

For additional questions concerning your dehumidifier, the following options are available:

- Contact your installing contractor
- E-mail: sales@alorair.com

Electrical Supply

Power Supply: 115 V, 60 Hz AC, Single Phase

Outlet Requirement: 3-Prong, GFCI

Circuit Protector: 15 Amp

WARNING: 240 Volts AC may cause serious injury from electric shock.

To reduce risk of injury:

1. Disconnect electrical power before servicing .
2. Only plug unit into grounded electrical circuit .
3. Do not use an extension cord.
4. Do not use a plug adapter.

Principle of Operation

The Sentinel Series Dehumidifier utilizes its integral humidistat to monitor the conditioned space. When the relative humidity goes above the selected set point, the dehumidifier will energize. Air is drawn across an evaporator coil, which is cooler than the dew point of air. This means moisture will condense out of the air. The air is then reheated through the condenser coil and distributed back into the room.

Installation

The area to be controlled should be sealed with a vapor barrier. If unit is installed in a crawlspace, all vents should be sealed.

WARNING: Do not install your dehumidifier in a corrosive environment. Some liquid vapor barriers dry via “solvent evaporation”. Always make sure that barrier is completely dry and area is thoroughly ventilated before installing dehumidifier.

Step #1: Place dehumidifier on a level surface.

Do not place directly on vapor barrier. For example, use blocks, or pavers to create a level surface. If the unit is handled in such a manner that the compressor did not remain in the upright position, you will need to place it on a level surface, then wait a minimum of 2 hours before turning “on”.

Step #2: Set Up Drain Line.

The included drain line attaches to unit via a compression type fitting on the discharge end of the unit. To attach drain line, remove the compression nut and slide it over the end of the hose to be attached to unit. Slide compression nut side of hose over the insert on the compression fitting completely. Tighten compression nut.

Step #3: Plug unit into 15 amp grounded circuit.

Key Functions

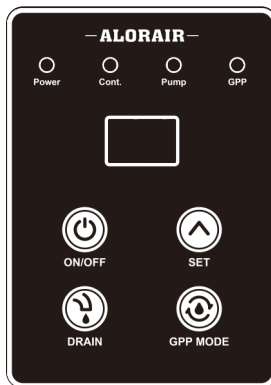

1. The “ON / OFF” Button

Press this button to turn ON/OFF the dehumidifier.

When the dehumidifier is turned off, there would be a 120 seconds delay on the fan. Do not unplug the unit until the fan is off.

2. “SET” Button

This button is used to change the humidity setpoint from 25% to 80%. The dehumidifier may also be set at “CO” or Continuous Operation mode to run the dehumidifier continuously. The setpoint has 5% increments of each press.

The dehumidifier will automatically turn on/off when the Relative Humidity Percentage(%) is 3% - 5% higher/lower than the setpoint.

3. “Drain” Button

Hold this button down for at least 3 seconds to switch the drain system to use. Either pump drain system or gravity drain system.

Water Pump Drainage Mode

If the “Pump” light is turned ON, it indicates that the pump drain system is in use.

The “Drain” button can be pressed once to force the water pump to remove the collected moisture from the water tray for 14 seconds. This button is not valid when the pump is draining.

If the water pump float switch detected a high level of water in the tray, the pump will automatically run and drain the collected moisture for 14 seconds. If a high level of water is still detected, after the pump runs for 14 seconds, the screen will display an “E4” error code, and the entire machine will be turned off.

Gravity Drainage Mode

If the “Pump” light is turned OFF, it indicates that the gravity drain system is in use.

The Water Tray Plug should be removed from the dehumidifier to properly use this drain system. This allows the dehumidifier to continuously drain the moisture collected.

If a high level of water is detected by the float switch for 14 seconds, the screen will display an “E4” error code and the dehumidifier will STOP from running to avoid a water leak.

Note: When moving the machine from one location to another, wait at least 10 minutes after turning off. This will allow the moisture in the coil to drip down in the water tray and you may tilt the dehumidifier in the direction of the drain hole to remove the collected moisture or water, completely.

4. “GPP” button

This button is used to change the humidity reading from RH% to GPP (Grains per pound).

GPP is the unit used to measure the weight of moisture in the air. The number of grains per pound of dry air expresses the specific humidity of the air. The GPP setpoint can be set at 25 to 200.

Relative humidity (RH) refers to the moisture content of the atmosphere, expressed as a percentage of the amount of moisture that can be retained by the atmosphere at a given temperature and pressure with condensation.

5. “SET +Drain” key

if you press the combination button “SET +Drain” for 3 seconds, the temperature of the room will be displayed in Celsius.

6. “SET +GPP” key

“SET + GPP” key combination press for 3 seconds to display the temperature of the coil in Celsius.

Indicator Lights

1. Humidity Display Screen

- The display screen has two functions:
 1. When the unit is powered on, it shows the humidity of the space.
 2. While setting the desired humidity level, the screen will show the set humidity. After a brief delay, the display will revert to current humidity level.

2. Power Indicator Light

- This indicator indicates that the device is powered on and ready for operation. Always ensure that the device is in the "off" state before performing any service. After power is powered on, the buzzer will beep twice, and the machine will enter the standby state, and this light is not on. The light is steady on after the machine is turned on and off after the machine is turned off. In other states, the indicator blinks (for example, error codes H1 and LO, humidity reaches slowly blinks, defrosting quickly blinks). (Note: This light is off when error code E4 stops.)

3. Continuous Mode

- When this light illuminates green, it indicates that the dehumidifier is set to continuous operation mode.

4. Pump Pattern Light

- Water pump mode, this light is on; Gravity drain mode, this light is off. The default mode of the device is gravity drainage.

5. GPP Mode Light

- When the compressor is in GPP mode, the light is on. In normal mode, this light is off.

Remote Control Instructions

Sentinel Dehumidifiers can be controlled using an optional remote accessory. The Sentinel Remote Control connects to your Sentinel Series Dehumidifier via a 25' CAT 5 cable. The remote control contains an integrated sensor which gives you multiple options for remotely controlling your unit, in addition to monitoring the conditions surrounding the dehumidifier.

One application for the remote control is to install the dehumidifier in one room with the conditioned air ducted into a second room that contains the remote. For example, the dehumidifier could be installed in a laundry room and ducted into a living room. The remote would then be mounted in the living room so the remote sensor can control the humidity and provide easy controls for the user.

Another useful application for the remote control is if the dehumidifier is in area that's difficult to access on a regular basis. For instance, if your dehumidifier is installed in your crawl space, the remote could be mounted in your living space or garage. This provides you with an easy way to monitor the dehumidifier.

1. On/Off (Power) Button \odot

Press the on/off button and the machine will start running (one beep). Press the button again to turn the machine off.

2. Up Button \blacktriangle / Down Button \blacktriangledown

Use the Up and Down arrow buttons to adjust the humidity level.

3. Mode M

Use the Mode button to switch between dehumidification and a ducted application.

- The \odot symbol on the display board indicates the sensor on the remote control is being utilized.
- The \blacktriangledown symbol on the display board indicates the sensor on the dehumidifier is being utilized.

4. Temperature T

Press the temperature button to display the current temperature on the screen. Press the button again to turn off the display.

5. Continuous C

Press this button to switch the unit into continuous mode. **Cont.** will appear on the display to indicate continuous mode.

6. Drain Pump P

Use this button if the unit will not be in use for an extended period of time. Pressing the drain pump button will remove water from the pump reservoir, so the unit can be safely moved or stored. THIS FUNCTION IS ONLY AVAILABLE ON THE Sentinel HDi65, Sentinel HDi90, Sentinel HD35P model.

NOTE: Symbols indicated above will only appear when the dehumidifier is powered on.

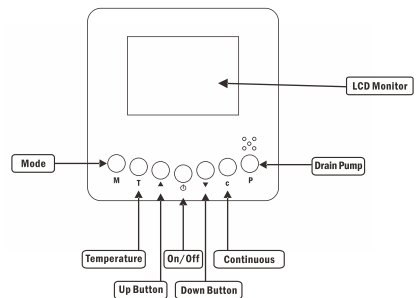

Sentinel HD35P Diagram

Front View

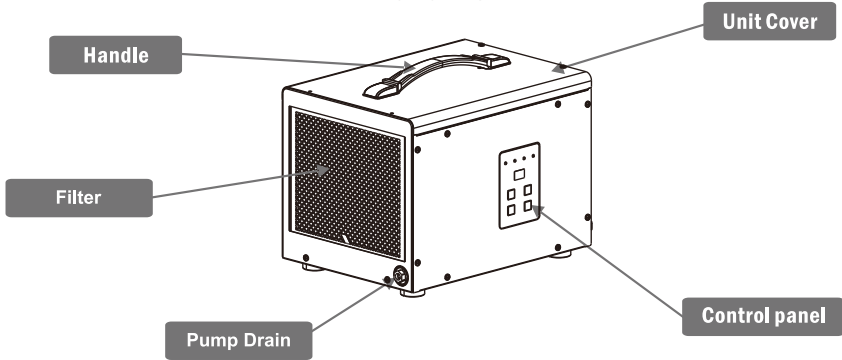

Back View

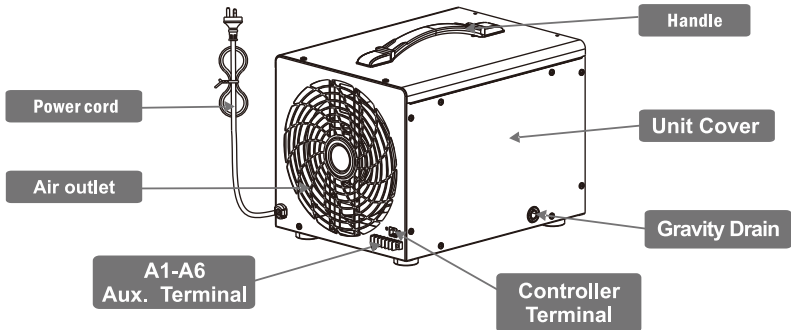

Maintenance

WARNING: Always unplug the unit before doing any maintenance.

Cleaning the machine body

Use a soft damp cloth to clean exterior of unit. Do not use any soap or solvents.

Coil Maintenance

- Once per year, clean the coils with an approved coil cleaner.
- Coil cleaner should be a self rinsing, foaming cleaner such as WEB® Coil Cleaner.

Dehumidifier Storage

If the unit will be stored for an extended period of time, complete the following steps:

1. Turn off the unit and allow to dry.
2. Wrap and secure the power cord.
3. Cover the filter mesh.
4. Store in a clean, dry space.

Troubleshooting

Symptom	Cause	Solution
Machine Won't Run	Power Supply	Verify that there is power to the outlet and that the plug is properly installed in outlet
	Room Temperature Over 110°F (Display HI) or Below 33.8°F (Display LO)	The unit is outside the operating temperature range. Modify the room conditions so the temperature is between 33.8°F-110°F and operation will commence. (The set humidity must be lower than the ambient humidity.)
Low Air Flow	Air Filter is Clogged	Clean the filter mesh according to instructions listed in manual.
	Air Inlet or Outlet is Blocked.	Clear the blockage from inlet or outlet.
Loud Noise	Machine Is Not Level	Move the dehumidifier to flat, firm ground.
	Filter Mesh is Blocked	Clean the filter mesh according to instructions listed in manual.
Trouble Code E:1	E1=Humidity Sensor Issues	Check to ensure that wire is connected at both ends. If no issues are visible, the sensor may be faulty.
Trouble Code E: 4	Pump has failed	Verify that the pump is working. If so, unplug the unit for two minutes, then restart.
Trouble Code: HI or LO	Room Temperature Over 110°F or Below 33.8°F(Display LO)	The unit is outside the operating temperature range. Modify the room conditions so the temperature is between 33.8°F-110°F and operation will commence. If room conditions are within temperature range, replace defective sensor.
Trouble Code E: 5	Refrigerant Leak	Contact Your Installer for Assistance.

Pump Alarm- Trouble Code E4

If a pump alarm is shown on the display, complete the following steps:

1. Reset the unit by disconnecting the power cord and then reconnecting it.

NOTE: UNIT WILL NOT FUNCTION UNTIL ERROR CODE HAS BEEN CLEARED.

2. Manually check to see if pump is operational by pressing the drain button. Check if the pump energizes and de-energizes properly. Additionally, check to see if any water purged from the system.
3. If you haven't cleaned the system recently, check the discharge line for an obstruction, then clean the balance of the pump system (see "Water Pump Maintenance and Application" on page 11 for details).
4. Replace the hoses and/or pump, if maintenance alone isn't sufficient.

Water Pump Maintenance and Application

► Normal use of water pump

1. Determine whether the forced drainage function is useful

When the power is on, press the "Drain" button, the water pump runs normally, the pumping water is normal, there is no vibration and noise, and the water flows smoothly.

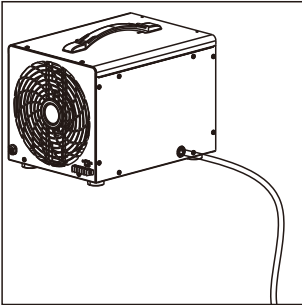

Gravity Drain

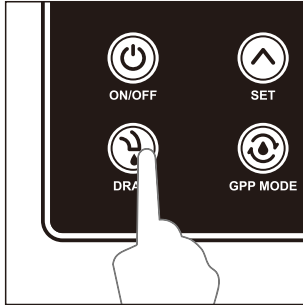

Drain

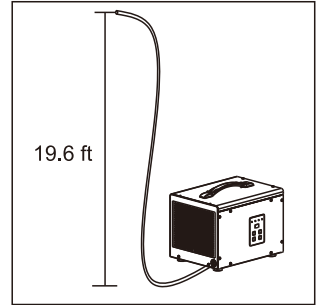

Pump Drain

2. Determine whether the automatic drainage function of the water pump water level line is useful

Press the "Ⓢ" button, the machine will perform dehumidification work. When the water level in the water collector reaches a certain height, the floating ball rises, and the water pump automatically enters the water pumping state, without vibration and noise, and the water flows smoothly.

3. Turn on the power and run the dehumidifier

If there is no abnormality in the forced drainage function and the automatic drainage function, the user can rest assured to use this equipment. If the water pumping is abnormal, the machine will display an error code of "E4", at this time, the user can simply repair the pump failure by himself. When the user is unable to repair, contact the manufacturer via email or phone.

► Usage of gravity drainage pipe (It can choose gravity drain or pump drain with the working environment).

For gravity drainage, the dehumidifier should be placed on a plane with a certain height. Pull out the screw tooth rubber plug at the outlet of the water collector of the dehumidifier, and plug in the water pipe. The condensate dripping from the coil will be discharged along the water pipe, which can be collected into the water storage container or discharged out of the room (Note: the water pipe should not be higher than the dehumidifier and should be discharged towards the ground).

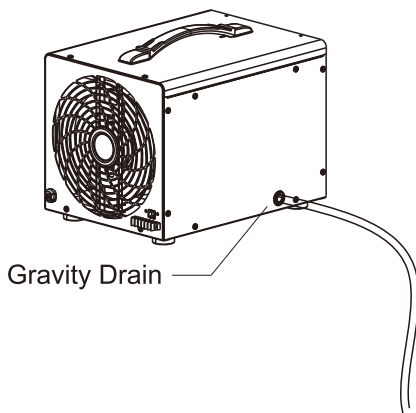

► Water pump function

1. Solve the inconvenience that gravity drainage can only place the machine at a fixed height, it can be put in various places in the house for work.
2. The drainage pipe can be laid at will, without space restriction, up to 19.6 ft.
3. It can be allowed to pump water automatically when it reaches a certain water level, or it can be pumped manually at any time, which is more flexible and convenient.
4. The advantages of the water pump itself, low noise, low vibration, small size, long life, self-priming function, simple maintenance and easy replacement.
5. Use the rubber stopper plug the drain hole when you use the pump drain.

► The fault judgment and maintenance method of the water pump

Problem judgment when "E4" error code appears:

1. The drainage hose is blocked or bent and deformed by foreign matter.
2. The drainage height exceeds the standard.
3. Water level switch failure.
4. Water pump failure or expiration of service life.
5. Internal water pump hose is blocked or bent and deformed by foreign matter.

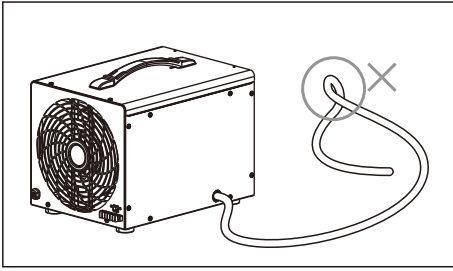

(1)

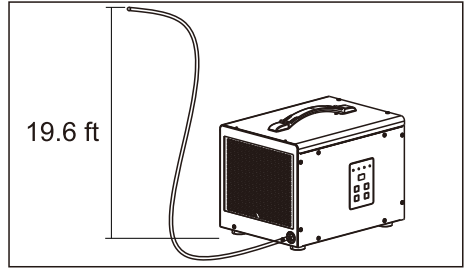

(2)

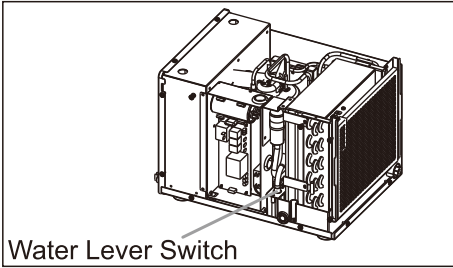

(3)

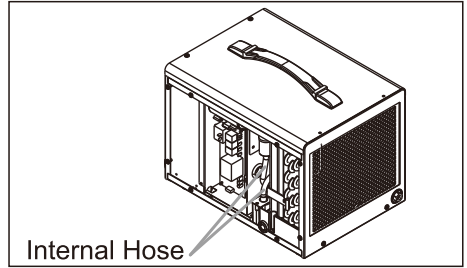

(5)

► Pump repair method

1. Use a Phillips screwdriver to unscrew the five screws on the water pump panel, you can see the fixed state of the water pump.
2. Use a Phillips screwdriver to loosen the two screws of the water pump fixing bracket.
3. Pull out the hose fixed in the water storage box, and take out the water pump for replacement.
4. Install the new water pump to its original position according to the above steps.

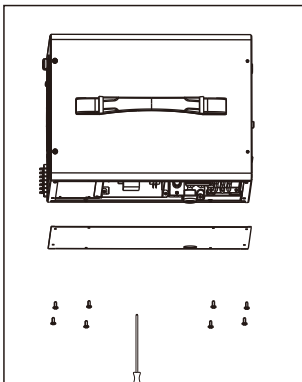

(1)

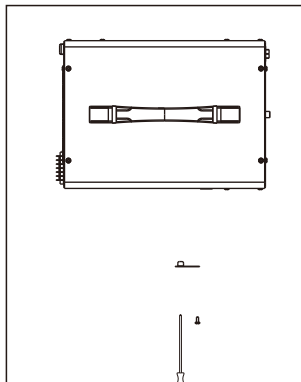

(2)

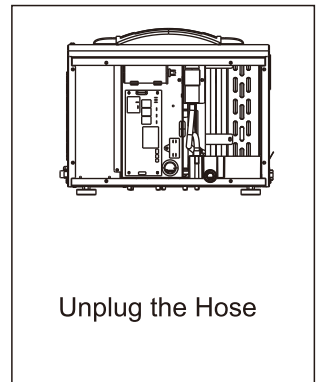

(3)

Sentinel HD35P Spare Parts

Sentinel HD35P - Parts	
Part#	Description
S-100	Remote Control Package(cable+remote)
S-108	Main Control Board
S-109	Display Board
S-110	RH/Temperature Sensor
S-601	Fan Motor
S-602	Complete Fan Assembly
S-603	Fan Capacitor
S-604	Compressor
S-605	Compressor Capacitor
S-606	Coil Assembly
S-607	RH/Temperature Sensor Cable
S-608	Display Cable
S-609	A1-A6 Cable Groups
S-610	Foot,adjustable
S-611	Condensate Pump Assembly
Sentinel HD35P - Filters	
Part#	Description
S-612	MERV-1 Filter

Limited Warranty

This limited warranty starts from the date of purchase. Alorair Solutions Inc. warrants to the original purchaser that this ALORAIR product is free from manufacturing defects in material or workmanship for the limited warranty period of:

Six (6) Month parts and labor. This includes the shipments charges for replacement parts or unit.

One (1) year parts and labor. This does not include the shipment charge to send the defective product back to be repaired or replaced.

Three (3) years parts and labor on Refrigeration System ONLY (Compressor, Condenser, and evaporator). Transportation cost, not included.

Five (5) years parts on Refrigeration System ONLY(Compressor, Condenser, and evaporator). Transportation cost, not included.

This limited warranty is valid only on products purchased from the manufacturer or ALORAIR authorized dealer and operated, installed, and maintained according to the instructions included in this user guide or furnished with the product. Alorair Solutions Inc will not provide in-home service during or after the warranty period. You may be responsible for the shipping charge to bring the product to the manufacturer for service.

To receive warranty service, the purchaser must contact ALORAIR at 888-990-7469 or support@alorair.com. A proof of purchase or order number is required to receive warranty service. During the applicable warranty period, a product will be repaired or replaced at the sole option of ALORAIR.

IMPORTANT NOTICE: Keep the item's packaging in case warranty service is required.

Limited Warranty Exclusions

This limited warranty covers manufacturing defects in materials or workmanship encountered in normal household, commercial or noncommercial use of this product and shall not cover the following:

- Damage occurs in uses for which this product was not intended for.
- Damage caused by unauthorized modification or alteration of the product.
- Cosmetic damage including scratches, dents, chips, and other damage to the product's finishes.
- Damage caused by abuse, misuse, pest infestation, accident, fire, floods, or other acts of nature.
- Damage caused by incorrect electrical line current, voltage, fluctuations, and surges.
- Damage caused by failure to perform proper maintenance of the product.

The use of this product in SPA or a room with OUTDOOR POOL invalidate or voids limited warranty.

Wiring Diagram

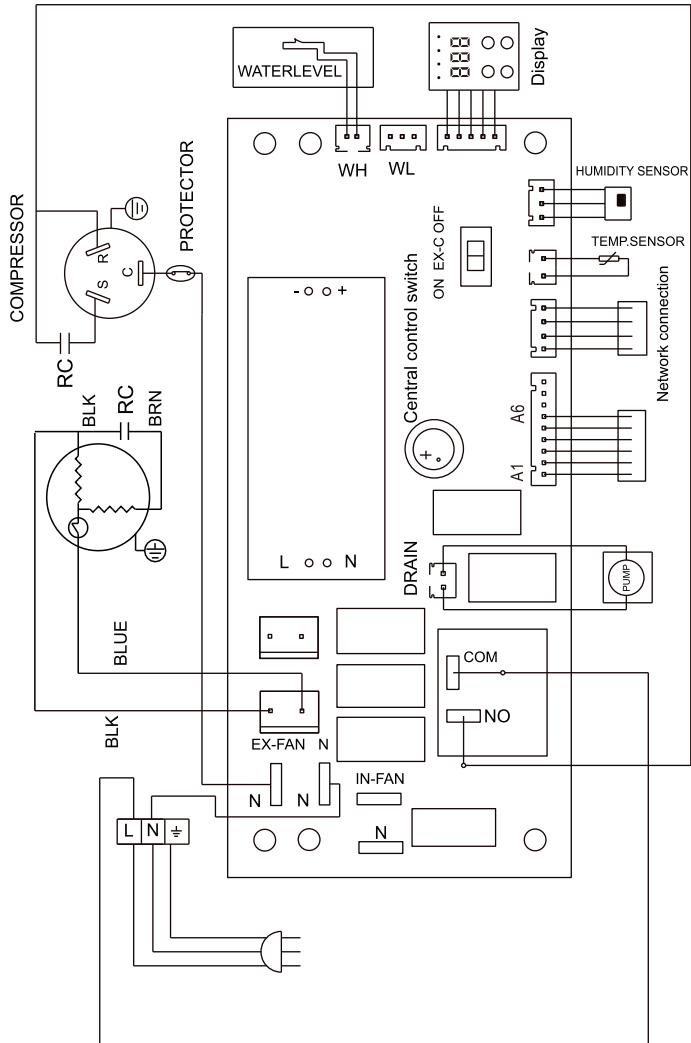

Restoration&Moisture&Ventilation



WARRANTY REGISTRATION CARD

Return To:
AlorAir Solutions

ORDER NUMBER: _____

MODEL: _____ **SERIAL #:** _____

INSTALLER: _____ **INSTALLATION DATE:** _____

NAME: _____

ADDRESS: _____

CITY: _____ **STATE:** _____ **ZIP:** _____

PHONE #: _____ **EMAIL:** _____



- ▶ If you have any questions, please feel free to contact us at [888-990-7469](tel:888-990-7469) or visit www.alorair.com
- ▶ Register your unit for warranty using this link: www.alorair.com/page/Warranty--Warranty-registration
- ▶ Warranty Registration <https://www.alorair.com> or scan this barcode to direct you to the warranty registration website.

