

# SANIBEL CHAISE LOUNGE

## INSTRUCTION MANUAL

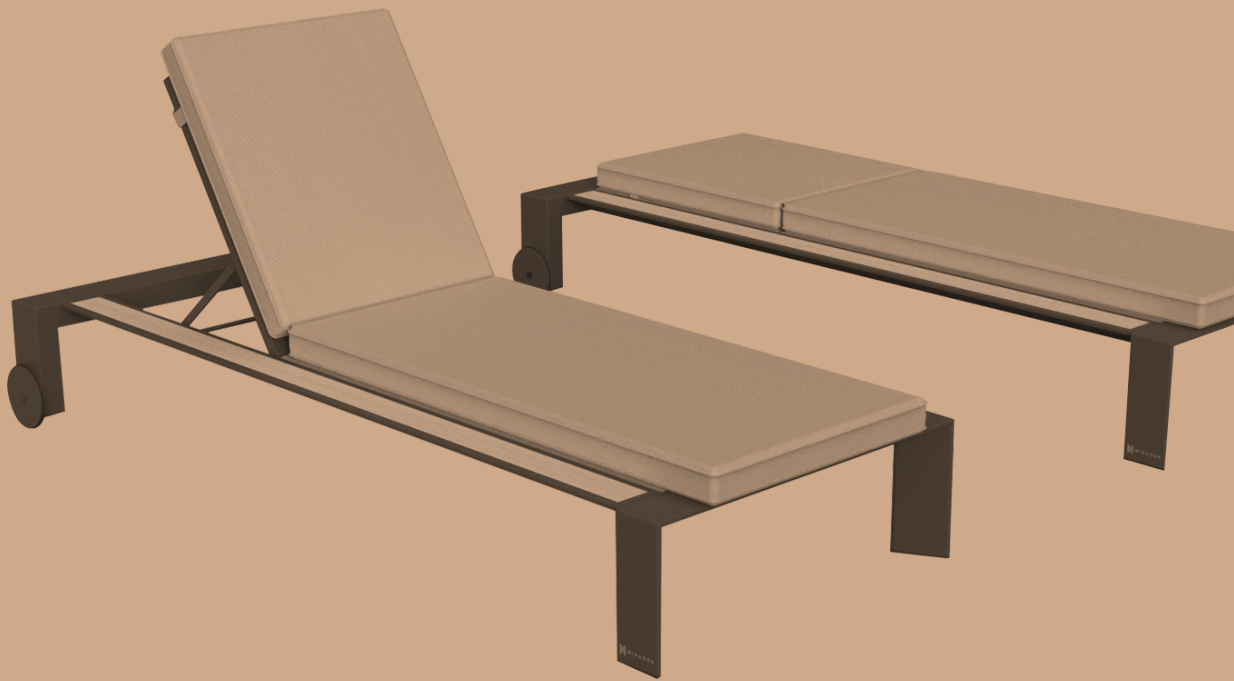

# THANK YOU FOR PURCHASING OUR MIRADOR SANIBEL CHAISE LOUNGE!



This manual will provide you with clear and detailed instructions on how to safely and correctly use and maintain your chaise lounge, to ensure it brings you many years of use and enjoyment.

## **IMPORTANT**

Please read the entire manual carefully before using your chaise lounge, and please ensure the manual is kept in a safe place for future reference.

Any use or modification to the chaise lounge not included in this manual shall be considered as improper use, which may cause considerable danger to users and property and will void the product warranty.

Please only use this product for its intended purpose within a residential environment. Failure to do so will void your warranty.

We reserve the right to make changes for product improvements.

For parts and customer service, please call +1 (877)-506-4777 in the U.S. and Canada (English and Spanish) Monday - Friday: 6:30 am - 4:30 pm, Saturday – Sunday: 8:30 am – 4:30 pm, Pacific Time. Or email: [support@miradoroutdoor.com](mailto:support@miradoroutdoor.com)

Digital instruction manual is also available on our official website [www.miradoroutdoor.com](http://www.miradoroutdoor.com) for your reference.

# TABLE OF CONTENTS



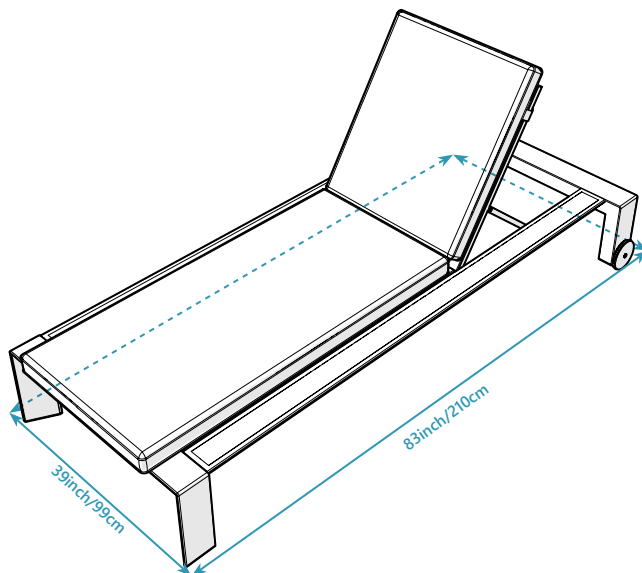







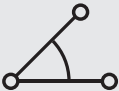

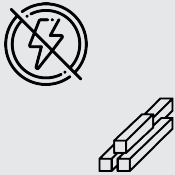
— Minimum Overall Size

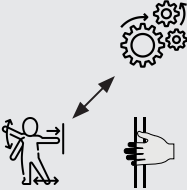

- Important Safety Advice	3
- Chaise Lounge Cushion Display	4
- Enjoy Your Chaise Lounge Cushion	5
- Care & Maintenance	6
- Warranty & Complaints Procedure	8
- Disassembly & Disposal of the Product	9

# IMPORTANT SAFETY ADVICE

For the safety of all persons using the chaise lounge, it is important to follow the safety guidelines below.

<p>Adjust and secure the angle of the chaise lounge back before using.</p>	<p>After prolonged use, we recommend you check all the fittings are tightened securely.</p>	<p>Work well away from power lines, particularly when handling metal parts.</p>	<p>Only use replacement parts that are approved by the manufacturer.</p>	<p>If damage is visible, stop using it immediately and contact authorized personnel for repair.</p>
			 <p>✓ Approved</p>	
<p>Always keep the entire base of the chaise in contact with the ground. If the chaise is wobbly, tilted, or unstable do not continue using the chaise until it is fixed or replaced.</p>	<p>Keep children, body parts and clothing away from the reclining position adjustment parts to prevent them from getting caught in it.</p>	<p>Do not exceed the weight limit when using the chaise lounge. (chaise: 264lbs/120kg)</p>	<p>Please recycle packaging where possible.</p>	<p>Changes to the design or configuration of equipment may not be made without consulting the manufacturer or authorized representative.</p>
				
<p>Do not place the chaise lounge in environments with flammable or caustic chemicals.</p>	<p>Do not stand on the chaise lounge, nor adopt unsafe sitting positions on it.</p>	<p>Dispose of all plastic bags safely. Keep them out of the reach of children.</p>		
				

# CHAISE LOUNGE CUSHION DISPLAY

Place the cushion on the chaise lounge and secure the fabric strips to the backrest.

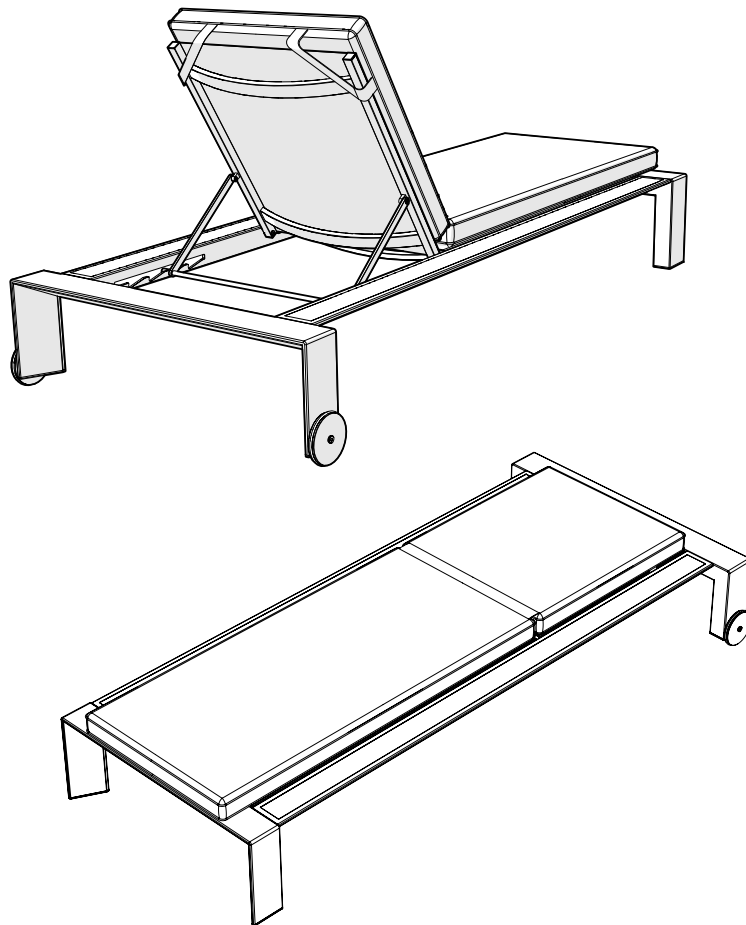

# ENJOY YOUR CHAISE LOUNGE CUSHION

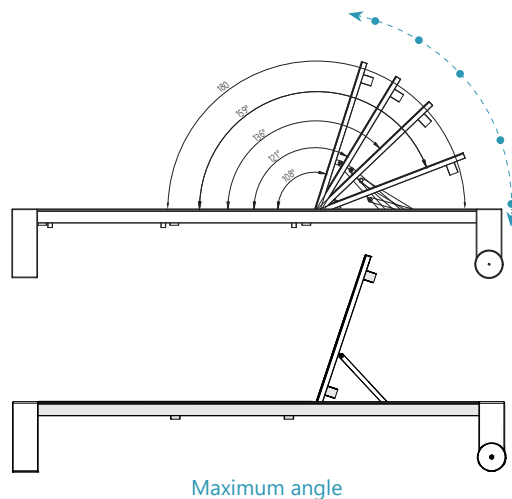
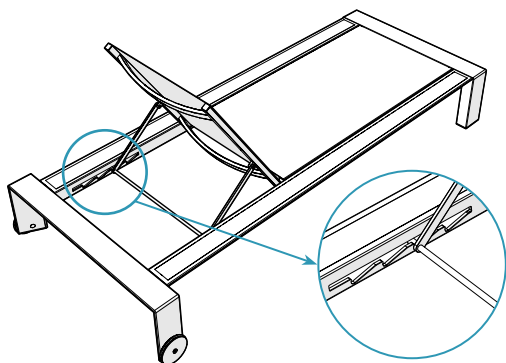

## Adjustable backrest:

The backrest has 5 reclining positions. Find and adjust to your preferred reclining position before use.



## Handy mobility:

Lift the side without wheels first and move it to the desired location.

Enjoy your Mirador Sanibel Chaise Lounge!

# CARE & MAINTENANCE

## FRAME

- Dust and dirt will collect on the frame and will require periodic cleaning.
- Use water or mild soap to clean.
- Be sure to drain any water accumulated inside the frames. Air dry or wipe with a soft clean cloth.

## CUSHION

- When the cushion becomes water-saturated, unzip the cushion cover to allow for ventilation and facilitate the drying process. Place the cushions upright with the zipper facing down to drain excess moisture more quickly.
- Store cushions indoors during inclement weather and rainy seasons.

## SUNBRELLA CUSHION FABRIC

- Dust and dirt will collect on the sunbrella fabric and will require periodic cleaning.
- Store it in a dry area and out of the elements when not in use or cover with commercially available outdoor furniture covers.
- Blot (don't rub) liquid spills with a clean, dry cloth.
- Brush off dirt before it becomes embedded in the fabrics and wipe up spills or clean soon after a spill occurs. The quicker you clean spills, the easier they can be to remove.
- Use water or mild soap to clean.
- Not machine washable.
- Solutions for fabric wrinkling.
  1. Use an iron on the synthetic setting. Avoid using steamers or the steam setting.
  2. Test a small, hidden area before ironing the whole piece due to varying iron temperatures.

### **Cleaning methods for different stains**

- Oil-based spills:
  1. Apply an absorbent such as corn starch, then remove with a straight edge.
  2. Spray on a mild cleaning solution of soap and water.
  3. Rinse the fabric thoroughly to remove all soap residue.
  4. Air dry.
- Mildew:
  1. Prepare a solution of 1 cup of bleach and 1/4 cup mild soap per gallon of water.
  2. Spray on entire area and allow to soak into the fabric for 15 minutes.
  3. Clean entire surface area with a sponge, clean towel or very soft bristle brush.
  4. Rinse thoroughly to remove all soap residue.
  5. Air dry.



## PHIFER SLING FABRIC

- Monthly, rinse the textilene fabric with clean water.
- Immediately clean spills by blotting with a clean cloth to absorb as much as possible.
- Avoid contact with sharp or abrasive objects to prevent damage or cuts to the textilene fabric.
- During off-season or extreme weather conditions, clean and fully dry the textilene fabric, store in a dry, cool place away from direct sunlight, and avoiding humid or moisture-rich environments to prevent mold.

### Cleaning methods for different stains

- General Rules (Best Practices):
  1. Don't wait to tackle stains and spills.
  2. Brush off excess dirt before wetting fabric.
  3. Dip your cloth, sponge, or scrub brush into your cleaning solution.
  4. Give your DIY cleaning solution time to sink in.
  5. Scrub gently with a soft bristled brush.
  6. Rinse with water thoroughly.
  7. Air dry.
- Mold/Mildew and Stubborn Stains:
  1. Brush off mold and mildew spots with a dry scrub brush or broom, removing as much dusty residue as possible.
  2. Combine 1/4 cup (60mL) dishwashing liquid and 1 cup (236.6mL) bleach per gallon (3.8L) of water.
  3. Spray onto affected areas with a spray bottle, saturating the fabric.
  4. If possible, allow to sit in the sun for 15 minutes, and then scrub gently with a soft-bristle brush until the spots disappear.
  5. Rinse with water thoroughly.
  6. Air dry.

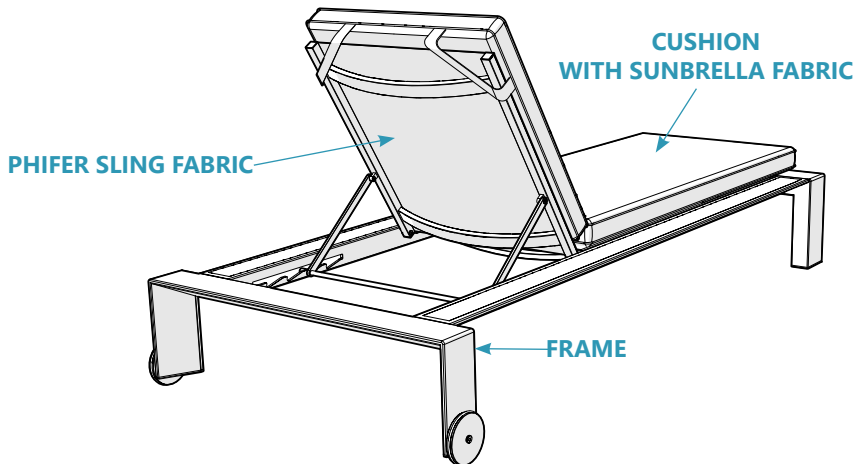



# WARRANTY & COMPLAINTS PROCEDURE

**For terms and conditions of our limited warranty, please visit [www.miradoroutdoor.com](http://www.miradoroutdoor.com) or contact your local Mirador sales representative.**

**Complaints procedure:**

- The complaint must include an order number or transaction number. Goods without an order number or transaction number are not covered under the warranty.
- The complaint must include a detailed description of the defect, the name of the company which assembled the product if 3rd party was used and the date when the defect was discovered.
- At Sorara Outdoor Living USA Inc's discretion, customer must offer supplier the photos/videos of the issue/damaged parts. Otherwise, supplier reserves the right to refuse replacement parts or credit.
- Please save a copy of your purchase receipt.

**Contact:**

**Customer Service:** [support@miradoroutdoor.com](mailto:support@miradoroutdoor.com)

**Need Assistance? Call** +1 (877)-506-4777

**Hours of Operation:**

**Phone Support:** Monday - Friday: 6:30 am - 4:30 pm, Saturday – Sunday: 8:30 am – 4:30 pm, PST.

**Email Support:** We are available 24 hours a day. Please allow up to 24 hours for a response.

**Chat With Us Online:** [miradoroutdoor.com](http://miradoroutdoor.com), Monday - Friday: 5:30 am - 2:00 pm, Saturday – Sunday: 8:30 am – 4:30 pm, PST.

**Note:** Our team is available to assist you during these hours. If you have any inquiries or require support outside of these hours, please leave a voicemail, send an email, or use our online contact form. We will get back to you promptly during the next available support hours. Thank you for choosing Mirador Outdoor!

# DISASSEMBLY & DISPOSAL OF THE PRODUCT

**Incorrect disassembly of the chaise lounge may lead to serious injury and product damage.**

**Disassembly should be assigned to qualified personnel with adequate training within the scope of occupational health and safety and knowledge within the scope of recycling.**

When the service life of the Mirador Sanibel Chaise Lounge is over, it is necessary to disassemble it for disposal and to sort the individual materials and components in compliance with the local regulations of your state, city and county.

more to  
enjoy

MIRADOR® is a registered trademark  
of Zhejiang Zhengte Co., Ltd.  
© 2024 Sorara Outdoor Living USA .  
All rights reserved.



Printed on 100%  
post-consumer  
recycled paper



FOLLOW US ON  
[WWW.MIRADOROUTDOOR.COM](http://WWW.MIRADOROUTDOOR.COM)  
@miradoroutdoor @MiradorOutdoor  
@miradoroutdoor @miraadoroutdoor