

# LED WALL PACK LIGHT

## Installation Guide



**WARNING**

### PLEASE READ ALL INSTRUCTIONS BEFORE ATTEMPTING INSTALLATION

- To prevent personal injury or product damage only licensed electricians should install.
- To avoid electric shock or component damage disconnect power before attempting installation or servicing.
- This product must be installed in accordance with the national electric code (NEC) and all applicable federal, state and local electric codes and safety standards.
- Disconnect product and allow cooling prior to servicing.
- Any alteration or modification of this product is expressly forbidden as it may cause serious personal injury, death, property damage and/or product malfunction.
- To prevent product malfunction and/or electrical shock this product must be properly grounded.
- This luminaire is designed to operate in ambient temperatures ranging from -30°C to 40°C and to be horizontally mounted with the LEDs facing down.
- WALL PACK only.

## 1. Unpacking

Thoroughly inspect the fixture for freight damage. Freight damage should be reported to the delivery carrier.

## 2. Installation

1) .Unscrew the heat sink and cover of driver as photo.

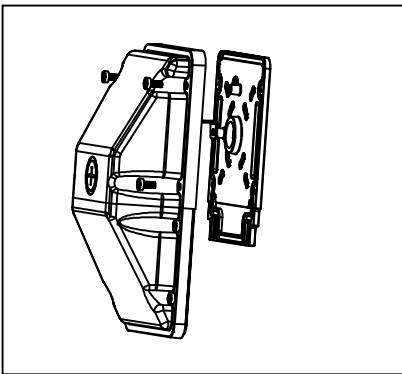

2) .Fix the cover of driver and waterproof cotton pad on the wall.

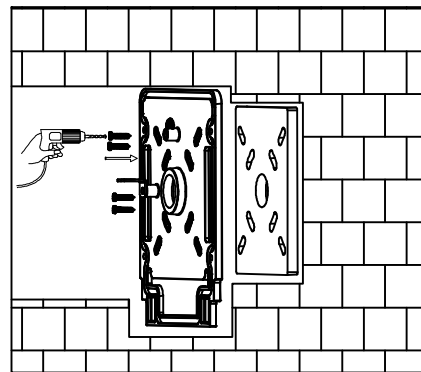

3) .After installation, daub the gap between installation board and wall by waterproof glue to avoid leaking, Hang the rope to cover of driver to avoid falling. And connect AC wire.

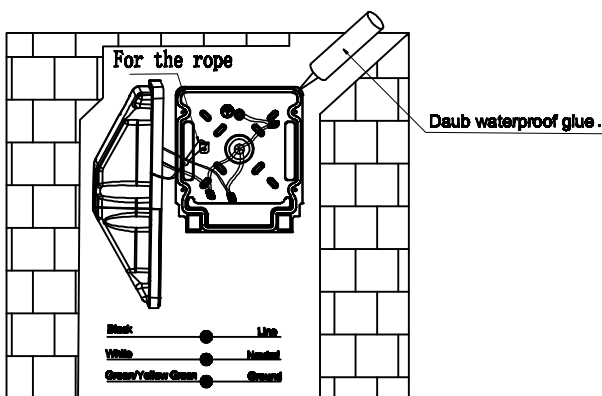

4) .Screw the heat sink to cover of driver

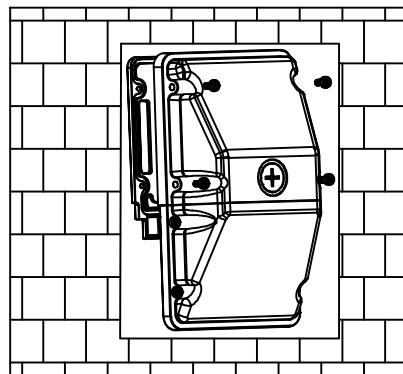

## 3. Checking

- 1). Does all the wires connect in a correct way as the pictures show below?
- 2). Is the ground lead installed appropriately?
- 3). make sure the photocell function well.

