

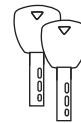

**Multifunction Pistol Safe (RP19001E)
Instruction Manual**

RPNBSafe delivers security exactly where you want it.

Box Contents

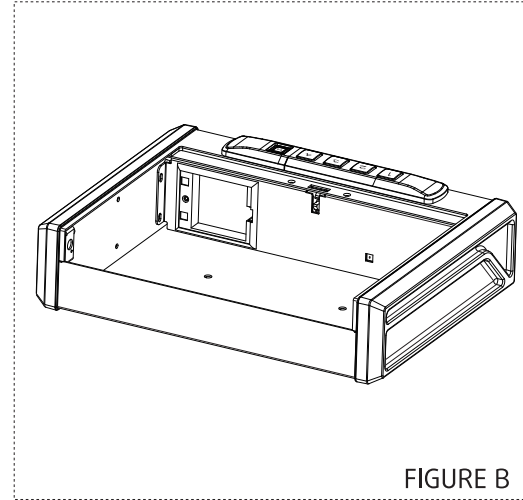
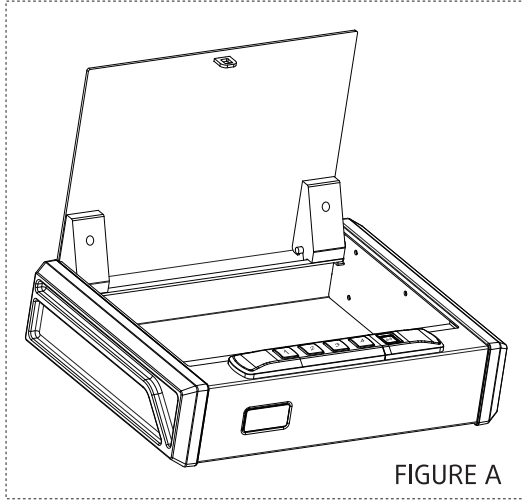

- RPNB® Safe
- RFID Key Fob
- RFID Card

- Hardware Mounting Kit
- Backup Keys (2)
- Owner's Manual/Quick Start Guide

Warnings

To prevent damage to your RPNB® unit or injury to yourself or to others, read the following safety precautions before using this unit.

DO NOT PLACE OR STORE THE BACKUP KEYS INSIDE THE SAFE AT ANY TIME. IF THE BATTERY FAILS, YOU WILL BE UNABLE TO OPEN THE SAFE.

DO NOT expose to extreme heat or cold. Battery power may be affected.

DO NOT store loaded guns in this unit. Firearms are serious in nature and must be handled with respect. Store responsibly.

ALWAYS check to make sure door has latched when closing; Lid requires a firm press and locks automatically.

Disclaimers:

Neither seller nor manufacturer shall be liable for unauthorized access, any injury, loss or damage to personal property direct or consequential, arising out of the use of, or the inability to use the RPNB® Safe.

The user shall determine the suitability of the RPNB® Safe before the intended use and user assumes all risk and liability whatsoever in connection therewith, RPNB® Safe are not intended to protect against environmental hazards including fire and water.

Be sure and follow all local and state firearm laws.

DO NOT operate a firearm without proper training and experience.

Battery Installation

- 1 To get started, remove the key cover (see Figure C), and insert one of your backup keys into the keyhole at the front of the safe. Push key in and rotate the key 30 degrees clockwise to open the safe.
- 2 Remove crate foam insert. Locate the battery compartment door on the inside of the safe directly below the keypad (see Figure D).
- 3 Open the battery cover and insert the 4 AA alkaline batteries (not included) into the battery compartment. Note that pay attention to the "+" and "-" signs. The "-" end of the batteries go against the spring inside of the compartment.
- 4 When the batteries are inserted correctly you will hear a short beep.
- 5 Once you hear the beep, place the batteries cover. You are now ready to program your safe.

IMPORTANT :

- Use the NEW AA alkaline battery. Using other batteries may cause unusable conditions.
- Your RPNB® safe will automatically lock when you fully close the lid.

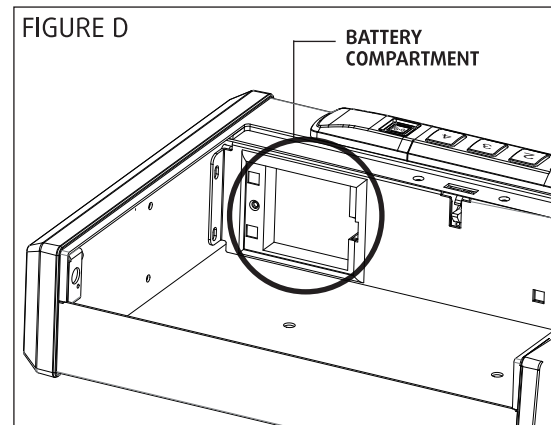
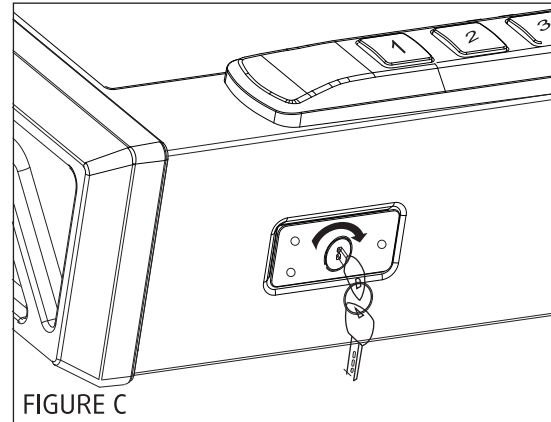

Master Code Programming

First time users should change the default code as soon as possible to prevent unauthorized access to your safe, so it should be kept confidential.

TIP: Code Requirements

- Your code can be a minimum of 4 and a maximum of 8 digits. For your security, the safe will time out and sleep for five minutes if 5 incorrect entries are made. The safe can still be opened by using the backup keys override.
- Two keys cannot be pressed simultaneously.
- Programming a new code will overwrite your previous code.

- 1 Enter default code 1-2-3-4 on the keypad to open your safe.
- 2 With the safe open, press the "PROGRAM" button once and release it (see Figure E), all keys (1-4) will light up twice with the double beeps.
- 3 Enter your NEW master code.
- 4 Press the "PROGRAM" button once and release it, all keys (1-4) will light up twice with the double beeps. This tone confirms that the password has been reset. (If your code is 8 digits, you don't need press the "PROGRAM" button to confirm.)
- 5 Now test the code. If you make a mistake and the new code will not work, simply start over with step 2.

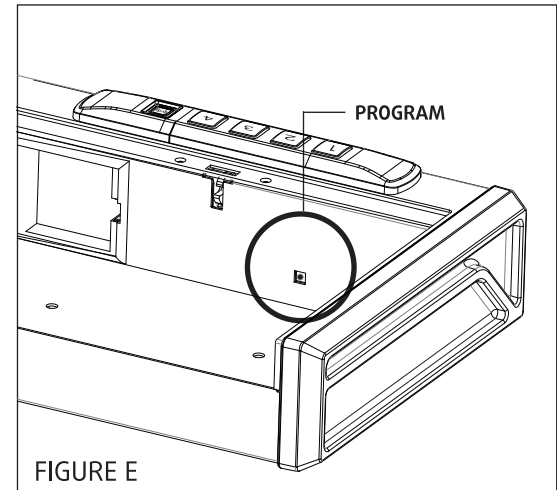

Key Card Programming

- 1 Open the safe.
- 2 Program key card by pressing the "PROGRAM" button once (see Figure F) and release it, all keys (1-4) will light up twice with the double beeps.
- 3 Place the key card over the keypad approximately 1/4" from the surface for the scan (see Figure G).
- 4 When the safe beeps twice and all keys flash twice remove your key card.
- 5 Now test the key card, pressing any key (1-4) then place your key card over the RFID induction zone. If you make a mistake and the new key card will not work, simply start over with step 2.

Helpful Tips:

- To silence the audible sound of the electronics, hold the "1" button for 4 seconds until you hear one beep and all keys will flash together. To unmute the keys, repeat this step.
- Before using the key fob/key card, you must press anyone of "1,2,3,4" button at first, then place your key fob/key card over the RFID induction zone to open the safe.

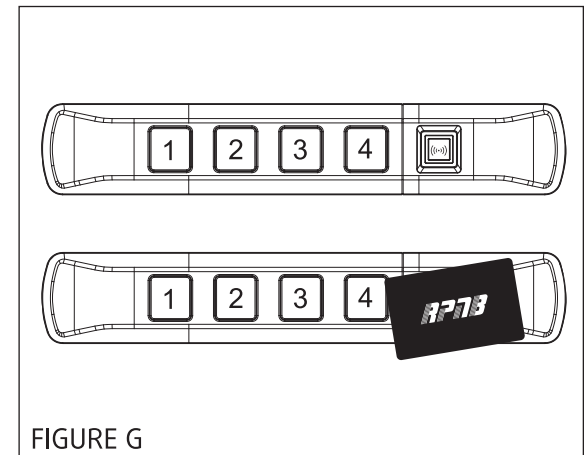
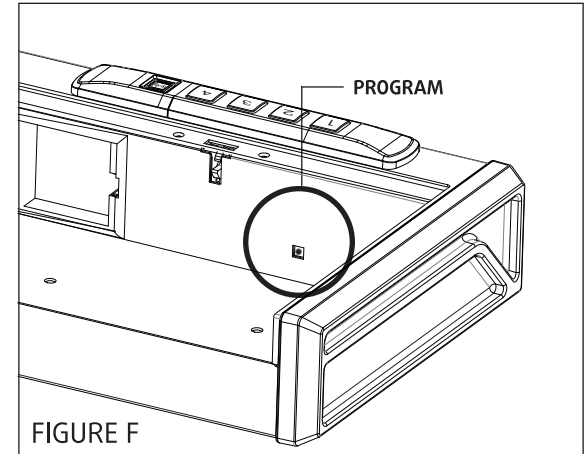

Key Fob Programming

- 1 Open the safe.
- 2 Program key fob by pressing the "PROGRAM" button once (see Figure H) and release it, all keys (1-4) will light up twice with the double beeps.
- 3 Place the key fob over the keypad approximately 1/4" from the surface for the scan (see Figure I).
- 4 When the safe beeps twice and all keys flash twice remove your key fob.
- 5 Now test the key fob, pressing any key (1-4) then place your key fob over the RFID induction zone. If you make a mistake and the new key fob will not work, simply start over with step 2.

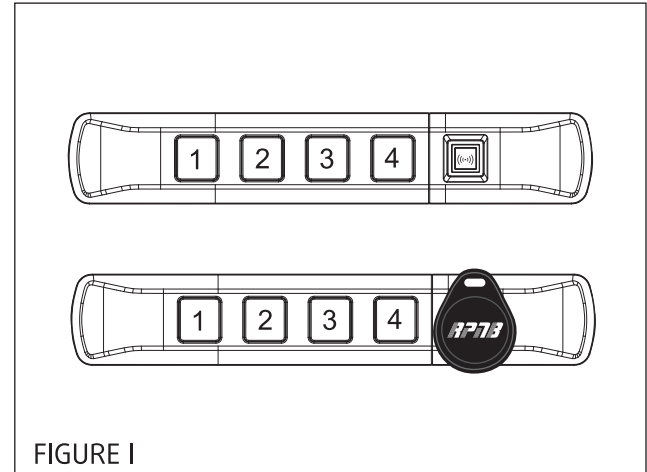
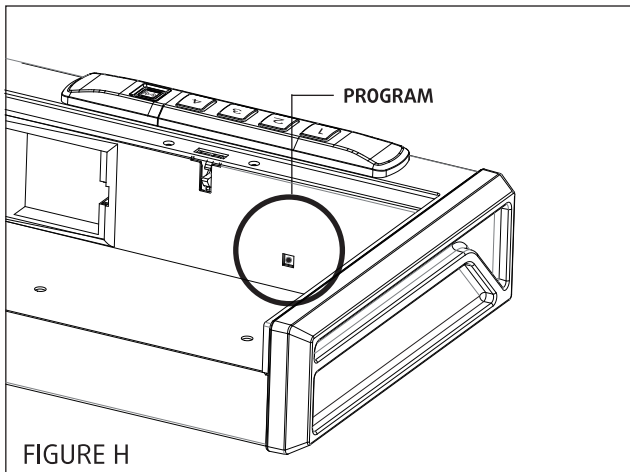

Deleting Key Card & Key Fob

- 1 Open the safe.
- 2 Press and hold the "PROGRAM" button (**5 seconds**), all keys (1-4) will light up blue twice with the double beeps and you could release the "PROGRAM" button.(see Figure J)
- 3 Now test the key card/key fob. If you make a mistake, simply start over with step 2.

TIPS:

- This procedure will not affect the keypad master code.
- Keypad master code can not be deleted on the safe, you should program a new code to overwrite your previous code.

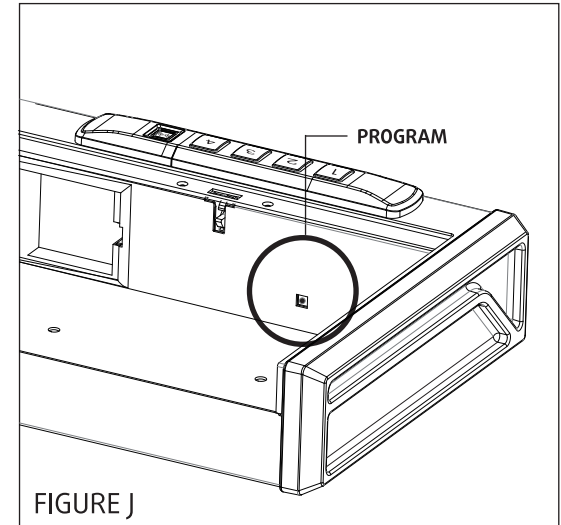

Low Battery Warning

If all keys will light up blue 10 times with 10 times beeps when opening the safe by electronic way, your battery level is critically low and your safe needs to be replaced the 4 new batteries.

IMPROTANT

Use the NEW AA alkaline battery. Using other batteries may cause unusable conditions.

Securing Your Safe

There are some mounting screws included to mount your RPNB® safe to a flat surface using the pre-drilled holes on the bottom.

Using the Mounting Screws

TIP: Make sure you have enough clearance for the lid to open properly before mounting the safe.

- 1 Position the safe on a flat surface where you want to mount it.
- 2 Use a pencil to mark the holes for drilling.
- 3 Drill pilot holes.
- 4 Position safe in place and install screws through safe into pilot holes. Tighten screws.

IMPOTANT

Mounting the safe vertically so that the door flips upward will result in incomplete opening of the safe due to weight. The door will open if the safe is mounted vertically so that door opens down or to side.

Customer Support/Warranty

Customer Support

If you have a problem with your RPNB® safe that is not answered in the this manual, we encourage you to email us: CUSTOMERSUPPORT@RPNBSAFE.COM

How shall I view tutorial videos?



RPNB[®]

<http://www.rpnbsafe.com>

- 1 Go to our website via: **www.rpnbsafe.com**
- 2 Select the "**Customer Service**" on the navigation bar
- 3 Click "**How To Video**"
- 4 Select the product model you purchased

How shall I replace keys?

- 1 Go to our website via: **www.rpnbsafe.com**
- 2 Select the "**Customer Service**" on the navigation bar
- 3 Click "**Replace Keys**"
- 4 Fill in the required information

How shall I order accessories?

- 1 Go to our website via: **www.rpnbsafe.com**
- 2 Select the "**Customer Service**" on the navigation bar
- 3 Click "**Order Accessories**"
- 4 Fill in the required information

 More online at www.rpnbsafe.com under support

Linked Warranty (Terms and Conditions)

RPNB® is committed to building high quality products and will make every effort to ensure our products are free from any defects. We guarantee your safe will be free of defects in materials or workmanship for a period of one year from the date of original. This warranty does not cover abuse, misuse, use in any manner for which is not designed, neglect, modification, damage in advertently caused by the owner; accidents, and/or tampering.

If you safe is determined to be defective and we are responsible for the cause we will have it repaired at our expense, or we will send a new replacement at no cost to you. You will be required to return your existing unit as well as all included accessories to RPNB® prior to replacement of the defective unit along with your order of purchase.

If it is determined your safe needs to be returned our customer support team will provide you with a return detail.

Please have the following information available when contacting us:



- Purchaser's name and mailing address, email address, and phone number
- Online order number
- Detailed description of problem

NEITHER SELLER NOR MANUFACTURER SHALL BE LIABLE FOR ANY INJURY, LOSS OR DAMAGE, DIRECT OR CONSEQUENTIAL, ARISING OUT OF THE USE OF, OR THE INABILITY TO USE THE RPNB® SAFE.

How shall i talk to them?

Go to Your Orders, find your order in list, and click get product support.

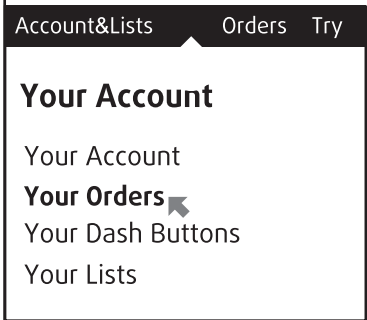
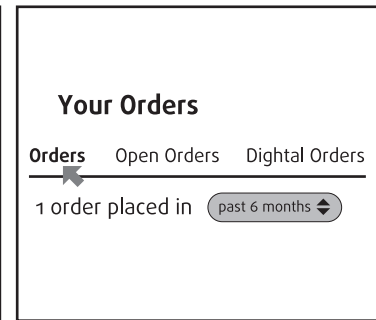
You can e-mail the seller by doing the following:

 <p>Account&Lists Orders Try</p> <p>Your Account</p> <ul style="list-style-type: none">Your AccountYour Orders ←Your Dash ButtonsYour Lists	 <p>Your Orders</p> <p>Orders Open Orders Digital Orders</p> <p>1 order placed in past 6 months ▾</p>	 <p>Get product support →</p> <p>Write a product review</p> <p>Archive order</p>	 <p>Talk to an expert</p> <p>Figure out and fix what' s wrong,get</p> <p>phone chat →</p> <p>if a new window doesn' t appear,chan</p>
<p>1.Go to your account find the order</p>	<p>2.Find your order item</p>	<p>3.Click get product support</p>	<p>4.Give the seller 24hours to respond</p>

 Please email us to get a special **VIP** discount code before your next order.

 Problem with the order? Please email us, give us a chance to help you firstly.

 **Satisfied with us.**

Hum, this people is nice, i can give them a positive reviews to tell people they are selling good products, doing the right thing.



RPNB[®]

Dear Customer:
Thank for your business
— BEST WISHES FOR YOU —



Customer Support Hours:

Monday - Friday 9:00AM - 6:00PM (PST) Saturday - Sunday 9:00AM - 12:00PM (PST) Excluding Holidays

Hours subject to change

Customer Service Department Contact: customersupport@rpnbsafe.com