









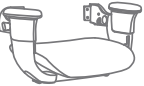

ASSEMBLY INSTRUCTIONS

For more information: www.eurekaergonomic.com or www.smartmotionergonomics.com

Brought to you by:
EUREKA™
 ERGONOMIC

“POWERED BY”

smartmotion ergonomics™
 Natural.Human.Motion

A x 1 	F x 1 
B x 1 	G x 5 
C x 1 * Note: If purchased with headrest 	J x 2 
D x 1 	I x 2 
E x 1  * Gas Lift	H₁ x 4 H₂ x 4 H₃ x 4 
	K₁ x 1 K₂ x 1 

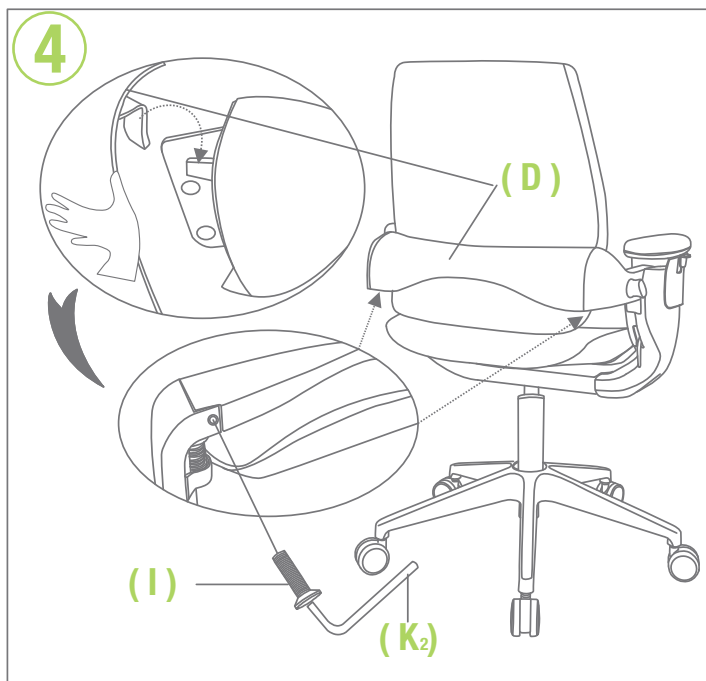
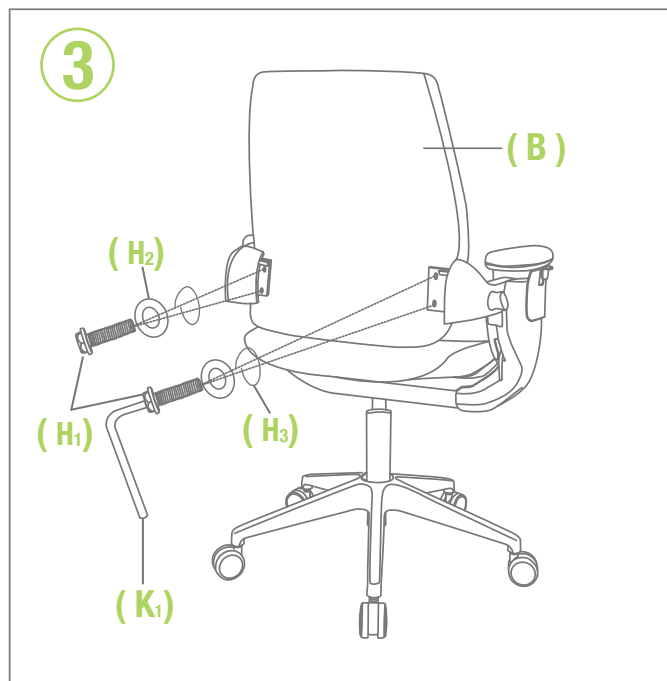
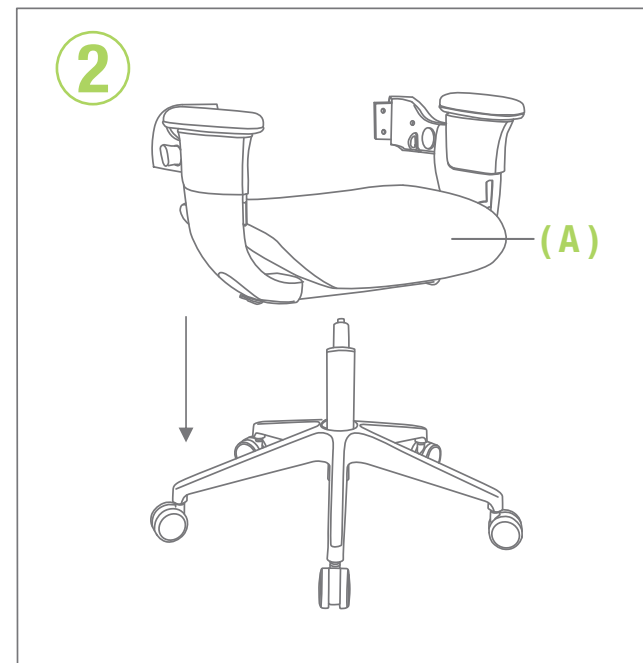
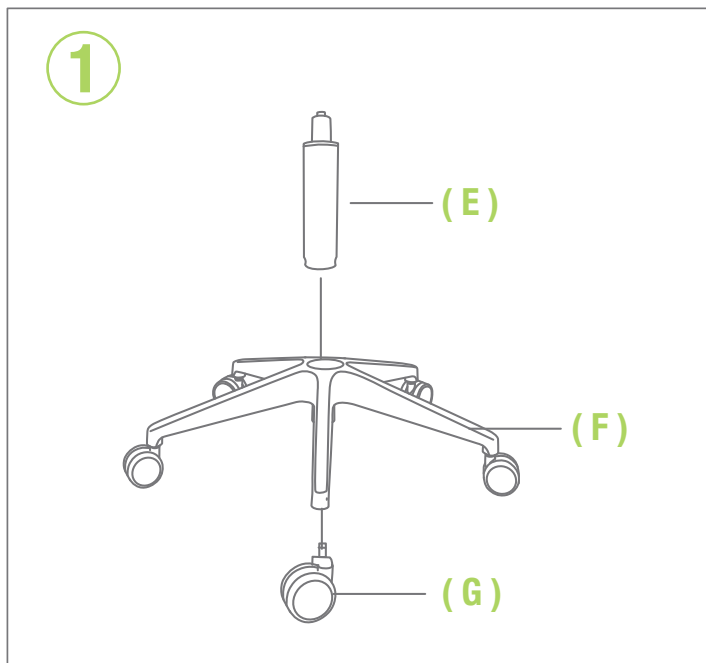

PERSONALIZE YOUR CHAIR

For more information: www.eurekaergonomic.com or www.smartmotionergonomics.com

Brought to you by:
EUREKA[™]
ERGONOMIC

“POWERED BY”

smartmotion ergonomics[™]
Natural.Human.Motion

5 Easy Steps

to Getting Started to Enjoy the Benefits of ErgoMotion

1. Back Depth Adjustment

Turn knob to 1 of 3 settings to fit body size.



2. Backrest Tension Adjustment

Adjust to low or high tension settings to select your preferred recline tension.



3. Backrest Tilting Movement

This happens automatically.



4. Chair Height Adjustment

Lift or lower your chair to the preferred height.



5. Armrest Adjustment