

# Officelab

## User guide

Desktop Thermal printer PR02002

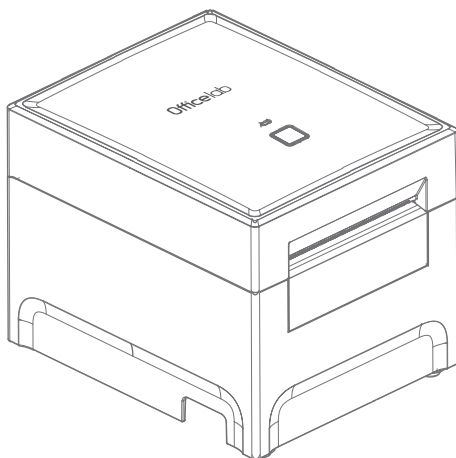

English . Deutsch . Français . Italiano . Español



This is a brief version of PR02002 instruction manual. For more information about driver installation on Mac OS and Windows systems, printing with serial cable or Ethernet cable, NV LOGO printing, and user tools (for Windows system only), please refer to the video illustration and user guide in the USB generic flash disk.

If you have any problem or suggestion with our product, please contact us via support@inateck.com.

### Safety Guidelines

1. Do not plug in/out the power cable to/from power source when the switch of the printer is toggled to



2. Do not use or store the printer in the environment with high temperature, high humidity, or serious pollution.
3. Connect the printer's power adapter to a suitable grounded socket. Avoid using the socket on which high-level power consumption equipment is working, which can cause power voltage fluctuations.
4. If the printer will not be used for a long time, please unplug the power adapter.
5. There's a cutter on the top lid of the printer. When you open the top, please make sure it is completely open, so the cutter won't hurt your finger. You can refer to the pictures below:

Not Completely Open

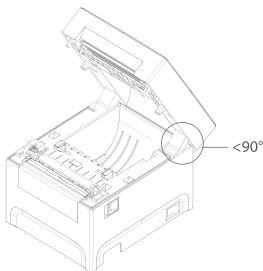

Completely Open

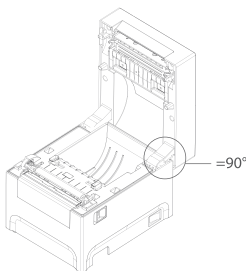

## 1. Package Content

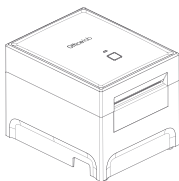

Printer

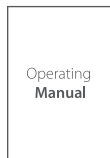

Operating Manual

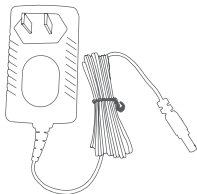

Power Adapter

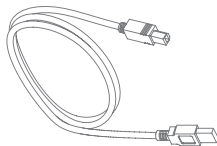

USB cable

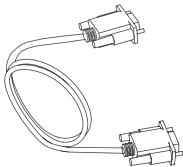

Serial Cable

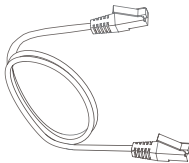

Ethernet Cable



USB flash Drive



Cleaning Pen



Thermal Receipt paper



Directly-heated Thermal Paper  
Cleaning Pen Instruction Manual



## 2. Main Parts Illustration

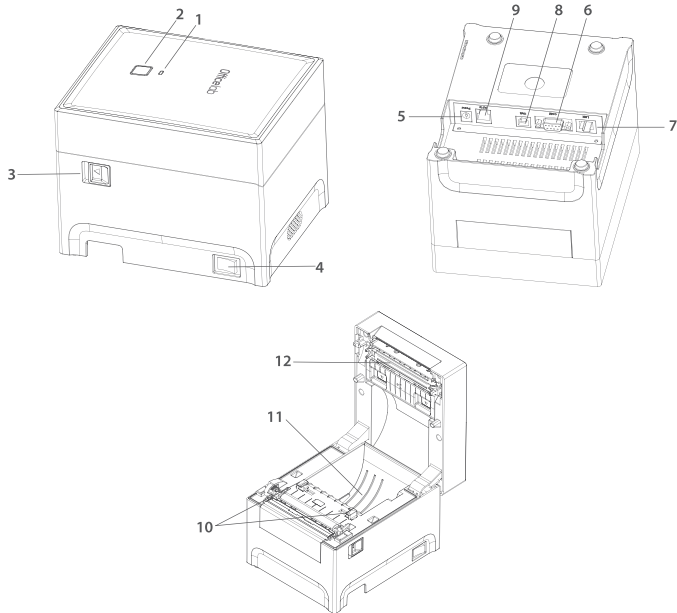

- 1) Indicator
- 2) Form Feed Button
- 3) Opening Button
- 4) Power Switch
- 5) Power Port
- 6) Serial Port Interface(RS-232)
- 7) Network Interface(RJ-45)
- 8) USB Port
- 9) Cashbox Port(RJ-12)
- 10) Movable Paper Conveyance Device
- 11) Paper Holder
- 12) Printhead

### Note: Power Switch

Press down the power switch to "I" turn on the printer.



Press down the power switch to "O" to turn off the printer.

Please use the original power adapter that comes with the package to avoid unsatisfactory printing result or damage to the printer.

### 3. How to Use

3.1 Make sure the power switch is at "Off" status and then connect the printer to power source.

EN

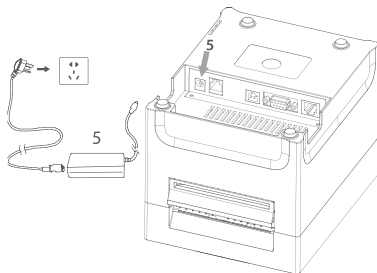

#### 3.2 Connect cable

3.2-1 Use the USB cable to connect the printer to a computer.

3.2-2 Plug the serial cable into the serial port.

3.2-3 Plug the RJ45 Ethernet cable into the network interface.

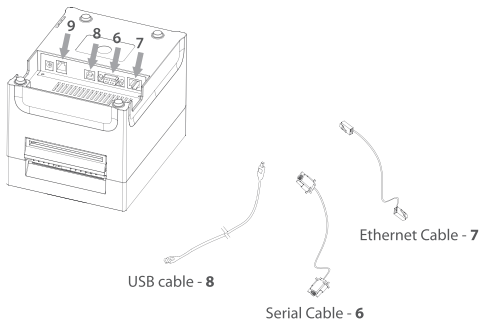

3.3 Toggle the power switch to "I" to turn on the printer.

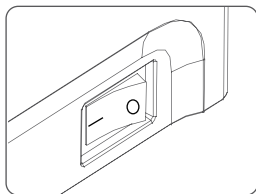

3.4 Press the top opening button to open the internal paper compartment; install a roll of paper, and move the paper inlet clip to clamp the paper.

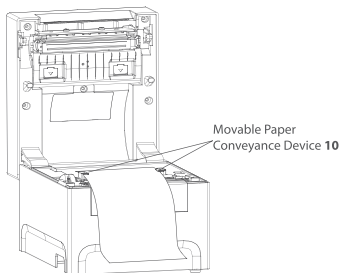
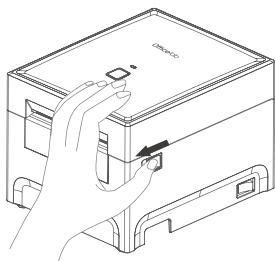

#### 4. Installation of Driver

In the USB flash drive users can find the drive and its installation instruction (for both Mac and Windows). They are also available on the official site [www.inateck.com](http://www.inateck.com).

#### 5. Print the self-check page

When the printer is power-off, long press the form feed button and then turn on the printer. Hold the form feed button for 3s and then loosen. The printer will send a self-check page.

#### 6. Indicator Status and Troubleshooting

Indicator	Status	Trouble Shooting
Green	There's paper in the paper holder. The printer is power-on and under normal working status.	/
Red with Two Beep Alerts	Top not closed and paper holder empty.	Check whether the top of the printer is properly closed. Check whether the paper is properly installed.

#### 7. Treatment for Jammed/Stuck Paper

Turn off the printer and open the top. Pull out the jammed/stuck paper from the inlet and install new one.

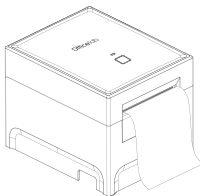

 Warning: Be careful with possible scald. The temperature of printer is high when it just stops working.

**Note:**

If paper gets stuck, please check if there is any adhesive or dirt residue on the print head. If so, wipe them out with the alcohol cleaning pen included in the package. The printer can resume working when the alcohol gets dried.

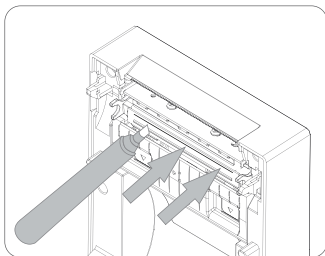
**EN****8. FAQ:****Q: The printer refuses to work**

Failure	Possible cause	Solution
The indicator does not light up, and the printer does not work	The printer is disconnected from power	Connect the printer to power supply
	The printer is not turned on	Toggle the printer's switch to ON
	The circuit board is damaged	Please feel free to email us at support@inateck.com

**Q : Problems in the printing process**

Failure	Possible cause	Solution
Unclear or smeared printing	Paper roll is installed incorrectly	Check if the paper is loaded correctly
	Low print density setting	User tools are included in the USB generic flash disk packaged. You may install the tools to adjust the printing density.
	Paper does not meet the requirements	Please use Officelab thermal receipt paper or use recommended thermal receipt paper
	Dirty print head or print rubber roller	Clean the print head or print rubber roller

**9. Contact Us**

Please feel free to email support@inateck.com if you have any query regarding Officelab PR02002 . We will gladly assist you.

Dies ist eine Kurzfassung der Bedienungsanleitung des PR02002. Weitere Informationen zur Treiberinstallation auf Mac OS- und Windows, zum Drucken über ein serielles oder Ethernet-Kabel, zum Drucken von NV LOGO oder zur Verwendung der Benutzer-Tools (nur für Windows) finden Sie auf dem USB-Stick mit detaillierter Video-Illustration und Benutzerhandbuch.

Wenn Sie Probleme mit unserem Produkt, oder Hinweise haben, kontaktieren Sie uns bitte über support@inateck.com.

### Sicherheitshinweise

1. Ziehen Sie das Netzkabel nicht an die/aus der Stromquelle, wenn der Schalter des Druckers auf "ON" geschaltet ist 
2. Verwenden oder lagern Sie den Drucker nicht an Orten mit hoher Temperatur, hoher Luftfeuchtigkeit oder starker Verschmutzung;
3. Schließen Sie den Netzadapter des Druckers an eine geeignete geerdete Steckdose an. Vermeiden Sie es, dieselbe Steckdose mit Motoren oder anderen Geräten mit hohem Stromverbrauch zu verwenden, da dies zu Schwankungen der Netzspannung führen kann;
4. Wenn der Drucker für längere Zeit nicht benutzt wird, ziehen Sie den Netzadapter vom Gerät;
5. An der oberen Abdeckung des Druckers befindet sich ein Messer. Wenn Sie den Deckel öffnen, achten Sie bitte darauf, dass er vollständig geöffnet ist, damit das Messer Ihre Finger nicht verletzt. Sie können sich auf die folgenden Bilder beziehen:

Nicht vollständig geöffnet

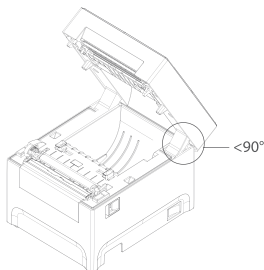

Vollständig geöffnet

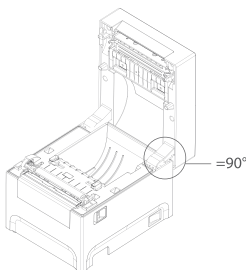

## 1. Packungsinhalt

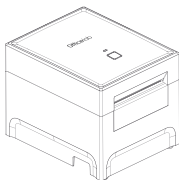

Drucker

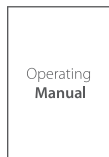

Bedienungsanleitung

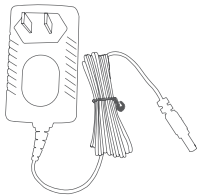

Netzteil

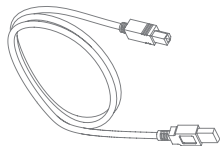

USB-Kabel

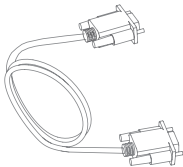

Serielles Kabel

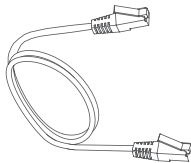

Ethernet-Kabel



USB Drive



Reinigungsstift



Thermo-Belegpapier



Bedienungsanleitung direktes  
Thermopapier, Reinigungsstift

## 2. Abbildung der Hauptkomponenten

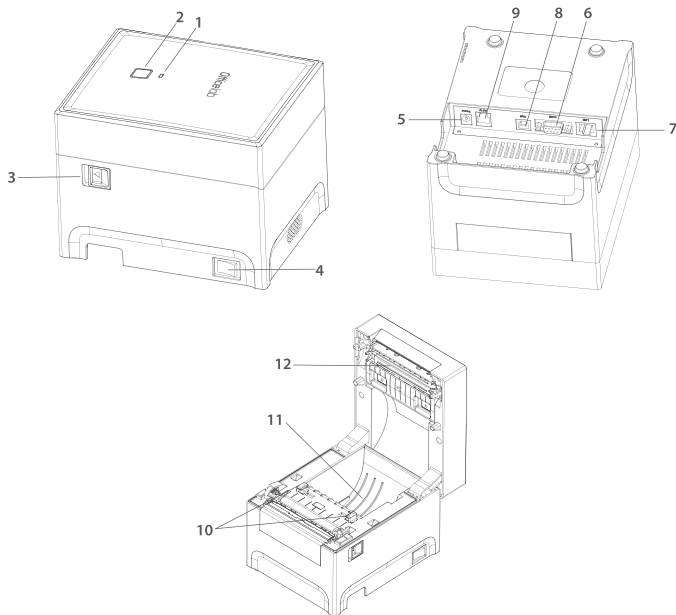

- 1) Anzeige
- 2) Form-Feed-Button (Formularvorschub-Taste)
- 3) Öffnungstaste
- 4) Netzschalter
- 5) Netzanschluss
- 6) Serielle Schnittstelle(RS-232)
- 7) Netzwerk-Schnittstelle (RJ-45)
- 8) USB-Anschluss
- 9) Cashbox-Anschluss(RJ-12)
- 10) Bewegliche Papierfördereinrichtung
- 11) Papierhalterung
- 12) Druckkopf

### Hinweis: Hauptschalter

Stellen Sie den Hauptschalter auf "I" um den Drucker einzuschalten.



Stellen Sie den Hauptschalter auf "O" um den Drucker auszuschalten.



Verwenden Sie nur das mitgelieferte Netzteil, um Fehler im Druckergebnis und Schäden am Drucker zu vermeiden.

### 3. Benutzung

3.1 Stellen Sie sicher, dass der Netzschalter auf "OFF" steht, und schließen Sie den Drucker an die Stromquelle an.

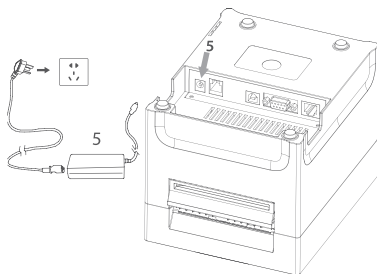

3.2 Kabel anschließen

3.2.1 Verwenden Sie ein USB-Kabel, um den Drucker mit einem PC zu verbinden;

3.2.2 Stecken Sie das serielle Kabel in die serielle Schnittstelle;

3.2.3 Stecken Sie das RJ45-Ethernet-Kabel in die Netzwerkschnittstelle;

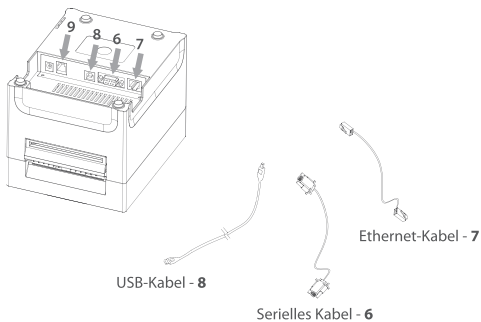

3.3 Schalten Sie den Netzschalter auf "I", um den Drucker einzuschalten;

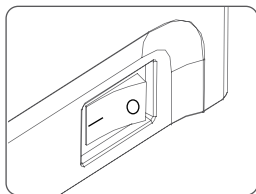



3.4 Drücken Sie die obere Öffnungstaste, um das interne Papierfach freizulegen; legen Sie eine Papierrolle ein, bewegen Sie den Papiereinlassclip, um das Papier einzuklemmen;

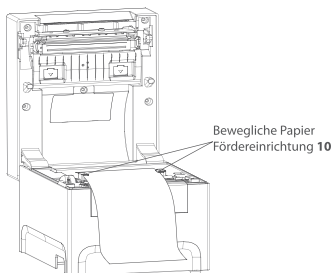
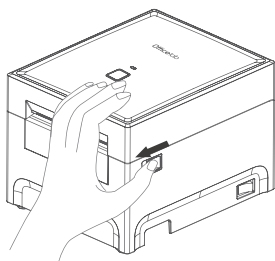

#### 4. Treiberinstallation

Auf dem mitgelieferten USB-Stick befinden sich Treiber und eine Installationsanleitung (Für Windows und Mac). Sie finden Treiber und Installationsanleitung auch auf der offiziellen Website [www.inateck.com](http://www.inateck.com).

#### 5. Drucken der Selbstkontrollseite

Wenn der Drucker ausgeschaltet ist, drücken Sie die Vorschubtaste lange und schalten Sie den Drucker ein. Lassen Sie die Taste erst los, wenn der Drucker für 3s eingeschaltet ist. Der Drucker wird eine Selbstkontrollseite drucken.

#### 6. Statusanzeige und Fehlerbehebung

Statusanzeige	Status	Fehlerbehebung
Grün	Papier im Papierhalter. Drucker ist eingeschaltet und befindet sich im normalen Betriebs-zustand.	/
Rot mit zwei Signaltönen	Oberteil nicht geschlossen; Papierhalter leer.	Prüfen Sie, ob die Oberseite des Druckers richtig geschlossen ist; Prüfen Sie, ob das Papier richtig eingelegt ist.

#### 7. Handlungsanweisung bei Papierstau

Schalten Sie den Drucker aus und öffnen Sie das Oberteil. Ziehen Sie das gestaute Papier vorsichtig heraus und setzen Sie erneut Papier ein.

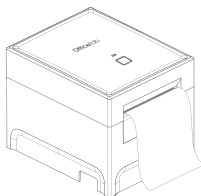

**Warnung:** Lassen Sie den Drucker erst abkühlen. Der Drucker kann sehr heiß werden. Verbrennungsgefahr!

#### Hinweis:

Wenn es zu Papierstau kommt, kann dies an Kleberrückständen oder Schmutz auf dem Druckkopf liegen.

Wenn sich Kleberrückstände oder Schmutz auf dem Druckkopf befinden, reinigen Sie den Druckkopf mit dem mitgelieferten Alkohol-Reinigungsstift. Sie können mit dem Drucken fortfahren, sobald der Alkohol getrocknet ist.

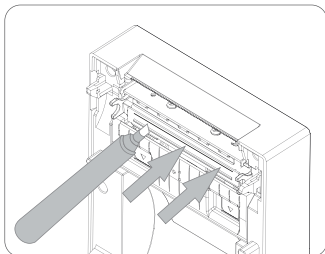

DE

### 8. FAQ:

#### Q: Der Drucker funktioniert nicht

Fehler	Mögliche Ursache	Lösung
Die Statusanzeige leuchtet nicht, und der Drucker funktioniert nicht	Drucker von der Stromversorgung getrennt	Schließen Sie den Drucker an die Stromversorgung an
	Drucker nicht eingeschaltet	Schalten Sie den Schalter des Druckers auf EIN
	Die Schaltplatine ist beschädigt	Bitte kontaktieren Sie uns per E-Mail an <a href="mailto:support@inateck.com">support@inateck.com</a>

#### Q : Probleme im Druckprozess

Fehler	Mögliche Ursache	Lösungen
Undeutlicher oder verschmierter Druck	Papierrolle ist falsch eingelegt	Prüfen Sie, ob das Papier richtig eingelegt ist
	Druckdichte zu niedrig eingestellt	Benutzer-Tools befinden sich auf dem mitgelieferten USB-Stick. In den darauf enthaltenen Tools befinden sich Einstellungen für die Druckdichte
	Papier entspricht nicht den Anforderungen	Bitte verwenden Sie Officelab-Thermopapier oder ein anderes empfohlenes Thermopapier
	Verschmutzter Druckkopf oder verschmutzte Gummivalze	Druckkopf oder Gummivalze reinigen

### 9. Kontakt

Wenn Sie Fragen zum Officelab PR02002 haben, können Sie sich gerne per E-Mail an [support@inateck.com](mailto:support@inateck.com) wenden. Wir helfen Ihnen gern.

Il s'agit d'une version brève du mode d'emploi de PR02002. Pour plus d'information sur l'installation du pilote aux systèmes Windows et Mac OS, les étapes d'impression à l'aide d'un câble série ou Ethernet, les étapes d'impression du LOGO NV, ou l'emploi des outils d'utilisateurs (pour le système Windows uniquement), veuillez consulter le disque flash générique USB dans lequel vous trouverez l'illustration de vidéo détaillée et le guide d'utilisateur.

Si vous avez un problème ou une suggestion avec notre produit, veuillez nous contacter via [support@inateck.com](mailto:support@inateck.com)

### Conseils de sécurité

1. Ne pas brancher/débrancher le câble d'alimentation à/de la source d'alimentation lorsque l'interrupteur de l'imprimante est basculé sur « ON ». 
2. Ne pas utiliser ou stocker l'imprimante dans des endroits soumis à une température élevée, à une humidité élevée ou à une pollution grave .
3. Connecter l'adaptateur secteur de l'imprimante à une prise de terre appropriée. Éviter d'utiliser la même prise avec des moteurs ou d'autres équipements de grande consommation d'énergie, qui peuvent provoquer des fluctuations de tensions d'alimentation.
4. Si l'imprimante n'est pas utilisée pour une longue période, veuillez débrancher l'adaptateur secteur .
5. Il y a un cutter sur le capot supérieur de l'imprimante. Lorsque vous ouvrez le dessus, assurez-vous qu'il est complètement ouvert afin que le cutter ne blesse pas votre doigt. Vous pouvez vous référer aux images ci-dessous :

Ouverture incomplète

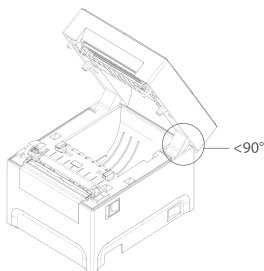

Ouverture complète

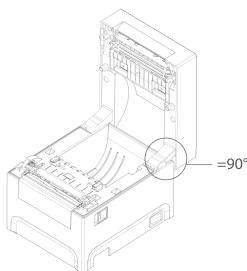

## 1. Pièces du colis

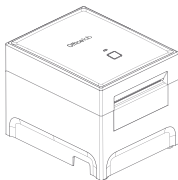

Imprimante

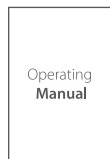

Mode d'Emploi

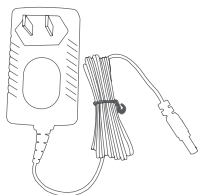

Adaptateur d'Alimentation

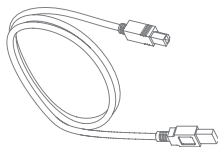

Câble USB

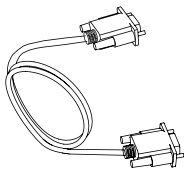

Câble série

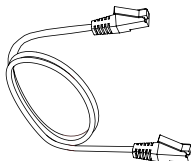

Câble Ethernet



Clé USB



Stylo de Nettoyage



Papier de reçu thermique



Mode d'Emploi Papier Thermique  
Directement Stylo de Nettoyage

## 2. Illustration des pièces principales

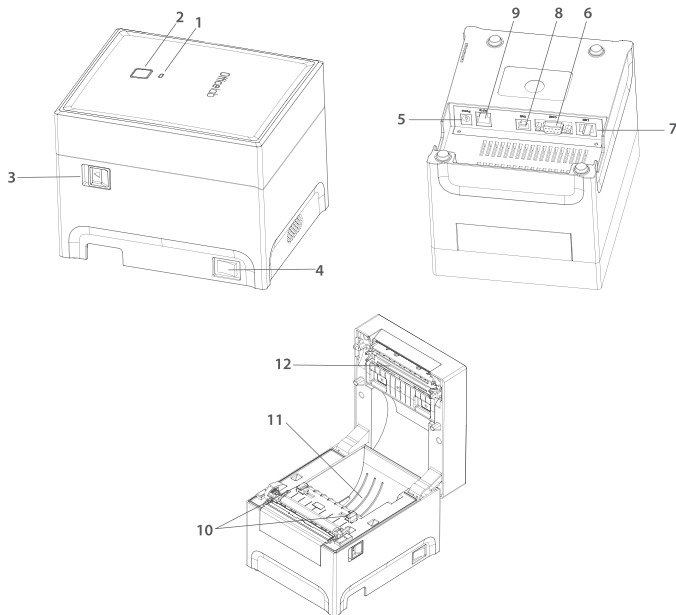

- 1) Indicateur
- 2) Bouton Avancer
- 3) Bouton d'ouverture
- 4) Interrupteur d'alimentation
- 5) Port d'alimentation
- 6) Interface du port série (RS-232)
- 7) Interface de réseau (RJ-45)
- 8) Port d'USB
- 9) Port de caisse (RJ-12)
- 10) Dispositif de transport de papier mobile
- 11) Porte-papier
- 12) Tête d'impression

### Note: Interrupteur d'Alimentation

Appuyer sur l'interrupteur d'alimentation à «I» pour allumer l'imprimante.



Appuyer sur l'interrupteur d'alimentation à «O» pour éteindre l'imprimante.



Veuillez utiliser l'adaptateur d'alimentation original accompagné dans le paquet afin d'éviter un résultat d'impression insatisfaisant ou des dommages à l'imprimante.

### 3. Comment utiliser

3.1 Assurez-vous que l'interrupteur est à l'état "Off", puis connecter l'imprimante à la source d'alimentation.

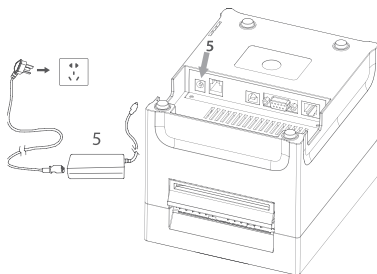

3.2 Connecter les câbles

3.2.1 Utiliser un câble USB pour connecter le port USB de l'imprimante à un ordinateur ;

3.2.2 Brancher le câble série dans le port série

3.2.3 Brancher le câble Ethernet RJ45 dans l'interface réseau ;

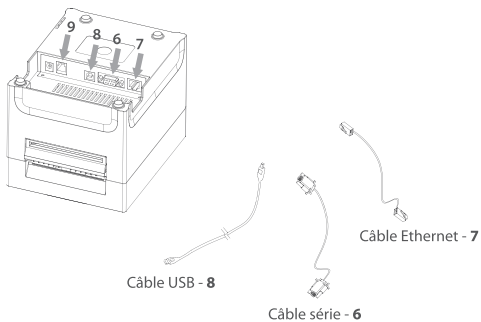

3.3 Basculer l'interrupteur d'alimentation sur "I" pour allumer l'imprimante ;

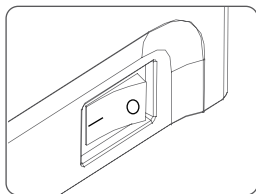

3.4 Appuyer sur le bouton d'ouverture sur le dessus pour faire apparaître le compartiment papier interne ; installer un rouleau de papier, déplacer la pince d'entrée du papier pour serrer le papier ;

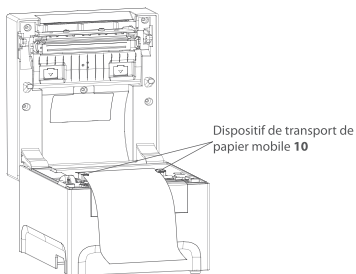
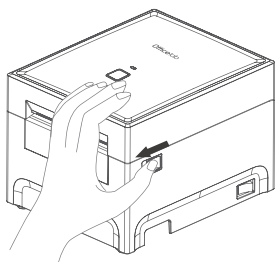

## 4. Installation du pilote

Dans le disque flash USB, vous trouverez le pilote et son instruction d'installation (pour Mac et Windows). Ils sont également disponibles sur le site officiel [www.inateck.com](http://www.inateck.com).

## 5. Imprimer la page d'autotest

Lorsque l'imprimante est éteinte, appuyer longuement sur le bouton d'avancer et puis allumer l'imprimante. Ne pas lâcher le bouton jusqu'à ce que l'imprimante soit allumée pendant 3 secondes. L'imprimante enverra alors une page d'autotest.

## 6. États de l'indicateur et dépannage

Indicateur	États	Dépannage
Vert	Il y a du papier dans le porte-papier. L'imprimante est allumée et en état de travail normal.	/
Rouge avec deux alerte sonores	Le couvercle n'est pas correctement fermé ; le porte-papier est vide.	Vérifier si le couvercle est correctement fermé ; vérifier si le papier est correctement installé.

## 7. Éliminer le bouchage de papier

Éteindre l'imprimante et ouvrir le dessus. Retirer le papier coincé dans l'entrée et installer un nouveau papier.

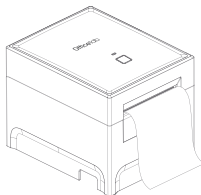

**⚠ Avertissement :** faire attention aux risques de brûlure. La température de l'imprimante est élevée lorsqu'elle vient de cesser de fonctionner.

**Note :**

Si le papier est coincé, veuillez vérifier s'il y a des résidus d'adhésif ou de saleté sur la tête d'impression. Si tel est le cas, veuillez les essuyer avec le stylo de nettoyage à l'alcool inclus dans l'emballage. L'imprimante peut reprendre son travail lorsque l'alcool est séché.

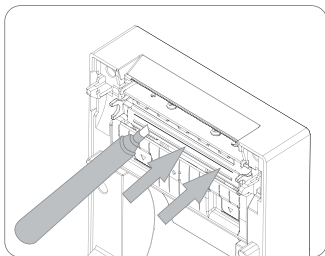

## 8. FAQ:

FR

Q: L'imprimante ne travaille pas

Panne	Cause possible	Solution
L'indicateur ne s'allume pas et l'imprimante ne fonctionne pas	L'imprimante est déconnectée de l'alimentation	Connecter l'imprimante à une source d'alimentation
	L'imprimante n'est pas allumée	Basculer l'interrupteur de l'imprimante sur ON
	Le circuit imprimé est endommagé	N'hésitez pas à nous envoyer un e-mail à support@inateck.com

Q : Problèmes lors du processus d'impression

Panne	Cause possible	Solution
Impression peu claire ou tachée	Le rouleau de papier n'est pas correctement installé	Vérifier si le papier est installé correctement
	La densité d'impression est faible.	Les outils d'utilisateurs sont inclus dans le disque générique flash USB. Vous pouvez installer les outils pour ajuster la densité d'impression
	Le papier ne répond pas aux exigences	Veuillez utiliser le papier de reçu thermique d'Officelab ou des papiers de reçu thermiques recommandés
	La tête d'impression ou le rouleau d'impression est sale	Nettoyer la tête d'impression ou le rouleau d'impression

## 9. Nous contacter

N'hésitez pas à nous envoyer un e-mail à support@inateck.com si vous avez des questions concernant Officelab PR02002. Nous sommes toujours à votre disposition



Questa è una versione breve del manuale di istruzioni. Per ulteriori informazioni sull'installazione del driver (sistemi Mac OS e Windows), sulla stampa mediante cavo seriale o Ethernet, sulla stampa NV LOGO o su come utilizzare gli strumenti utente (solo per sistemi Windows), fare riferimento al disco flash USB. Il disco contiene dettagliate video-istruzioni ed una guida all'uso.

In caso di problemi o suggerimenti per il nostro prodotto, la preghiamo di contattarci all'indirizzo: support@inateck.com.

### Norme sulla sicurezza

1. Non collegare o scollegare il cavo dalla fonte di alimentazione quando l'interruttore della stampante è impostato su "On" 
2. Non utilizzare o conservare la stampante in luoghi ad elevata temperatura, elevata umidità o grave inquinamento.
3. Collegare l'alimentatore della stampante ad una presa con messa a terra adeguata. Evitare l'utilizzo della stessa presa con motori o altre apparecchiature ad alto consumo energetico; questo potrebbe causare fluttuazioni e sbalzi di tensione.
4. Se la stampante non viene utilizzata per un lungo periodo, scollegare l'alimentatore.
5. Sul coperchio superiore della stampante è presente una taglierina. Nell'aprire la parte superiore, assicurarsi che questa venga aperta completamente per evitare che la taglierina ferisca le dita. Si faccia riferimento alle immagini sotto:

Non aperta completamente

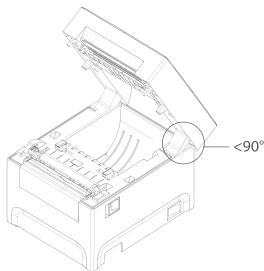

Aperta completamente

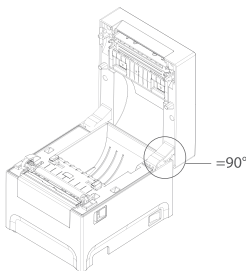

## 1. La confezione include

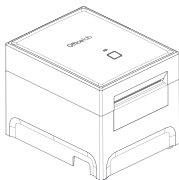

Stampante

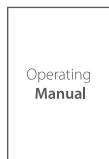

Manuale di Istruzioni

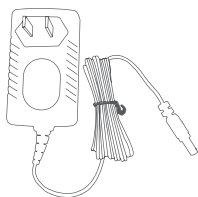

Stampante

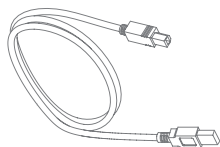

Cavo USB

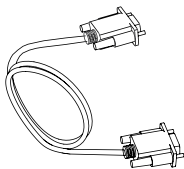

Cavo seriale

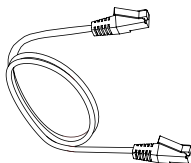

Cavo Ethernet

IT



Chiavetta USB



Cleaning Pen



Carta termica per scontrini



Manuale di Istruzioni per Carta Termica a riscaldamento diretto & Cleaning Pen

## 2. Illustrazione parti principali

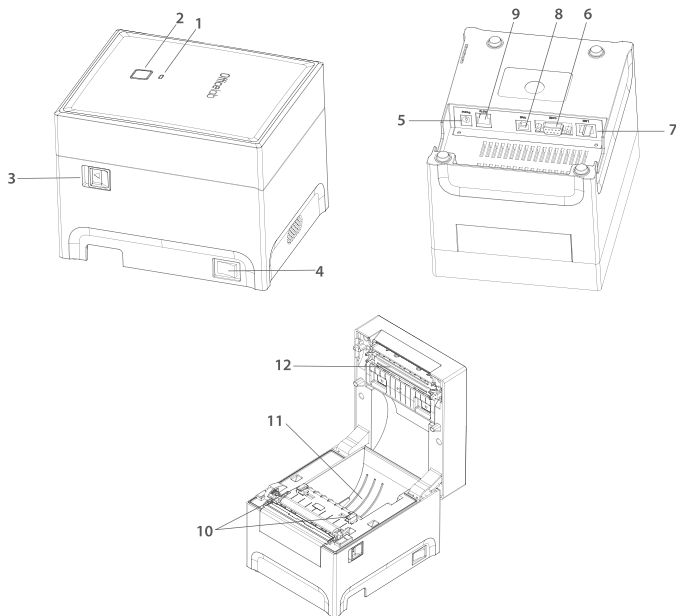

- 1) Indicatore
- 2) Pulsante di avanzamento carta
- 3) Pulsante d'apertura
- 4) Interruttore di accensione
- 5) Porta di alimentazione
- 6) Interfaccia porta seriale (RS-232)
- 7) Interfaccia di rete (RJ-45)
- 8) Porta USB
- 9) Porta Cashbox (RJ-12)
- 10) Dispositivo mobile di convoglio carta
- 11) Supporto carta
- 12) Testina di stampa

### Nota: Interruttore di accensione

Imposta il pulsante su "I" per accendere la stampante.



Imposta il pulsante su "O" per spegnere la stampante.

Si prega di utilizzare l'alimentatore originale incluso nella confezione, al fine di evitare risultati di stampa poco soddisfacenti, oppure danni alla stampante.

### 3. Modalità di utilizzo

3.1 Assicurarsi che l'interruttore sia impostato su "Off", quindi connettere la stampante alla fonte di alimentazione.

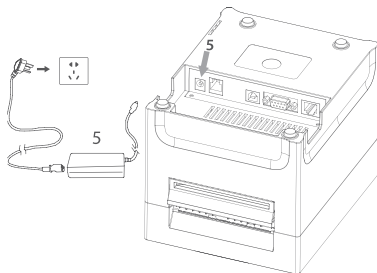

#### 3.2 Connessione cavi

3.2.1 Utilizza un cavo USB per connettere la porta USB della stampante al computer;

3.2.2 Collega il cavo seriale alla porta seriale;

3.2.3 Collega il cavo Ethernet RJ45 all'interfaccia di rete;

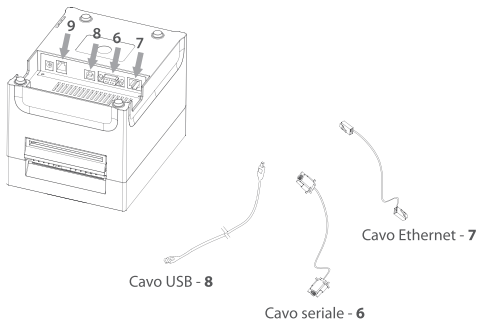

3.3 Imposta l'interruttore su "I" per accendere la stampante;

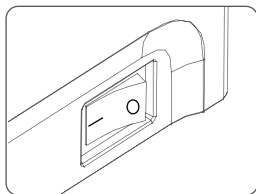

3.4 Premi il pulsante di apertura per rivelare lo scomparto interno della carta; installa un rotolo di carta, sposta la clip di ingresso per bloccare la carta;

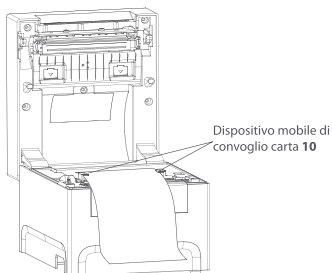
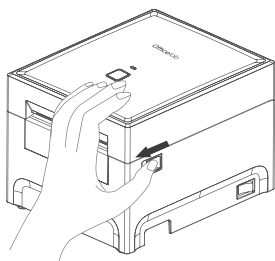

#### 4. Installazione driver

Nell'unità flash USB sono presenti driver e guida all'installazione (sia per Mac che per Windows). Questi ultimi sono disponibili anche sul sito ufficiale: [www.inateck.com](http://www.inateck.com).

#### 5. Stampa la pagina di prova

Quando la stampante è spenta, tenere premuto il pulsante di avanzamento carta, quindi accendere la stampante. Non lasciare il pulsante finché la stampante non è accesa per 3 secondi. A quel punto la stampante invierà una pagina di prova.

#### 6. Stato dell'indicatore e risoluzione problemi

Indicatore	Stato	Risoluzione problema
Verde	La carta è presente nell'apposito supporto. La stampante è accesa ed è in condizioni di lavoro normali.	/
Rosso con due segnali acustici	Coperchio non chiuso; Supporto per la carta vuoto.	Verifica che la parte superiore della stampante sia chiusa correttamente; Verifica che la carta sia installata correttamente.

#### 7. Trattamento per carta bloccata / inceppata

Spegni la stampante e apri il coperchio superiore. Estrai la carta inceppata dallo scomparto ed inserisci nuova carta.

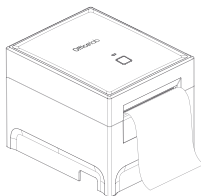

 **Avvertenza:** Attenzione alle possibili scottature. La temperatura della stampante è piuttosto alta quando smette di funzionare.

**Nota:**

Se la carta si inceppa, si prega di controllare che nella testina di stampa non siano presenti tracce di adesivo o sporczia. In tal caso, rimuovere i residui con la penna pulente all'alcol inclusa nella confezione. La stampante può tornare in funzione quando l'alcol si è asciugato.

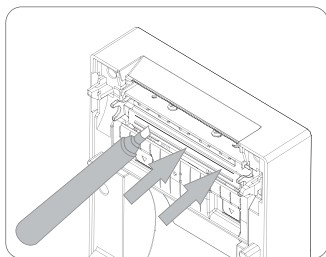
**8. FAQ:****Q: La stampante non funziona**

Problema	Possibile causa	Soluzione
L'indicatore non si accende, e la stampante non funziona	La stampante è scollegata dall'alimentazione	Collega la stampante all'alimentazione
	La stampante non è accesa	Imposta l'interruttore della stampante su "On"
	La scheda di circuito è danneggiata	Contattaci via mail all'indirizzo: support@inateck.com

**Q: Problemi nel processo di stampa**

Problema	Possibile causa	Soluzione
Stampa poco chiara o con sbavature	Il rotolo della carta non è installato correttamente	Verifica che la carta sia caricata correttamente
	È impostata una bassa densità di stampa	Gli strumenti utente sono inclusi nella confezione del disco flash USB. È possibile installare gli strumenti per regolare la densità di stampa
	Il tipo di carta non è adeguato	Utilizza carta termica per scontrini Officelab o altra carta termica consigliata
	Testina o rullo gommato di stampa sporchi	Pulisci la testina o il rullo gommato di stampa

**9. Contattaci**

Non esiti a contattarci via mail: support@inateck.com per qualsiasi domanda riguardante Officelab PR02002. Saremo felici di fornirle assistenza.

Esta es una versión resumida del manual de instrucciones de la PR02002. Para obtener más información sobre la instalación del controlador en los sistemas Mac OS y Windows, los pasos de impresión mediante el uso de un cable de serie o Ethernet, los pasos para imprimir el LOGO NV, o sobre cómo utilizar las herramientas de usuario (solo para el sistema Windows), por favor, consulte el disco flash genérico USB con una ilustración en video detallada y la guía de usuario.

Si tiene algún problema o sugerencia con nuestro producto, póngase en contacto con nosotros a través de [support@inateck.com](mailto:support@inateck.com).

### Normas de seguridad

1. No enchufe/desenchufe el cable de alimentación a/desde la fuente de alimentación cuando el interruptor de la impresora esté en "ON": 
2. No utilice ni almacene la impresora en lugares con alta temperatura, alta humedad o fuerte contaminación.
3. Conecte el adaptador de corriente de la impresora a una toma de corriente adecuada con conexión a tierra. Y evite utilizar el mismo enchufe con motores u otros equipos de gran consumo de energía que puedan provocar fluctuaciones de tensión.
4. Si la impresora no se va a utilizar durante un largo periodo de tiempo, desenchufe el adaptador de corriente.
5. Hay un cortador en la tapa superior de la impresora. Cuando abra la tapa, por favor, asegúrese de que está completamente abierta para que el cortador no le haga daño a su dedo. Puede consultar las imágenes de abajo:

No completamente abierta

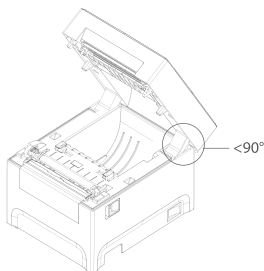

Completamente abierta

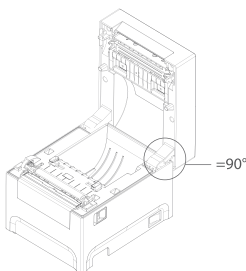

## 1. Contenido del paquete



Impresora



Manual de instrucciones

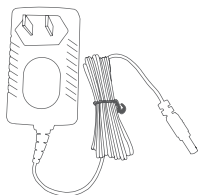

Adaptador de alimentación

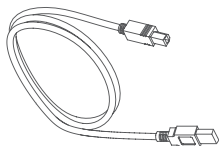

Cable USB

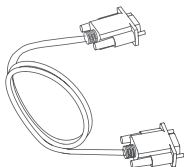

Cable serial

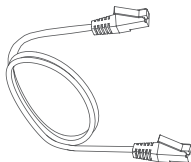

Cable Ethernet



USB-pošmemorilo



Bolígrafo de limpieza



Papel de recibo térmico



Manual de instrucciones del papel térmico de calentamiento directo y de la pluma de limpieza



## 2. Ilustración de los componentes principales

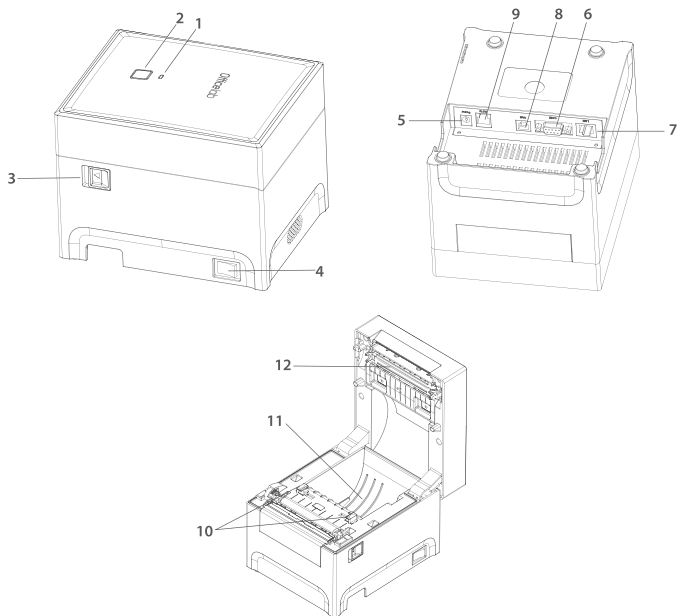

- 1) Indicador
- 2) Botón de forma de alimentación
- 3) Botón de apertura
- 4) Interruptor
- 5) Puerto de alimentación
- 6) Interfaz de puerto serie (RS-232)
- 7) Interfaz de red (RJ-45)
- 8) Puerto USB
- 9) Puerto de caja (RJ-12)
- 10) Dispositivo móvil de transporte de papel
- 11) Soporte para el papel
- 12) Cabezal de impresión

### Nota: Interruptor

Coloque el interruptor de encendido en "I" para prender la impresora.



Coloque el interruptor de encendido en "O" para prender la impresora.



Por favor, use el adaptador de corriente original que viene incluido en el paquete para evitar resultado de impresión insatisfactorios o daños en la impresora.

### 3. Modo de uso

3.1 Asegúrese que el interruptor está en "Off" y luego conecte la impresora a la fuente de corriente.

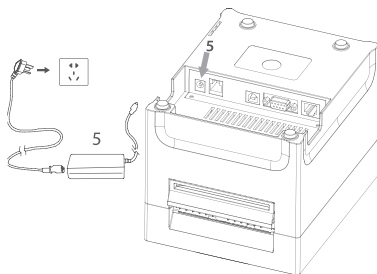

#### 3.2 Cable de conexión

3.2.1 Utilice un cable USB para conectar el puerto USB de la impresora a un ordenador;

3.2.2 Conecte el cable de serie en el puerto serie;

3.2.3 Conecte el cable Ethernet RJ45 en la interfaz de red;

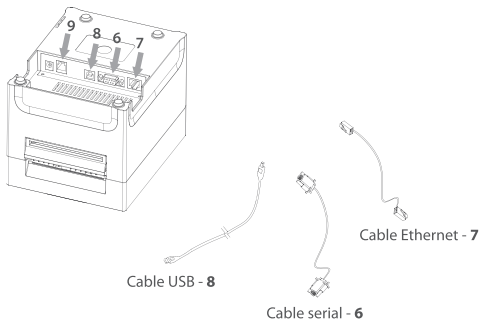

3.3 Coloque el interruptor de encendido en "I" para encender la impresora;

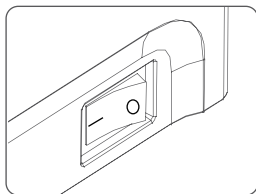

3.4 Presione el botón de apertura superior para revelar el compartimiento interno de papel; instale un rollo de papel, mueva el clip de entrada de papel para sujetar el papel;

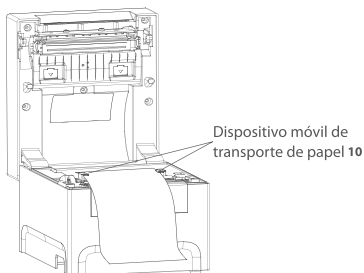
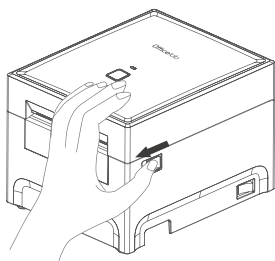

#### 4. Instalación del controlador

En la memoria USB, los usuarios pueden encontrar la unidad y sus instrucciones de instalación (tanto para Mac como para Windows). También están disponibles en el sitio oficial [www.inateck.com](http://www.inateck.com).

#### 5. Imprimir la página de autocomprobación

Cuando la impresora esté apagada, presione prolongadamente el botón de alimentación de formularios y luego encienda la impresora. No suelte el botón hasta que la impresora esté encendida durante 3 segundos. La impresora enviará entonces una página de autocomprobación.

#### 6. Estado del indicador y solución de problemas

Indicador	Estado	Solución de problemas
Verde	Hay papel en el soporte del papel. La impresora está encendida y en estado de funcionamiento normal.	/
Rojo con dos pitidos de alerta	La parte superior no está cerrada; el portapapeles está vacío.	Compruebe si la parte superior de la impresora está bien cerrada. Compruebe si el papel está bien instalado.

#### 7. Procedimiento para arreglar el papel trabado/atascado

Apague la impresora y abra la tapa. Extraiga el papel trabado/atascado de la entrada e instale uno nuevo.

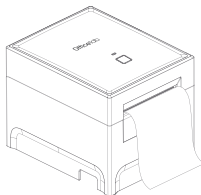

**⚠ Atención:** Tenga cuidado con posibles escaldaduras. La temperatura de la impresora es alta apenas termina de funcionar.

**Nota:**

Si el papel se atasca, por favor verifique si hay algún residuo de adhesivo o polvo en el cabezal de la impresora. Si así es, limpie con el marcador de limpieza con alcohol incluida en el paquete. La impresora puede volver a usarse una vez el alcohol se haya secado.

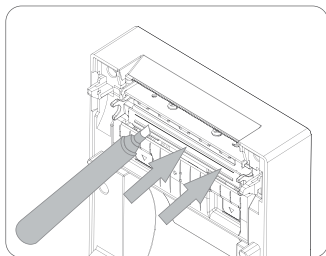
**8. FAQ:****Q: The printer refuses to work**

Falla	Posible causa	Solución
El indicador no se enciende y la impresora no funciona	La impresora está desconectada de la corriente	Conecte la impresora a la corriente eléctrica
	La impresora no está encendida	Ponga el interruptor de la impresora en ON
	La placa de circuito está dañada	No dude en enviarnos un correo electrónico a support@inateck.com

**Q : Problemas en el proceso de impresión**

Falla	Posible causa	Solución
Impresión poco nítida o borrosa	El rollo de papel está mal instalado	Compruebe si el papel está instalado correctamente
	Ajuste de baja densidad de impresión	Las herramientas de usuario se incluyen en el disco flash genérico USB que viene en el paquete. Puede instalar las herramientas para ajustar la densidad de impresión.
	El papel no cumple los requisitos	Utilice el papel térmico para recibos de Officelab o un papel térmico para recibos recomendado
	Cabezal de impresión o rodillo de goma de impresión sucios	Limpie el cabezal de impresión o el rodillo de goma de impresión

**9. Contáctenos**

No dude en enviar un correo electrónico a support@inateck.com si tiene alguna pregunta sobre Officelab PRO2002 . Estaremos encantados de ayudarle.



## Contact Information

### USA

Tel.: +1 909-698-7018

Phone hours: Weekdays 9 AM to 5 PM (EST)

Email: [support@inateck.com](mailto:support@inateck.com)

Web: [www.inateck.com](http://www.inateck.com)

Addr.: Inateck Technology Inc, 2078 Francis St., Unit 14-02, Ontario,  
San Bernardino, CA 91761

### Germany

Tel.: +49 341-51998410 Fax: +49 34151998413

Phone hours: Weekdays 9 AM-5 PM (CET)

Email: [support@inateck.com](mailto:support@inateck.com)

Web: <http://www.inateck.com/de/>

Addr.: F&M Technology GmbH, Fraunhoferstraße 7, 04178 Leipzig

### Company of License Holder

F&M Technology GmbH

Fraunhoferstraße 7, 04178 Leipzig

Tel.: +49 341-51998410

### Manufacturer Information

ShenZhen LiCheng Technology Co., Ltd.

Ad.: Rm. 2507, Bldg. 11, TianAn Cloud Park, Bantian Street, Longgang District, Shenzhen, Guangdong, China

Tel: +86 755-23484029

### Made in China