

### Danger and Warning

- DO NOT shine light directly into eyes. This may cause temporary blindness and/or cause permanent damage to the eyes.
- DO NOT cover the light head when the flashlight is on or place the light head on the ground. The heat dispersion of the light may cause damage to the flashlight itself or even result in burning other objects.
- Keep out of reach of children.
- DO NOT activate turbo mode repeatedly under high temperature to prevent the flashlight body from overheating and hurting the user's hand.

### Inside the box

- 1\*SPERAS TH11
- 1\*18650 3100mah Lithium Battery
- 1\*USB-C charging cable
- 1\*Scope Mount
- 1\*Red LED Module (OSRAM LED)
- 1\*Green LED Module (OSRAM LED)
- 1\*USB-C remote pressure Switch
- 2\*Extra O-rings
- 1\*User manual

### Specification

FL1 STANDARD	White High performance S1	Red Osram LED	Green Osram LED
Flood Output	600m~20m	200m~5m	600m~20m
Flood Max distance	128m	62m	131m
Focus Output	400m~10m	100m~3m	400m~10m
Focus Max distance	894m	602m	1204m
Running Time	2.4h~48h	2.4h~48h	2.4h~48h
Beam Intensity	200,000cd	90,500cd	362,500cd
Lens	50mm PMMA Optical lens		
Battery Source	18650 lithium battery*1		
Charging Time	4.5h		
Impact Distance	1.5m		
Waterproof	IP68 (water 2m)		
Material	Aerospace 6061 Aluminum Alloy		
Finish	Premium Hard-anodizing Black		
Dimension	Flood: 155(L)Length*54(Head)*25.4(Tube)mm Focus: 177(L)Length*54(Head)*25.4(Tube)mm		
Net Weight	216g(不含Battery)		

Note: The above data has been measured in accordance with international flashlight testing standards ANSI/NEMA FL1 using a SPERAS 3.7V/3100mAh 18650 lithium battery under laboratory conditions.

### Product Overview

The SPERAS TH11 is one of the NO.1 professional and powerful hunting light in the market with 50mm Optical lens. Equipped with advanced structure design, driver design and high performance LED, the white light of TH11 can reach to max 600m output, 894m max beam distance; the green light can reach to max 600m output, 1204m; the red light can reach to max 200m output, 602m max beam distance. Its multifunctional type-C port supports type C charging, type C

### Battery Installation

Before the first use, please remove the insulating film of battery in the flashlight. And if the battery needs to be changed, make sure the positive polarity side of the battery faces toward the direction of the flashlight head (the side of the LED).

### Operating Instructions

- Flood Beam/Focus Beam**  
Hold the head of TH11, and twist the tube or tail to adjust the beam to go from a flood beam to the focus beam.
- ON/OFF**  
In the OFF state, click the switch to turn on (enter the memory brightness); another click to turn off the flashlight.  
In the OFF state, press and hold the tail switch for 0.3s to enter the memory brightness, release to turn off the light.
- Change Brightness Level**  
In the ON state, twist the switch left to dim the beam and right to increase the brightness. The adjustable brightness ranges various from 3%~100%.

### Charging

The TH11 supports 5V/1A charging. Insert the cable to the type-C port and connect the adapter to charge. When charging, the indicator will display as follows:  
 ■ Green: full charged  
 ■ Red: Busy charging  
 ■ The full charging time is about 4.5H.  
 ■ Note: During charging, TH11 can not be turned on.

### Power Indication

When the flashlight is turned on, the LED indicator beside the USB-C charging port will automatically monitor the power for 5 seconds. Power indicator will display one of the following:  
 Green: > 30%  
 Red: < 30%

### How to use the Remote Pressure Switch

**S1: Enter the High mode/Momentary ON/Increase Brightness**  
In the OFF state, click the S1 button, the light will turn on at 100% brightness. Click S2 button can turn off the light.  
In the OFF state, press and hold the S1 button to momentary ON (100% brightness), release to turn off.  
In the ON state, press and hold the S1 button to increase brightness till to 100% brightness.

**S2: OFF/Flash**  
In the OFF state, click the S2 button to turn on (memory brightness); click again to turn off.  
In the OFF state, press and hold the S2 button for 0.3s to momentary on; release to turn the light off.  
In the ON state, click S2 button to turn off the light.

**S3: Decrease Brightness**  
In the ON state, press and hold the S3 button to decrease the brightness till to 3% brightness.

### How to Change the LED Module

- Remove the head of TH11
- Twist down the center part
- Twist down the LED module and twist on the new LED module.
- Screw on the head of TH11 to start to use the light.

### Usage and Maintenance

- Please fully charge the battery before initial use.
- To maintain the waterproof rating, please lubricate the O-ring with silicone safe lubricant and replace broken O-rings as soon as possible.
- If the light will not be used for a long period or when transported, please unscrew the tail cap and remove the battery to break the circuit.

### Warranty

- The product is provided with a 5-year warranty. Any non-artificial damage, please contact the SPERAS after-sales department.
- The warranty does not cover normal wear and tear, modifications, misuse, disintegrations, negligence, accidents, improper maintenance or repairs by anyone other than an authorized retailer or SPERAS itself.

### Beyond Warranty

Free warranty DO NOT cover any damage or failure caused by:  
 ■ Normal wear up  
 ■ Damages caused by disassembling, modifying the flashlight  
 ■ Damages caused by rough operation or misuse  
 ■ Improper maintenance or repairs by anyone other than an authorized retailer or SPERAS itself

**Shenzhen Speras Lighting Co., Ltd**  
 Add: 4F, Building G, Gangshan Innovation Park, Huangning Road, Dalang Street, Longhua District, Shenzhen, China, 518109  
 Tel: +86-755-2107-2597  
 Email: info@speraslight.com  
 Website: www.speraslight.com

### Warranty Card

Product Model No.: \_\_\_\_\_  
 Serial No.: \_\_\_\_\_  
 Date of Purchase: \_\_\_\_\_  
 Dealer Signature / Stamp: \_\_\_\_\_

**Thank you for choosing SPERAS.**  
 The SPERAS flashlight is covered by a 5-year warranty from the date of purchase. Please ask the dealer/distributor to fulfill the date of purchase and sign/stamp the warranty card after purchase.  
 Contact the dealer/distributor of SPERAS flashlight first if help needed.

**Notice:** The warranty covers manufacturer defects solely and becomes invalid if the flashlight is subjected to work by an unauthorized party.

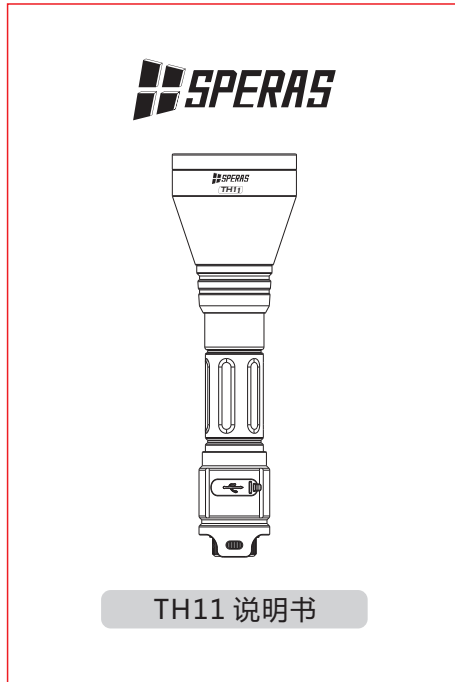

### 风险提示

- 首次使用, 请仔细阅读说明书。
- 请勿将光线直射眼睛, 这可能会导致暂时失明或对眼睛造成永久性损伤。
- 请勿在手电筒开启时遮盖灯头, 或将灯头放在地上。光的热扩散可能会导致手电筒本身的损坏, 甚至导致其他物体燃烧。
- 请在儿童接触不到的地方。
- 请勿在高温下反复开启极亮模式, 以防止手电筒过热伤手。
- 请使用配套电池。

### 包装包含

- 1\*TH11手电筒
- 1\*18650 3100mah 充电电池
- 1\*USB-C 充电线
- 1\*瞄准镜夹
- 1\*红光灯罩 / 1\*绿光灯罩
- 1\*USB-C 远程开关
- 2\*备用防水圈
- 1\*说明书

### 产品参数

ANSI标准参数	白光高性能S1 LED	红光 Osram LED	绿光 Osram LED
亮度 (烛光)	600m~20m	200m~5m	600m~20m
射程 (英尺)	128m	62m	131m
亮度 (英尺)	400m~10m	100m~3m	400m~10m
射程 (英尺)	894m	602m	1204m
续航时长	2.4h~48h	2.4h~48h	2.4h~48h
光通量	200,000cd	90,500cd	362,500cd
镜片	50mm PMMA 透镜		
电池	18650 锂电池*1		
充电时长	4.5h		
防水等级	IP68 (水下2m)		
材料	航空级铝 6061 铝合金		
表面处理	硬氧化/黑色		
尺寸	白光状态: 145 (筒)*54 (头)*25.4 (筒身直径)mm 白光状态: 177 (筒)*54 (头)*25.4 (筒身直径)mm		
净重	216g (不含电池)		

注: 以上数据是根据国际手电筒测试标准ANSI/NEMA FL1使用SPERAS 3.7V / 3100mAh 18650锂电池在实验室条件下测得。

### 产品简介

SPERAS TH11, 配备 50mm 光学透镜, 是市场上专业且功能强大的优秀狩猎灯之一。搭配先进的结构设计、驱动设计以及高性能LED, TH11的白光可以达到最大600m输出; 最大光束距离894m; 绿光可达最大600m输出, 1204m; 红光可以达到最大200m输出, 最大光束距离602m。其多功能Type-C接口支持Type C充电、Type C远程压力开关,

让用户使用起来更轻松、有效。尾部旋转调光器, 操作无声且亮度调节顺畅。TH11支持可调焦功能, 用户可根据需求选择光束来瞄准目标。TH11是猎人、搜索或救援或其他户外照明需求的理想手电筒。

### 电池安装

首次使用前, 请将手电筒内的电池绝缘膜取出。如果需要更换电池, 请确保电池的正负极朝向手电筒头的方向 (LED 的一侧)。

### 操作说明

- 泛光光束/聚焦光束**  
握住 TH11 的头, 转动筒身或尾部以调整光束, 泛光光束或聚焦光束或任何中间状态。
- 打开/关闭**  
在关闭状态下, 单击尾部开关0.3s进入记忆亮度档位; 再次单击, 关闭手电筒。
- 调整亮度**  
在开启状态下, 向左转动开关可使光束变暗, 向右转动可增加亮度。可调节亮度范围为3%~100%。

### 如何充电

TH11 支持 5V/1A 充电。将数据线插入 type-C 端口并连接适配器进行充电。充电时, 指示灯显示如下:  
 绿灯: 充满电  
 红灯: 充电中  
 充满时长约4.5小时。  
 注意: 充电过程中, TH11无法使用。

### 电量指示

手电筒打开时, USB-C充电口旁边的LED指示灯会自动监测电量并亮起5秒, 指示电量如下:  
 绿灯: > 30%  
 红灯: < 30%

### 如何使用远程开关

**S1: 进入高亮/瞬时开启/增加亮度**  
在关闭状态下, 单击S1按键, 打开手电筒 (100%亮度)。单击S2按键, 手电筒关闭。  
在关闭状态下, 按住S1按键, 手电筒闪亮 (100%亮度), 松开, 手电筒关闭。  
在打开状态下, 按住S1键可增加亮度直至最高亮度, 便无法继续增加。

**S2: 打开/关闭**  
在关闭状态下, 单击S2按键, 打开手电筒 (进入记忆亮度档位); 再次单击, 手电筒关闭。  
在关闭状态下, 按住S2按键, 手电筒闪亮; 松开, 手电筒关闭。  
在打开状态下, 单击S2按键, 关闭手电筒。

**S3: 降低亮度**  
在打开状态下, 按住S3按键可降低亮度直至最低亮度, 便无法继续降低。

### 如何更换 LED 灯胆

- 旋转取下TH11的灯头组件
- 旋转取出灯胆
- 更换上新灯胆
- 旋紧灯头即可使用手电筒。

### 使用与维护

- 手电在使用过程中, 手电表面温度在60度以下属于正常情况, 请放心使用。
- 首次使用前请给电池充满电。
- 每半年用棉签清理手电筒并涂上润滑油。
- 为达到最佳防水性能, 请定期检查防水O圈的完整性, 并请适量涂抹润滑油于防水圈上以延长其使用寿命。如O圈损坏, 请及时更换原厂O圈以确保您所使用的产品的优异防水性能。
- 长时间不使用手电筒时, 请将电池取出, 并妥善存放于阴凉干燥处。

### 保修条款

- 30天包退换: 本产品自售出之日起30天内, 在正常使用情况下, 出现产品质量问题, 客户可选择维修服务或者更换同型号同规格的新品。如同型号同规格的产品停止生产或因其他原因不能在合理时间内安排更换, 则调换不低于原产品性能的同品牌产品。
- 5年免费保修: 本产品自售出之日起5年内, 用户在正常使用情况下, 出现产品质量问题, 可享受免费维修服务; 因使用不当或擅自改装、维修而引起的产品缺陷、损坏, 不在保修范围内。
- 终身有限保修: 在超过5年免费保修期后, SPERAS将提供有偿维修服务, 费用以实际更换材料费用为准, 不收人工费用。
- 请先联系您的经销商: 请提供您购买时SPERAS保修卡、购买发票、收据或其卖家的证明, 直接联系您的经销商进行售后服务, SPERAS将为经销商提供技术支持。

### 不在保修范围

免费保修不包括由以下原因引起的任何损坏或故障:  
 ■ 正常使用磨损。  
 ■ 因拆卸、改装手电筒而造成的损坏。  
 ■ 因暴力操作或使用不当造成的损坏。  
 ■ 除经授权的零售商或SPERAS本身以外的任何人进行的不当维护或修理。

**深圳市思贝照明有限公司**  
 地址: 深圳市龙华新区大浪街道华宁路  
 港深创新园G栋420-424  
 电话: +86-755-2107-2597  
 网址: www.speraslight.com  
 邮箱: info@speraslight.com

### 保修卡

产品型号: \_\_\_\_\_  
 产品序列号: \_\_\_\_\_  
 购买日期: \_\_\_\_\_  
 经销商签名/盖章: \_\_\_\_\_

**感谢您选择 SPERAS.**  
 SPERAS 手电筒自购买之日起享有 5 年保修。  
 购买后请要求经销商填写购买日期并在保修卡上签字/盖章。  
 如果需要帮助, 请联系 SPERAS 手电筒的经销商。

注意: 保修条款仅涵盖制造商缺陷。

双面印刷 折后尺寸60x90mm