

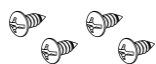

CPT100-1 Wire Extender for Wi-Fi Thermostats Installation/User Guide

In The Box

CPT100-1
Wire Extender
with Wire
Harness



Mounting Screws Double-sided Adhesive



Installation/
User Guide

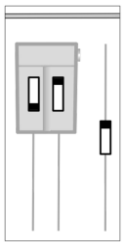

Diode
Pack

(855)632-0620 • support@invertercool.com • www.invertercool.com

Instructions may change without notice, always check www.invertercool.com for the latest installation details.

Product Introduction

The InverterCool CPT100-1 Wire Extender is a simple solution to allow installation of InverterCool CPT100 with 2, 3 or 4 wire connections.

! WARNING

BEFORE installing the CPT100-1 Wire Extender, turn off all power to the appliance. Be aware that more than one electrical disconnect may be required to do this.

Safety Instructions

Read these instructions carefully before installing and using the Wire Extender. Installation/repairs must be in strict accordance with regulating agencies for the local jurisdiction.

! Warning - Indicates a safety hazard that may cause severe personal injury, death or property damage.

Installation The following wiring diagrams show electrical connections between a CPT100 Wi-Fi Thermostat and the CPT100-1 Wire Extender as well as wiring between the Wire Extender and the appliance. To enable the internal diode pair in the Thermostat, move the jumper to the outer position (shown below)

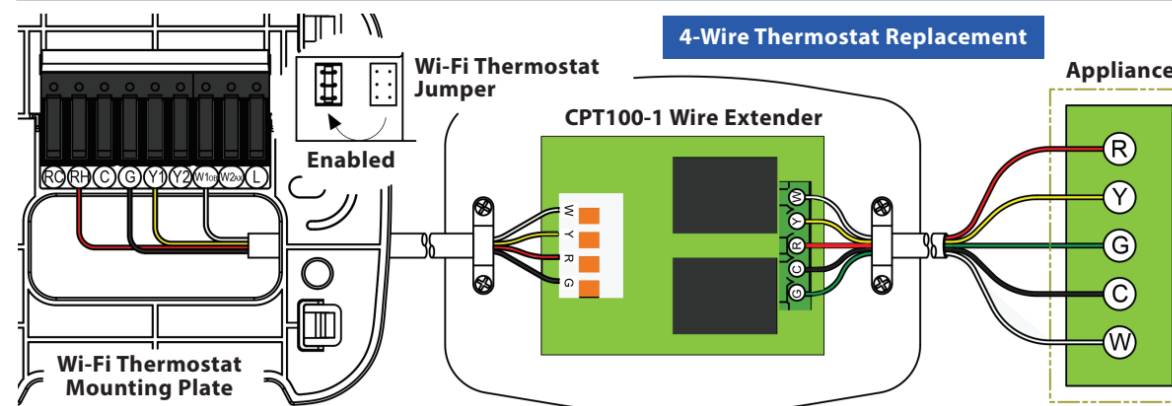
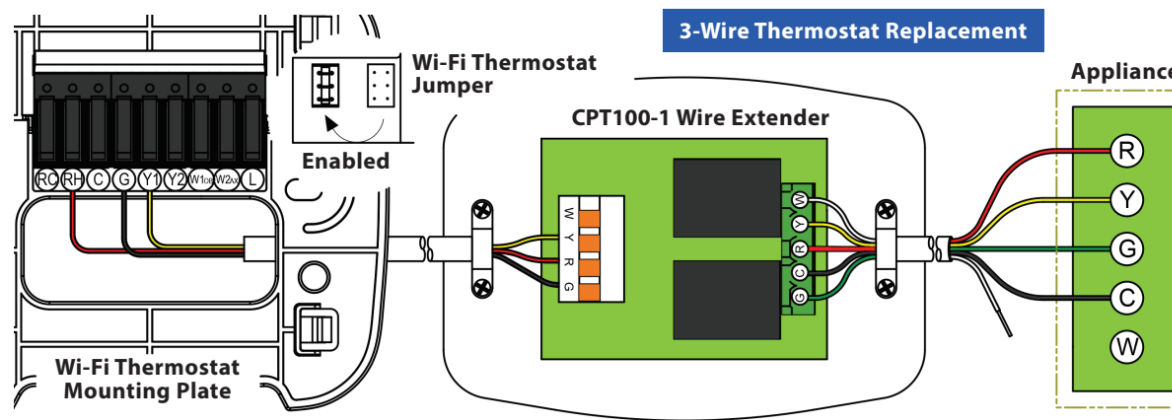
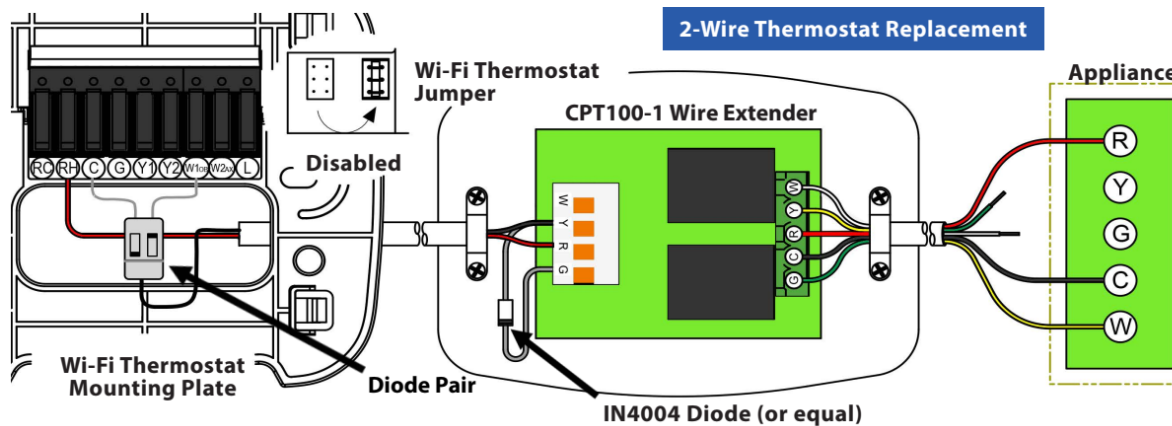

Mounting Location

This Wire Extender can be mounted inside the cabinet, on an exterior cabinet surface or on a wall adjacent to the unit.

- The included harness is 36" (500 mm) long to maximize installation flexibility.
- Mount the Wire Extender on a wall or fixed appliance panel. **DO NOT OBSTRUCT** access openings or panels.

Wiring Requirements

To be sure the installation location is within easy reach of the appliance, it may be easiest to connect the wiring before mounting the device.

- Be sure to feed the wire through a hole in the cabinet that is free of sharp edges and allows access covers to be re-installed before finalizing the installation.
- Use a maximum 100 feet (30 meters) of 18-gauge wire or 36 feet (11 meters) of 22-gauge wire between the Wire Extender and the Thermostat.
- Wiring must comply with all applicable local, state and national codes. In the absence of local requirements, use ANSI/NFPA 70, National Electrical Code.

CPT100 Wi-Fi Thermostat Jumper



Connecting the CPT100-1

Carefully examine the wiring that connects to your existing thermostat. If there is no "C" wire (common), you will need to use the CPT100-1 Wire Extender to connect your new CPT100 to your system.

Note: Other thermostats may have different termination requirements.

The number of wires, and where they connect on the existing thermostat will guide you in how to connect the CPT100-1.

The 3 diagrams on the previous page are the most common for heating, cooling, and heat/cool systems.

Newer systems will typically have a 3 or 4-wire connection between the equipment and the thermostat. Older systems often only have 2 wires and require the addition of the enclosed diodes.

The single diode is connected to the CPT100-1 "Y" & "G" terminals with the polarity as shown.

The leads of the diode pair are typically connected to the "C" and "W1" terminals on the thermostat terminal block. with the polarity as shown.

The power wire, typically red, connects to the "R" terminal while the second wire, typically black, is connected to the screw terminal on the top of the diode pair.

Be certain to position the diode pair housing so that it will be recessed in the wall opening.

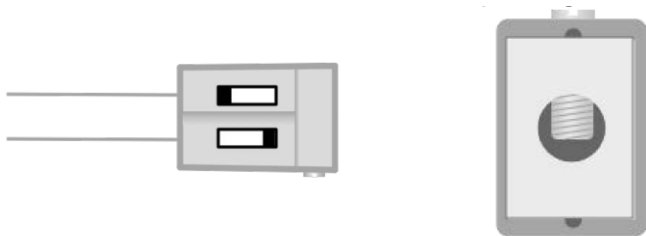

Specifications

Operating Conditions	32 - 104°F(0 - 40°C) Max.RH 90%(non-condensing)
Storage Conditions	-4 - 185°F(-20-85°C) Max.RH 90%(non-condensing)
Power Input	24VAC±10%
Dimensions	3.7" x 2.6" x 0.9" 9.4 cm x 6.6 cm x 2.3 cm

FCC Statements

WARNING: Changes or modifications to this unit not expressly approved by the party responsible for compliance could void the user's authority to operate the equipment.

This device complies with Part 15 of the FCC Rules. Operation is subject to the following two conditions:

- (1) this device may not cause harmful interference, and
- (2) this device must accept any interference received, including interference that may cause undesired operation.

NOTE: This equipment has been tested and found to comply with the limits for a Class B digital device, pursuant to Part 15 of the FCC Rules. These limits are designed to provide reasonable protection against harmful interference in a residential installation. This equipment generates, uses and can radiate radio frequency energy, and if not installed and used in accordance with the instructions, may cause harmful interference to radio communications. However, there is no guarantee that interference will not occur in a particular installation. If this equipment does cause harmful interference to radio or television reception, which can be determined by turning the equipment off and on, the user is encouraged to try to correct the interference by one or more of the following measures:

- Reorient or relocate the receiving antenna.
- Increase the separation between the equipment and receiver.
- Connect the equipment into an outlet on a circuit different from that to which the receiver is connected.
- Consult the dealer or an experienced radio/TV technician for help.

FCC and Industry Canada

RF Radiation Exposure statement: This equipment complies with FCC and Industry Canada RF radiation exposure limits set forth for an uncontrolled environment. This equipment should be installed and operated with a minimum distance of 20 centimeters between the antenna and all persons.

Industry Canada

This device complies with Industry Canada license-exempt RSS standard(s). Operation is subject to the following two conditions:

- (1) this device may not cause interference, and
- (2) this device must accept any interference, including interference that may cause undesired operation of the device.

Le présent appareil est conforme aux CNR d'Industrie Canada applicables aux appareils radio exempts de licence. L'exploitation est autorisée aux deux conditions suivantes:

- (1) l'appareil ne doit pas produire de brouillage, et
- (2) l'utilisateur de l'appareil doit accepter tout brouillage radioélectrique subi, même si le brouillage est susceptible d'en compromettre le fonctionnement.

InverterCool Warranty

InverterCool, Inc. ("InverterCool") warrants that for a period of five (5) years ("Warranty Period") from the date of purchase by the consumer ("Customer"), this device, excluding batteries ("Product"), shall be free of defects in materials and workmanship under normal use and service in accordance with all supplied instructions.

During the warranty period, InverterCool shall, at its option, repair or replace any defective Products, at no charge for the device. Any replacement and/or repaired devices are warranted for the remainder of the original Warranty Period or ninety (90) days, whichever is longer. This warranty does not cover removal or reinstallation costs. This warranty does not apply to any Product

- (i) which has been modified, repaired, or altered, except by InverterCool or an authorized InverterCool representative,
- (ii) which has not been maintained in accordance with any handling or operating instructions supplied by InverterCool, or
- (iii) which has been subjected to unusual physical or electrical stress, misuses, abuse, negligence, or accidents.

This warranty is the only express warranty InverterCool makes for the Product. Any implied warranties, including warranties of merchantability or fitness for a particular purpose, are limited to the Warranty Period or the shortest period allowed by law.

InverterCool SHALL NOT BE LIABLE FOR ANY LOSS OR DAMAGE OF ANY KIND, INCLUDING ANY SPECIAL, INCIDENTAL OR CONSEQUENTIAL DAMAGES RESULTING, DIRECTLY OR INDIRECTLY, FROM ANY BREACH OF ANY WARRANTY, EXPRESS OR IMPLIED, OR ANY OTHER FAILURE OF THIS PRODUCT.

Some states and provinces do not allow the exclusion or limitation of incidental or consequential damages, or limitation on the duration of implied warranties of merchantability or fitness, so these exclusions or limitations may not apply to you. No oral or written information or advice given by InverterCool or a InverterCool-authorized representative shall modify or extend this warranty. If any term is held to be illegal or unenforceable, the legality or enforceability of the remaining terms shall not be affected or impaired. Customer's sole and exclusive remedy under this limited warranty is product repair or replacement as provided herein. If a Product under warranty is defective, the Customer may: Contact the party ("Seller") from which the Customer purchased the Product to obtain an equivalent replacement product after the Seller has determined that the Product is defective and the Customer is eligible for a replacement, or Contact InverterCool Service at support@invertercool.com, to determine whether the device qualifies for a replacement. If a replacement is warranted and is shipped prior to the return of the device under warranty, a credit card is required and a hold may be placed on the Customer's credit card for the value of the replacement until the returned device is verified as eligible for replacement, in which case, the Customer's credit card will not be charged. This warranty gives you specific legal rights, and you may also have other rights that vary from jurisdiction to jurisdiction. If you have any questions regarding this warranty, please write InverterCool at:

InverterCool, Inc.

6611 NW 84th Ave, Miami, FL 33166