

Installation Manual

High Efficiency Air Handlers
2-3-4-5Ton Capacity
R-410A TXV Inside



Contents

1. Safety-----	2
2. Dimensions-----	4
3. Applications-----	6
4. Electrical Wiring-----	9
5. Airflow Performance-----	14
6. Ductwork-----	15
7. Pipe Connections-----	16
8. Air Filter-----	17
9. TXV Adjustment-----	18



NOTE: Appearance of unit may vary.



Installation must be performed in accordance with the requirements of NEC and CEC by authorized personnel only.

All phases of this installation must comply with National, State and Local Codes.

IMPORTANT

This document is customer's property and is to remain with this unit. Please return it to customer with service information upon completion of work.

These instructions are intended as an assist to qualified and licensed personnel for proper installation, adjustment and operation of ECM air handler units. Read it thoroughly before attempting installation or service work. **Failure to follow these instructions may result in fire, electrical shock, property damage, personal injury or death.**

The instructions do not cover all variations in systems or provide for every possible contingency to be met in connection with the installation.

1. Safety

Read the following safety instructions before installing the unit or doing service work.

 **WARNING** may cause personal death or serious injury.

 **CAUTION** may lead to injury or structural damage under some conditions.



WARNING

Disconnect all power to unit before installing or servicing. More than one disconnecting switch may be required to de-energize the equipment. Hazardous voltage can cause severe personal injury or death.

Installation and maintenance must be performed by authorized personnel only. Consumer service is recommended only for filter cleaning/replacement. Never operate the unit with the access panels removed.

Failure to inspect pipes or use proper service tools may result in equipment damage or personal injury. If using existing refrigerant pipes, make sure that all joints are brazed, not soldered.

The unit must be permanently grounded. Failure to do so can result in electrical shock causing personal injury or death.

PROPOSITION 65: This appliance contains fiberglass insulation. Respirable particles of fiberglass are known to State of California to cause cancer. All manufacturer products have to meet current federal OSHA Guidelines for safety.

California Proposition 65 warnings are required for certain products that are not covered by the OSHA standards. It requires warnings for products sold in California that contain or produce any of over 600 listed chemicals known to the State of California to cause cancer or birth defects such as fiberglass insulation, lead in brass, and combustion products from natural gas.

All “new equipment” shipped for sale in California will have labels stating that the product contains and /or produces Proposition 65 chemicals. Although we have not changed our processes, having the same label on all our produced facilitates manufacturing and shipping. We cannot always know “when or if” products will be sold in the California market. You may receive inquiries from customers about chemicals found in, or produced by, some of our heating and air-conditioning equipment, or found in natural gas used with some of our products. Listed below are those chemicals and substances commonly associated with similar equipment in our industry and other manufacturers.

- Glass Wool (Fiberglass) Insulation
- Carbon Monoxide (CO).
- Formaldehyde
- Benzene

More details are available at the websites for OSHA (Occupational Safety and Health Administration), at www.osha.gov and the State of California’s OEHHA (Office of Environmental Health Hazard Assessment) at www.oehha.org. Consumer education is important since the chemicals and substances on the list are found in our daily lives. Most consumers are aware that products present safety and health risks, when improperly used, handled and maintained.



WARNING

If removal of the blower assembly is required, all switches supplying power to the equipment must be disconnected and locked so the field power wires can be safely removed from the blower assembly. Failure to do so can cause electrical shock resulting in personal injury or death.

Make sure the blower motor support is tight (3-motor mount bolts), then check if the wheel is secure to motor shaft before operating unit.

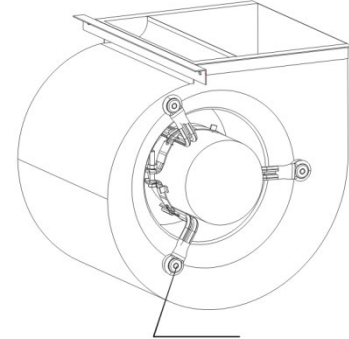

BLOWER MOTOR MOUNTING BOLT

The first 6 inches of supply air plenum and ductwork must be constructed of sheet metal as required by NFPA 90B. The supply air plenum or duct must have a solid sheet metal bottom directly after the air handler unit with no openings, registers or flexible air ducts located in it. If flexible supply air ducts are used, they may be located only in the vertical walls of rectangular plenum, a minimum of 6 inches from the solid bottom. Metal plenum or duct may be connected to the combustible floor base, if not, it must be connected to the unit supply duct exposed to the supply air opening from the down-flow unit.

Exposing combustible (non-metal) material to the supply opening of a down-flow unit may cause a fire resulting in property damage, personal injury or death.

2. Dimensions

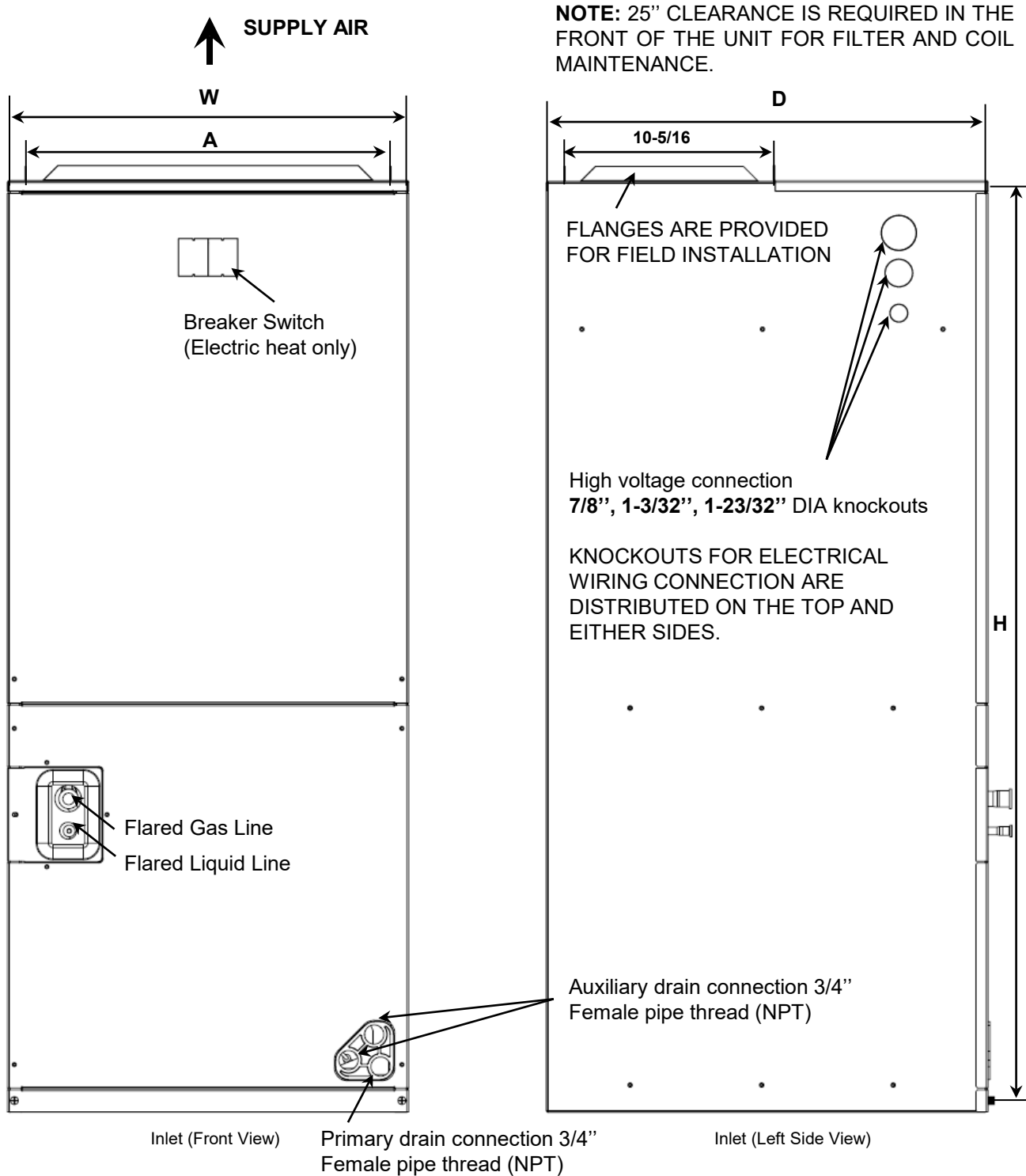
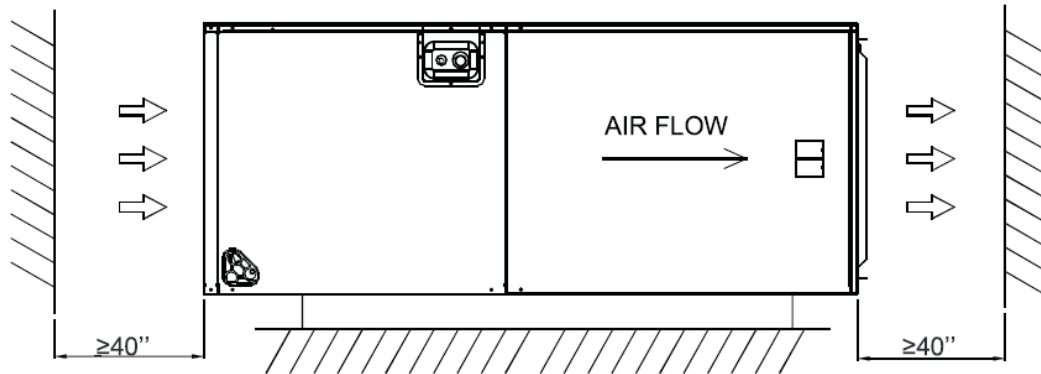

Figure 2-1 Unit Dimensions

Model Number	Dimensions (in.)					
	H	W	D	A	Liquid Line Connection	Gas Line Connection
24 / 36	46-1/2	21	21	19-1/4	3/8	3/4
48 / 60	56	24-1/2	21	22-3/4	3/8	7/8

Select a solid and level site, keep enough space for proper installation and maintenance.

Adjust motor speed tap on indoor PCB to select correct air flow according to blower performance table.



a) Horizontal Position

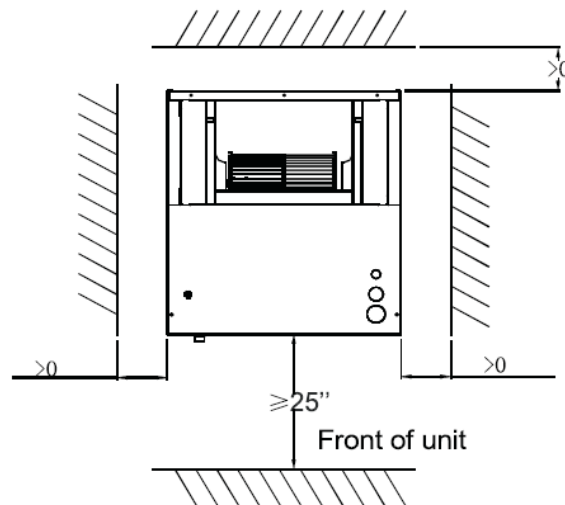

b) Vertical Position

Figure 2-2 Clearance requirement

3. Applications

3.1 Vertical up-flow and Horizontal right-flow

Vertical up-flow and horizontal right-flow configurations are the factory settings on all models. If return air is to be ducted, install duct flush with floor. Use fireproof resilient gasket 1/8 to 1/4 in. thick between the ducts, unit and floor. Set unit on floor over opening.

IMPORTANT

Lightly tighten the drain connections so it won't leak.

Using excessive force may cause damage to the drain connections. Torque applied to drain connections should not exceed 10.ft.lbs.

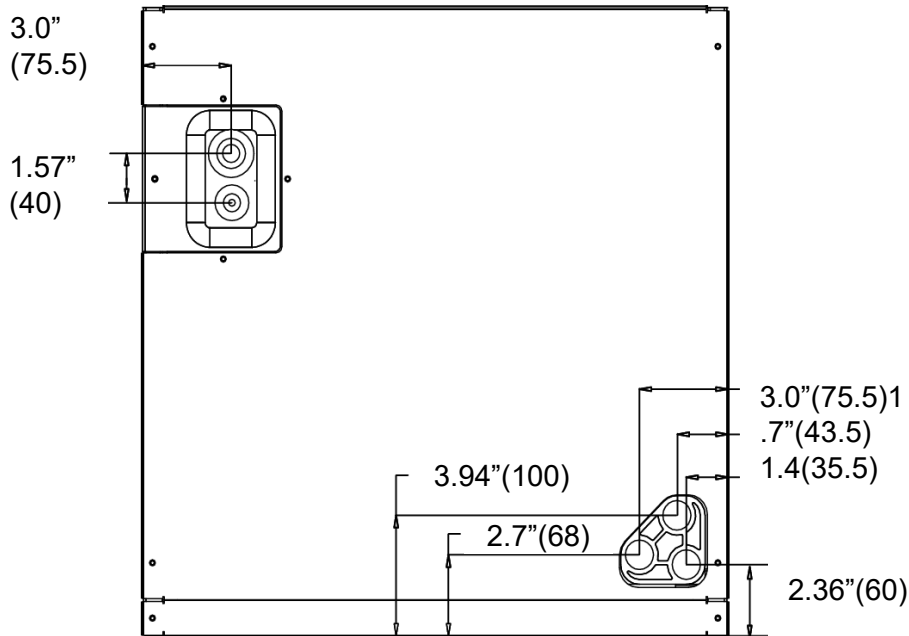

Figure 3-1 Dimensions for front connection coil

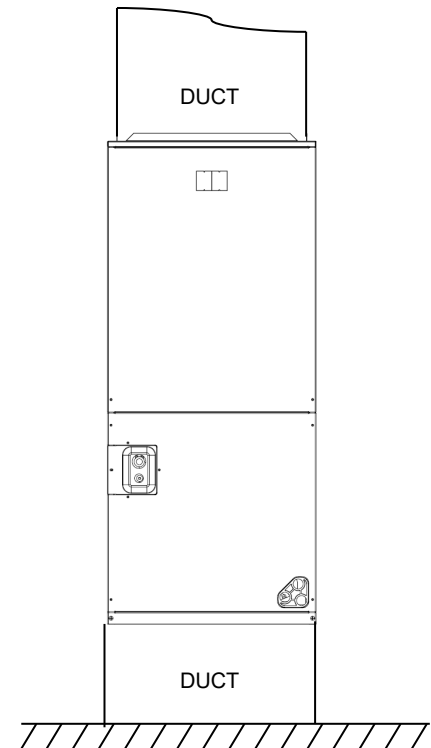

Figure 3-2 Vertical up-flow

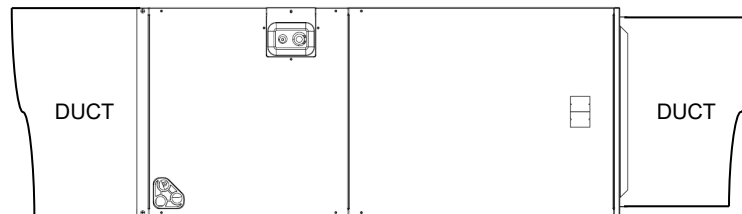

Figure 3-3 Horizontal right-flow

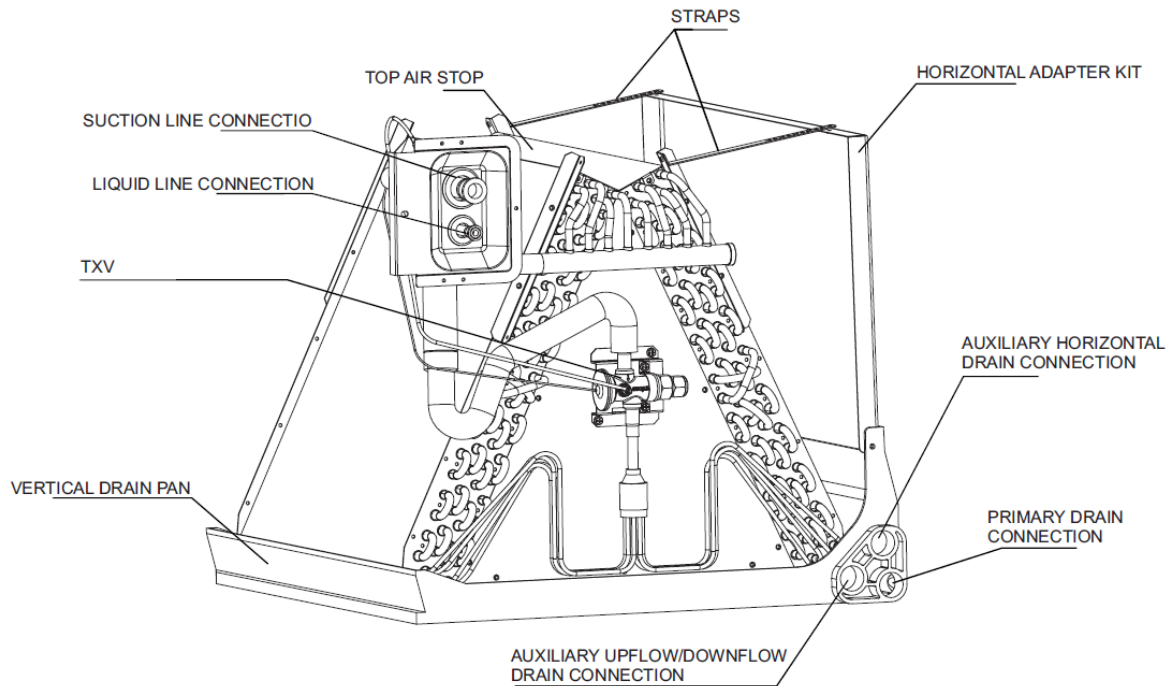

Figure 3-4 Dimensions for front connect coil

CAUTION

Horizontal units must be configured for right hand air supply or left hand air supply. Horizontal drain pan must be located under indoor coil. Failure to use the drain pan can result in property damage.

3.2 Installation in an unconditioned space

There are two pairs of coil rails in the air handler for default and counter flow application. If the air handler is installed in an unconditioned space, the two unused coil rails should be removed to minimize air handler surface sweating. The coil rails can be easily removed by taking off the 6 mounting screws from both sides of the cabinet.

4. Electrical Wiring

Field wiring must comply with the National Electric Code (C.E.C. in Canada) and any applicable local ordinance.

WARNING

Disconnect all power to unit before installing or servicing. More than one disconnect switch may be required to de-energize the equipment. Hazardous voltage can cause severe personal injury or death.

4.1 Power Wiring

It is important that proper electrical power is available for connection to the unit model being installed. Refer to the unit nameplate, wiring diagram and electrical data in the installation instructions.

- If required, install a branch circuit disconnect of adequate size, located within sight of, and readily accessible to the unit.
- When the electric heat is installed, units may be equipped with one or two 30~60 amp. circuit breakers. These breakers protect the internal wiring in the event of a short circuit and serve as a disconnect. Circuit breakers installed within the unit do not provide over-current protection of the supply wiring and therefore may be sized larger than the branch circuit protection.
- Supply circuit power wiring must be 167° F minimum copper conductors only. Refer to electrical data in this section for ampacity, wire size and circuit protector requirements. Supply circuit protective devices may be either fuses or “HACR” type circuit breakers.

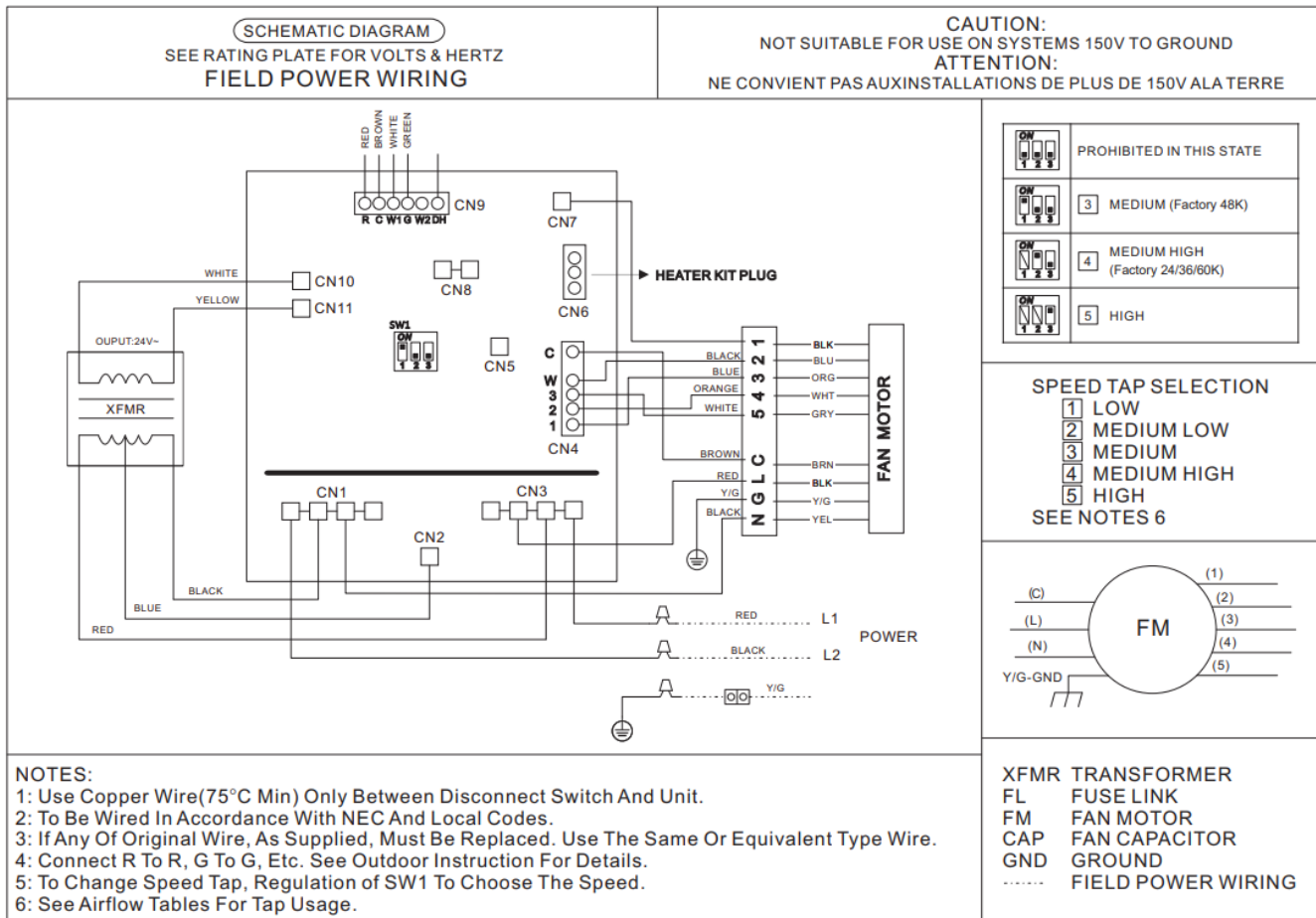
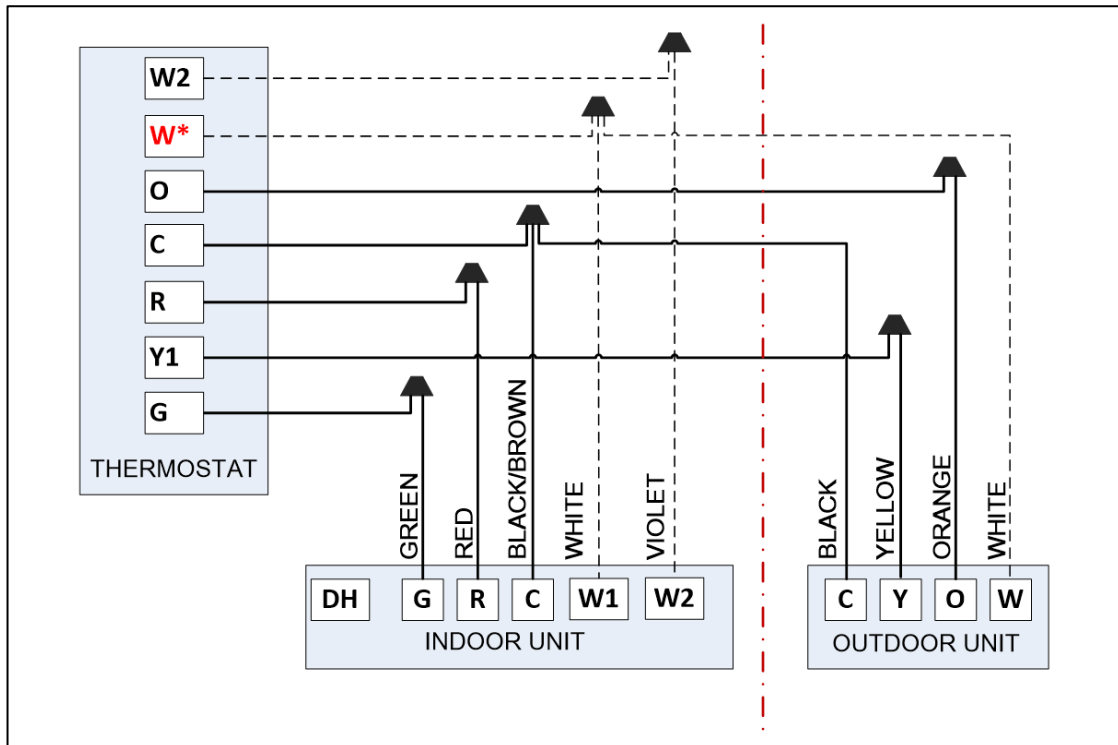

Figure 4-1 Wiring Diagram

4.2 Control Wiring

Class 2 low voltage control wiring should not be run in conduit with main power wiring and must be separated from power wiring, unless class 1 wire of proper voltage rating is used.

- Low voltage control wiring should be color-coded **18 AWG**. For lengths longer than 100 ft., 16 AWG wire shall be used.
- Refer to wiring diagrams attached to indoor and outdoor sections to be connected.
- Make sure separation of control wiring and power wiring has been maintained.



NOTES:

1. Be sure power supply agrees with equipment nameplate.
2. Power wiring and grounding of equipment must comply with local codes.
3. Low voltage wiring to be No. 18 AWG minimum conductor.
4. "----" means the electric auxiliary heat connection. * Some thermostats may use W2/AUX for heat pump.

Figure 4-2 Schematic diagram for control wiring connection

4.3 Grounding

WARNING

The unit must be permanently grounded.

Failure to do so can result in electrical shock causing personal injury or death.

- Grounding may be accomplished by grounding metal conduit when installed in accordance with electrical codes to the unit cabinet. Grounding may also be accomplished by attaching ground wire(s) to ground lug(s) provided in the unit wiring compartment.
- Use of multiple supply circuits require grounding of each circuit to lug(s) provided in the unit.

4.4 Electrical Data

Model Number	Voltage-Phase-Hz	Power Supply Wiring Gauge	Motor HP	Motor Steps	Minimum Circuit AMPS.	Fuse (A)
24	208/230-1Ph-60Hz	14	1/3	5	3.0	15
36			1/2		5.2	
48			3/4		7.5	
60			3/4		7.5	

4.5 Electric Heater Kit

Kit Model	Model Number	Heating Capacity (kW)	MIN. Circuit Ampacity		MAX. Fuse or Breaker (HACR) Ampacity		Fan speed				
			240	208	240	208	1	2	3	4	5
EHK05	24	5	25	22	30	25	x	●	●	●	●
EHK10		10	49	43	60	50	x	x	●	●	●
EHK05	36	5	25	22	30	25	x	●	●	●	●
EHK10		10	49	43	60	50	x	x	●	●	●
EHK15		5+10	25+49	22+43	30+60	25+50	x	x	●	●	●
EHK05	48	5	25	22	30	25	x	●	●	●	●
EHK10		10	49	43	60	50	x	●	●	●	●
EHK15		5+10	25+49	22+43	30+60	25+50	x	x	●	●	●
EHK20		10+10	49+49	43+43	60+60	50+50	x	x	x	●	●
EHK05	60	5	25	22	30	25	x	x	●	●	●
EHK10		10	49	43	60	50	x	x	●	●	●
EHK15		5+10	25+49	22+43	30+60	25+50	x	x	●	●	●
EHK20		10+10	49+49	43+43	60+60	50+50	x	x	x	●	●

Electric heater kits are suitable for air handler multiple position installation.

● means available x means unavailable

Safety Cautions All electric work must be performed by qualified personnel.

EHK series is designed and approved to be installed in the SVS indoor unit(air handlers).

- Check the EHK label to confirm EHK size based on room load under lowest temperature ambient.
- Inspect all porcelain in insulators for breakage and the intact of heater element wire. Contact local distributor immediately if there is any occurred damage.



Warning

- Disconnect all external power supplies before performing installation and servicing. Turn off accessory heater power switch if applicable. Failure to do so may cause serious injury.
- EHK must be properly grounded and use copper supply wires.
- Make sure to follow national electric code and local regulations.
- When installing it in an enclosed area such as a garage, heater elements should have a minimum clearance of 18" from the floor to insure the proper ventilation.

4.6 Electric Heater Installation Guide

STEP 1. Unfasten 4 screws to take away the blower access panel of the air handler.

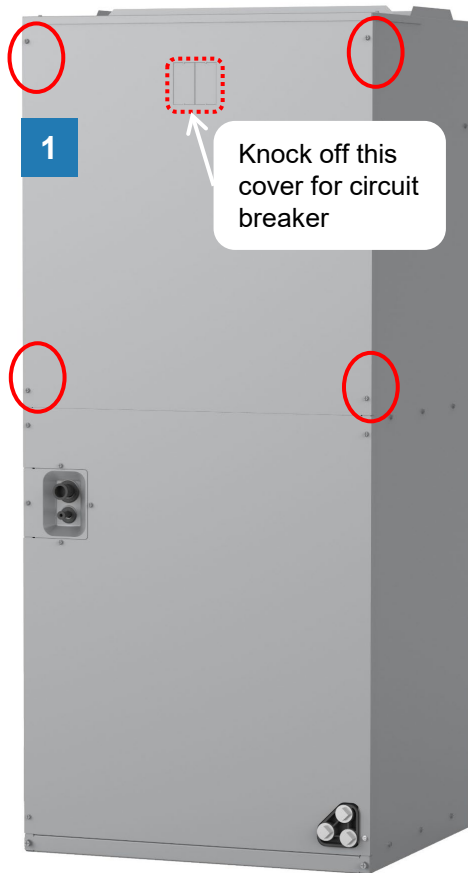

STEP 2. Remove cover plate based on actual requirement.

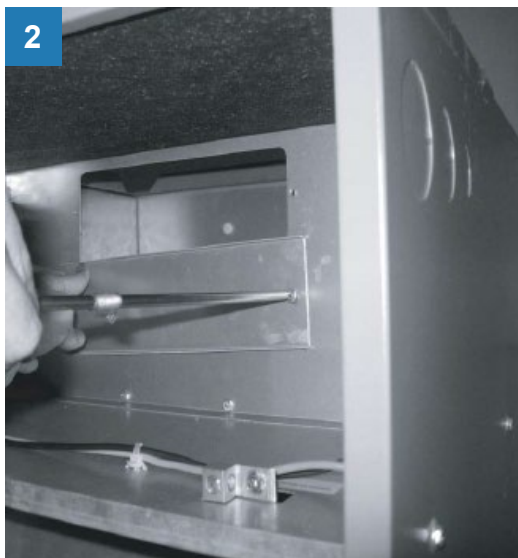

STEP 3. Slide the kit into the duct and fasten the element (e.g. attachment and wires).

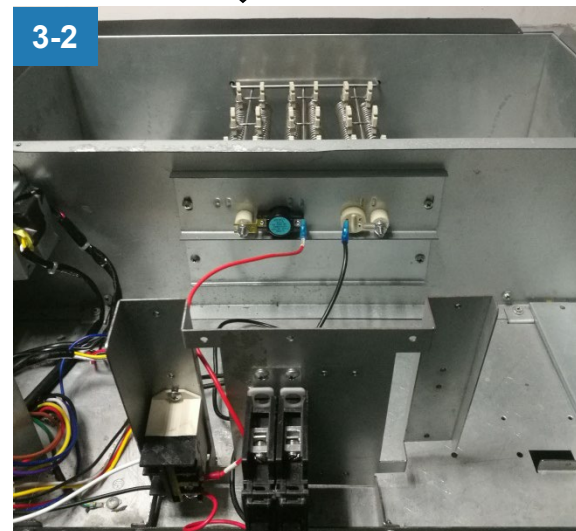

STEP 4. Install the circuit breaker into the mounting rail. Knock off the reserved cover for breaker in blower access panel prior to put it back to the unit.

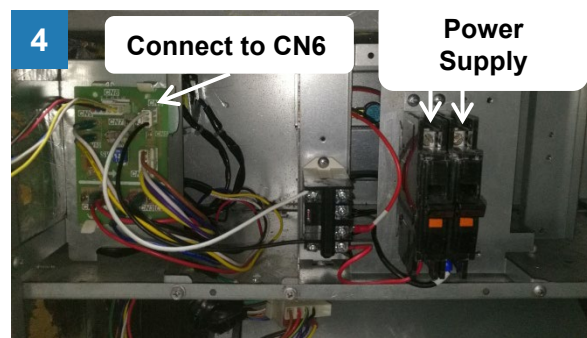

WARNING

Disconnect all power to unit before installing or servicing. More than one disconnect switch may be required to de-energize the equipment. Hazardous voltage can cause severe personal injury or death.

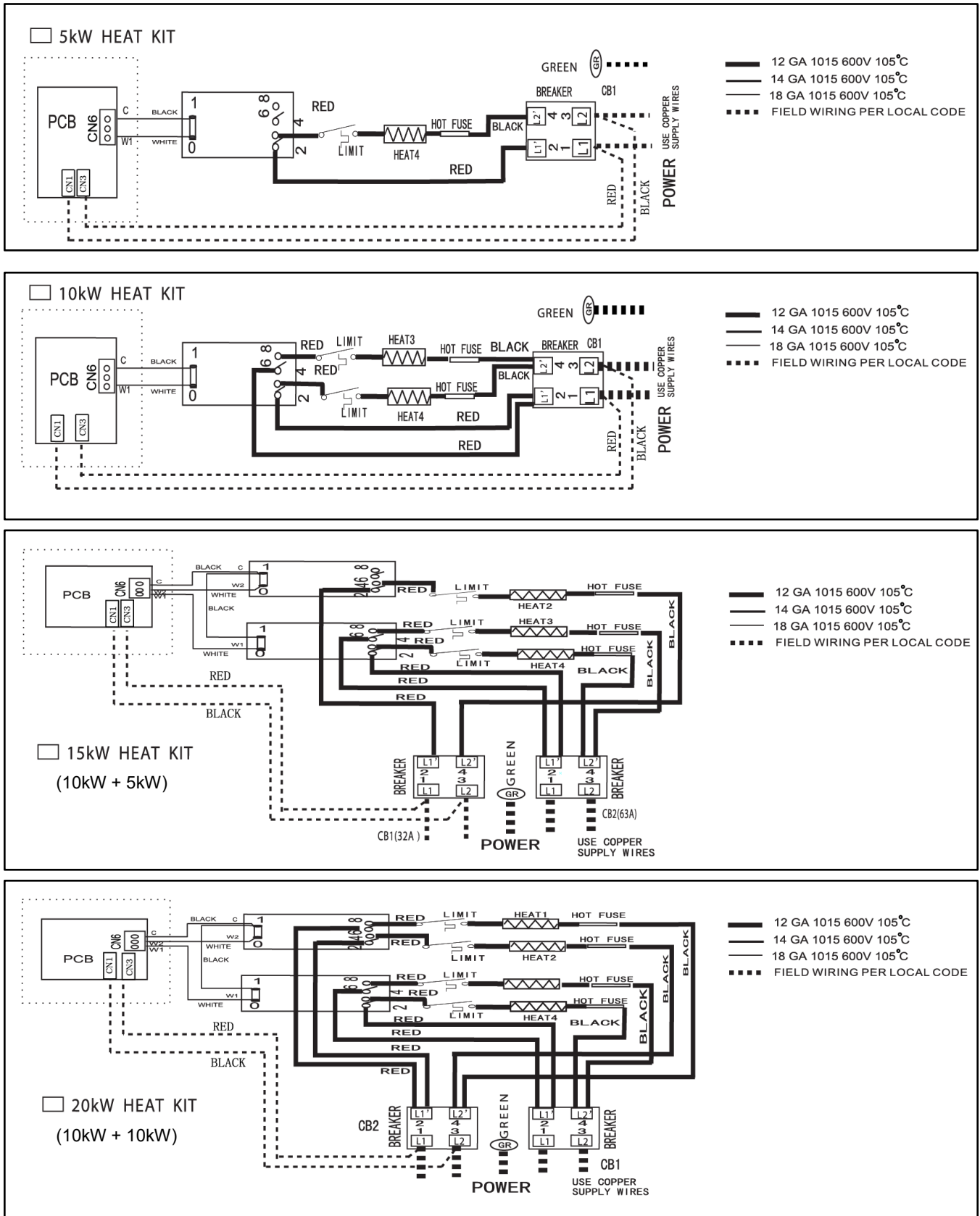

Figure 4-3 Wiring diagram for electric heat

5. Airflow Performance

Airflow performance data is based on cooling performance with a coil and no filter in place. Check the Performance table for appropriate unit size selection. External static pressure should stay within the minimum and maximum limits shown in the table below in order to ensure proper airflow.

Model	Motor Speed		SCFM / Watts										
			External Static Pressure-Inches W.C.[KPa]										
			0 [0]	0.1 [.02]	0.16 [.04]	0.2 [.05]	0.3 [.07]	0.4 [.10]	0.5 [.12]	0.6 [.15]	0.7 [.17]	0.8 [.20]	
24	Tap (5)	SCFM	1091	1041	1016	1001	950	905	857	803	740	691	
		Watts	170	179	186	189	199	208	217	227	239	244	
	Tap (4)- factory	SCFM	928	888	854	833	792	721	658	622	562	517	
		Watts	106	117	121	124	135	143	154	162	170	178	
	Tap (3)	SCFM	832	773	757	729	692	626	572	522	473	406	
		Watts	78	84	90	92	101	111	121	128	134	144	
	Tap (2)	SCFM	708	655	620	599	539	478	423	389	331	279	
		Watts	55	62	66	70	80	86	92	101	108	115	
	Tap (1)	SCFM	658	573	548	521	446	403	342	289	230	189	
		Watts	46	49	55	59	66	75	80	89	93	99	
	36	Tap (5)	SCFM	1458	1412	1390	1366	1320	1274	1194	1167	1072	1027
			Watts	280	295	298	300	308	317	327	337	350	357
Tap (4)- factory		SCFM	1287	1240	1210	1192	1149	1077	1006	939	888	832	
		Watts	203	212	216	221	228	232	246	258	266	272	
Tap (3)		SCFM	1133	1084	1057	1035	979	896	835	777	724	670	
		Watts	147	154	157	162	169	180	190	197	204	211	
Tap (2)		SCFM	929	872	839	796	716	653	598	527	460	380	
		Watts	81	92	95	100	114	120	127	136	143	153	
Tap (1)		SCFM	802	756	692	651	594	525	453	355	270	210	
		Watts	60	69	72	78	87	91	98	108	114	119	
48		Tap (5)	SCFM	1952	1909	1884	1866	1827	1784	1740	1697	1658	1616
			Watts	574	581	585	589	596	608	611	623	635	643
	Tap (4)	SCFM	1766	1725	1701	1678	1643	1598	1551	1507	1457	1403	
		Watts	418	429	436	443	453	462	468	479	485	496	
	Tap (3)- factory	SCFM	1558	1514	1489	1471	1433	1389	1345	1302	1248	1191	
		Watts	297	308	318	324	334	346	359	369	374	391	
	Tap (2)	SCFM	1281	1261	1244	1199	1154	1111	1076	1015	966	912	
		Watts	165	178	189	192	206	220	232	250	263	272	
	Tap (1)	SCFM	998	966	956	917	883	835	794	745	701	646	
		Watts	89	103	111	115	130	146	159	174	181	196	
	60	Tap (5)	SCFM	1952	1909	1884	1866	1827	1784	1740	1697	1658	1616
			Watts	574	581	585	589	596	608	611	623	635	643
Tap (4)- factory		SCFM	1766	1725	1701	1678	1643	1598	1551	1507	1457	1403	
		Watts	418	429	436	443	453	462	468	479	485	496	
Tap (3)		SCFM	1558	1514	1489	1471	1433	1389	1345	1302	1248	1191	
		Watts	297	308	318	324	334	346	359	369	374	391	
Tap (2)		SCFM	1281	1261	1244	1199	1154	1111	1076	1015	966	912	
		Watts	165	178	189	192	206	220	232	250	263	272	
Tap (1)		SCFM	998	966	956	917	883	835	794	745	701	646	
		Watts	89	103	111	115	130	146	159	174	181	196	

Shaded boxes represent airflow outside the required 300-450CFM/Ton.

NOTES:

Airflow based upon cooling performance at 230V with no electric heat and no filter. Airflow at 208V is approximately the same as 230V because the multi-tap ECM motor is a constant torque motor. The torque doesn't drop off at the speeds in which the motor operates.

6. Ductwork

Field ductwork must comply with the National Fire Protection Association NFPA 90A, NFPA 90B and any applicable local ordinance.

WARNING

Do not, under any circumstances, connect return ductwork to any other heat producing device such as fireplace insert, stove, etc. Unauthorized use of such devices may result in fire, carbon monoxide poisoning, explosion, personal injury or property damage.

Sheet metal ductwork run in unconditioned spaces must be insulated and covered with a vapor barrier. Fibrous ductwork may be used if constructed and installed in accordance with SMACNA Construction Standard on Fibrous Glass Ducts. Ductwork must comply with National Fire Protection Association as tested by U/L Standard 181 for Class I Air Ducts. Check local codes for requirements on ductwork and insulation.

- Duct system must be designed within the range of external static pressure the unit is designed to operate against. It is important that the system airflow be adequate. Make sure supply and return ductwork, grilles, special filters, accessories, etc. are accounted for in total flow resistance. Refer to the airflow performance table in this manual.
- Design the duct system in accordance with “ACCA” Manual “D” Design for Residential Winter and Summer Air Conditioning and Equipment Selection. Latest editions are available from: “ACCA” Air Conditioning Contractors of America, 1513 16th Street, N.W., Washington, D.C. 20036. If duct system incorporates flexible air duct, be sure that the pressure drop Information (straight length plus all turns) shown in “ACCA” Manual “D” is accounted for in system.
- Supply plenum is attached to the 3/4” duct flanges supplied with the unit. Attach flanges around the blower outlet.
- Secure the supply and return ductwork to the unit flanges, using proper fasteners for the type of duct used and tape the duct-to-unit joint as required to prevent air leaks.

IMPORTANT

If an elbow is included in the plenum close to the unit, it must not be smaller than the dimensions of the supply duct flange on the unit.

The front flange on the return duct connected to the blower casing must not be screwed into the area where the power wiring is located. Drills or sharp screw points can damage insulation on wires located inside unit.

7. Pipe Connections

Keep the coil connections sealed until refrigerant connections are made. Refer to condensing unit installation instructions for details on pipe size and insulation.

- Coil is shipped with Nitrogen. Evacuate the system before charging with refrigerant.
- Make sure the refrigerant pipes layout do not block service access.
- Purge the refrigerant pipes and indoor coil with dry nitrogen while brazing.
- Use a wet rag or an approved heat paste to protect the TXV sensing bulb during the brazing process.

Condensate Drain Connection

1. Use a thin layer of Teflon paste, silicone or Teflon tape when making drain fitting connections.
2. Do not over tighten fittings resulting in splitting pipe connections on the drain pan.

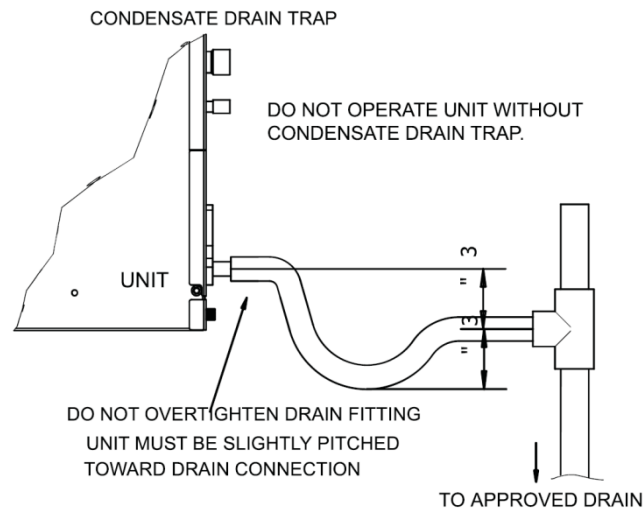

Figure 7-1 Condensate drain trap

- Make sure the drain pipes layout do not block service access. Minimum clearance of 24 inches is required for filter, coil or blower removal and service access.
- Ensure the unit is level or pitched slightly toward primary drain connection so that water will drain smoothly from the pan. All horizontal drain pipes must be pitched downward away from the unit a minimum of 1/8" per foot of line to ensure proper drainage.
- Do not reduce drain pipe size less than connection size provided on condensate drain pan.
- Do not connect condensate drain pipe to a closed or open sewer pipe.
- The drain pipe should be insulated where necessary to prevent sweating and damage due to condensate forming on the outside surface of the line.
- Make provisions for disconnecting and cleaning of the primary drain pipe if it become necessary. Install a 3-inch trap in the primary drain pipe as close as possible to the unit. Make sure that the top of the trap is below connection to the drain pan to allow complete drainage of pan.
- Auxiliary drain pipe should be connected to a place where it will be noticeable. Homeowner should be warned that a problem exists if water begins running from the auxiliary drain pipe.
- Test condensate drain pan and drain pipe after installation is complete. Pour enough water into drain pan, make sure that the drain pan is draining completely, no leaks are found in drain pipe fittings, and no water is draining from the termination of the primary drain pipe.

8. Air Filter

Filter application and replacement are critical to airflow, which may affect the heating and cooling system performance. Reduced airflow can shorten the life of the system's major components, such as motor, heat relays, evaporator coil or compressor. Units should be sized for a maximum of 300 feet/min. air velocity or what is recommended for the filter type installed.

Ensure the air flow is in the range of 300~450CFM if adding high efficiency filters or electronic air filtration systems. Note that the overall performance and efficiency of the unit will be reduced because of pressure drop by filters.

IMPORTANT

Do not double filter the return air duct.

Do not filter the supply air duct which will change the performance of the unit and reduce airflow .

WARNING

Do not operate the system without filters. A portion of the dust suspended in the air may temporarily lodge in the duct. Any circulated dust particles could be heated and charred by contact with the air handler elements. This residue could soil ceilings, walls, drapes, carpets and other articles in the house. Soot damage may occur without filters in place when certain types of candles, oil lamps or standing pilots are burned.

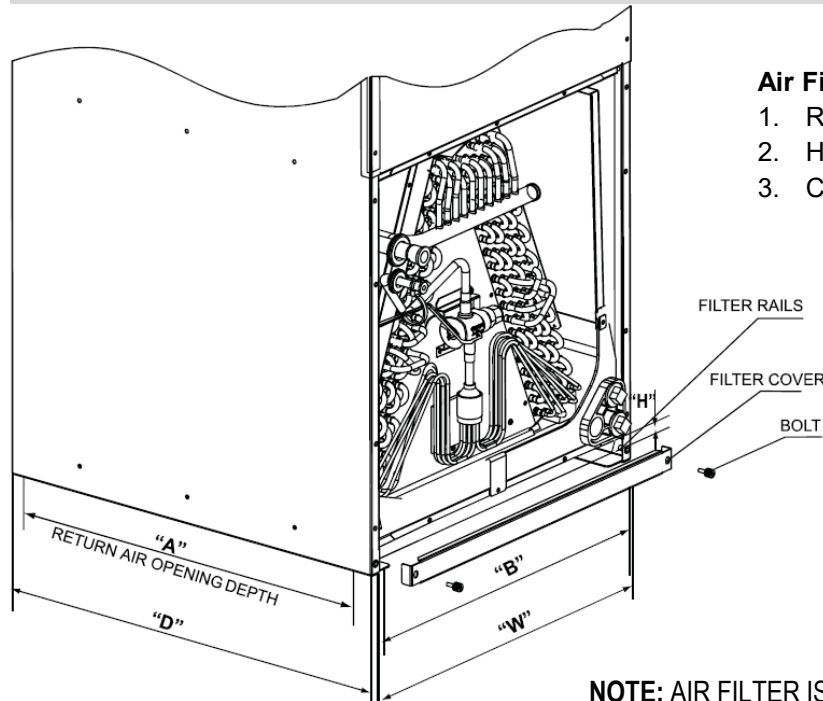

Air Filter Clean/Replacement

1. Remove bolts to take the filter cover away.
2. Hold the edge of the air filter and extract it out .
3. Clean the air filter or use a new one to replace.

NOTE: AIR FILTER IS NOT FACTORY INSTALLED.

Figure 8-1 Filter installation and clean

Model Number	Dimensions (inch)					
	Filter Size *1	W	D	H	A	B
24 / 36	18 x 20	19-3/4	21	1	16	13-7/8
48 / 60	22 x 20	23-1/4	21	1	16	15-1/4

NOTE:

1. Refer to the label on the air handler right next to the filter cover to install the correct filter size.

9. TXV Adjustment

To keep the best performance and reliability of Smart Variable Speed (SVS) system, be sure liquid line sub-cooling (SC) and compressor suction superheat (SSH) meet our requirements.

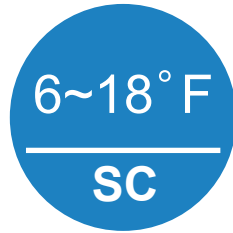

**Target SC and SSH
in cooling**



- If the LED displays "--" in AUTO charge mode for more than 20 minutes, stop charging and use a wrench to **clockwise** the TXV to ensure SH is no less than 7°F.
- In case that the cooling performance is abnormal due to improper superheat (i.e. SSH >20°F). Proceed as followings to complete the field adjustment.
 1. Activate AUTO charge mode from outdoor condensing unit to fix compressor speed (RPS) by press BS4 for 5 seconds on PCB. Run the system for 15~20 minutes to check refrigerant coefficient number from LED display or InverterCool FDD App, **add refrigerant until you get 0.6.**
 2. Open the front panel of the indoor unit, then use a wrench to **counterclockwise** the TXV until SSH ≤ 20°F. This will make more refrigerant flow into indoor coil for better cooling performance.

NOTE: Maintain a minimum of 5 minutes operation after every refrigerant amount or TXV opening adjustment, then check live SC and SSH on InverterCool FDD App.

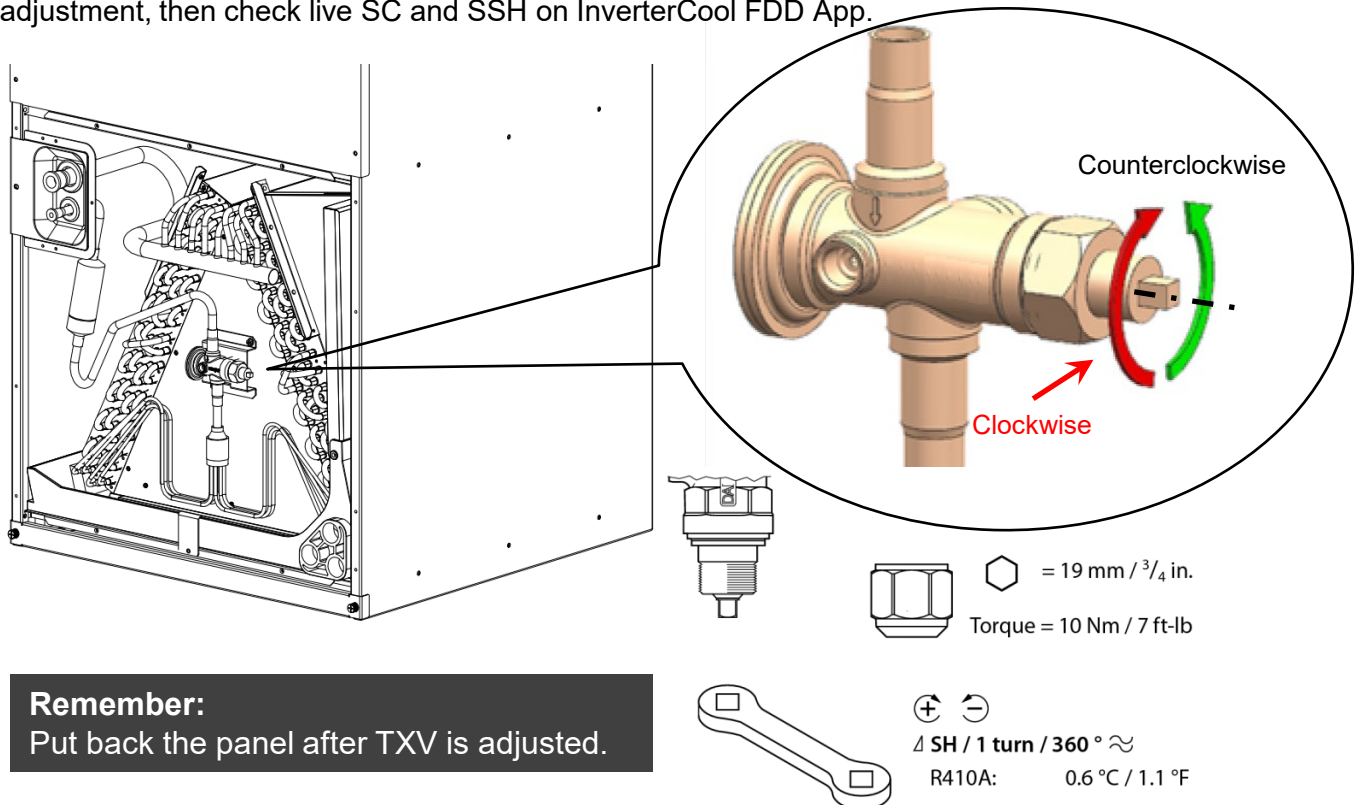

©2022 InverterCool, Inc.

6611 NW 84th Ave, Miami, FL 33166

Tel: 1 (855) 632 0620

www.invertercool.com