

**LCD-M6C Hand Control Panel Operation Instruction**

**2020 Latest Edition-V1.0**



一、 **Out shell Size and Material**

Out shell material is ABS, Liquid crystal transparent window material is high hardness acrylic.

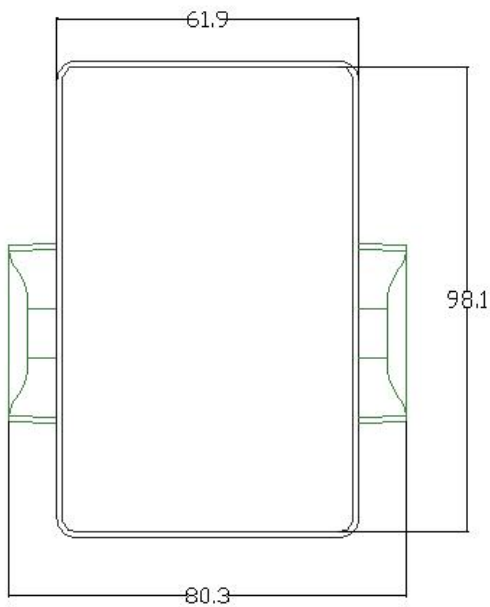

**Front view**

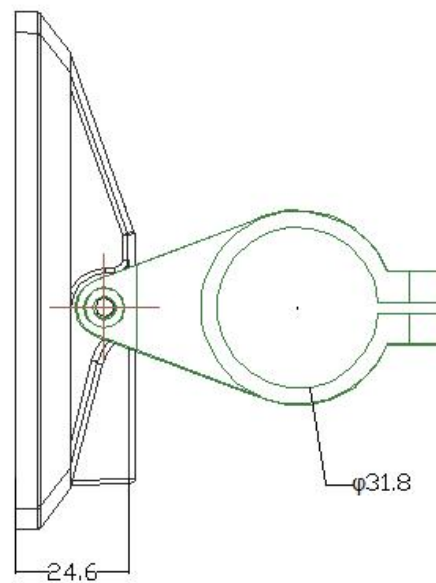

**Side view**

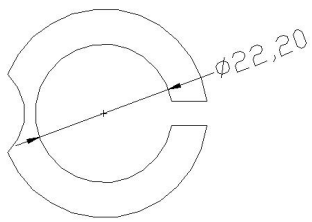

31.8mm stent is available 22.2mm、25.4mm、28.6mm

### Transfer Ring Selection

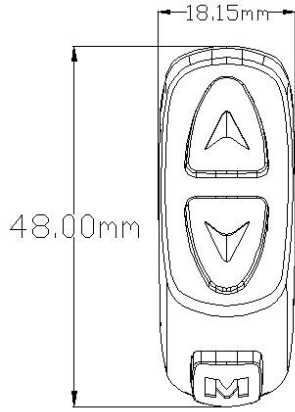

Switching view

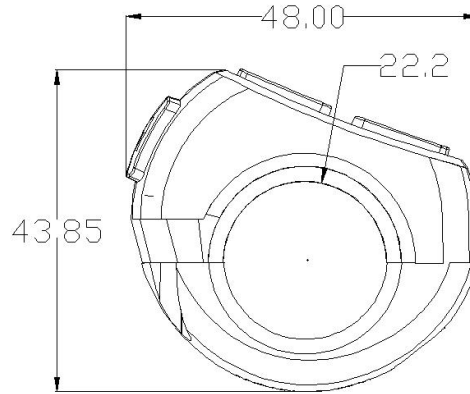

Switch Side View

## 二、 Work Voltage and connection mode

1、 Work voltage: DC24V 、 36V、 48V、 60V 、 (which you can choose on the meter),the others you can customized.

2、 Connection mode :

Line sequence of the label connector

### Instrument Outlet

Table: Line sequence of the label connector table

Order of line	Color of line	Function
1	Red (VCC)	Instrument power cord
2	Blue (K)	Controller power line
3	Black (GND)	Meter earth wire
4	Green (RX)	Meter data receiving line
5	Yellow (TX)	Data transmission line of instrument

**Notes: Part of the products lead wire use waterproof connection. User cannot see the color of lead line.**

## 三、 Function description

### 1、 Display function

Speed display, power level display, power indicator, failure warning, total mileage, single mileage, headlight display, single driving time display

### 2. Control, setting up functions

Power switch control, headlight switch control, 6Km/h point control, wheel diameter setting, maximum speed setting, idle automatic hibernation time setting, backlight brightness setting, voltage level setting

### 3.Communication protocol: UART

All the contents of the display screen(full display in boot 1S)

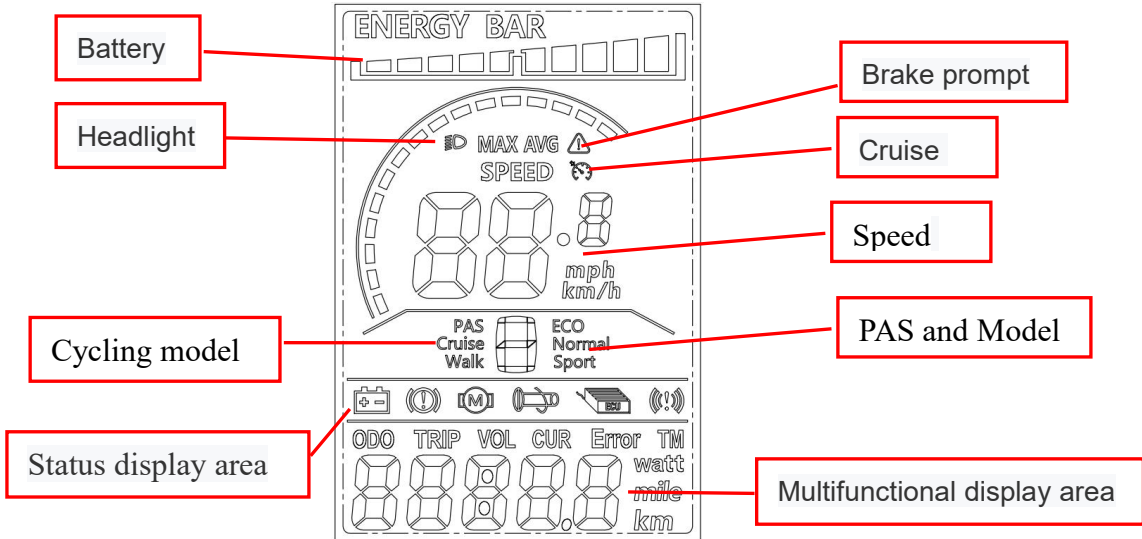

## Show content introduction

### 3.1 Headlight

The instrument can be manually turned on and the brightness of the sensing environment is automatically turned on(light sensitivity support is required).

### 3.2 Battery power display ENERGY BAR

### 3.3 Multifunctional display area ODO TRIP VOL CUR Error TM

Total mileage ODO, single mileage TRIP A, single mileage TRIP B, battery current voltage VOL, current operating current CUR, remaining mileage RM; Instrument boot time TM

### 3.4 Cycling model PAS Cruise Walk ECO Normal Sport

Walk boost mode; Cruise: constant speed cruise mode; PAS: Power file position: 0 ~ 9 adjustable;

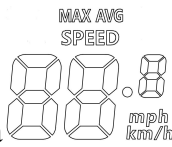

### 3.5 Speed display area

Maximum speed MAX, average speed AVG

Unit MPH, KM/H

The meter will calculate the true speed based on the wheel diameter and signal data

### 3.6 Vehicle Status Display Area

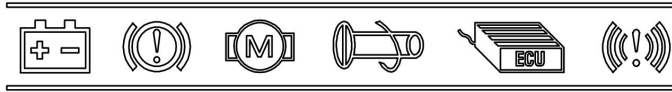

Meaning of fault icon:  Under-voltage fault

 Motor fault

 Controller the fault

 Turn the fault

 Communication failures

Status prompt icon:  Cruise ON

Vehicle Status Code Meaning:

Status Code(Decimal)	State Meaning	Remarks
E00	Normal	
E02	Brakes	
E06	Battery undervoltage	
E07	Motor failure	
E08	Turn malfunctioning	
E09	Controller failure	
E10	Communication reception failure	
E11	Communication dispatch failure	

### 3.7. install

**P01: Backlight brightness:** the darkest level 1, the brightest level 3;

**P02: mileage unit:** 0: KM; 1: MILE;

**P03: Voltage level:** 24V, 36V, 48V, 60V;

**P04: Dormancy time:** 0, not dormancy; Other numbers are dormancy times, range: 1-60; Unit minutes;

**P05: PAS number selection:** 0, 3 file mode:

1,5 gear mode:

**P06: Wheel setting:** unit, inch;

wheel diameter value: 5.0 ~ 50 Precision: 0.1 inch

This parameter is related to the meter display speed and needs to be entered correctly;

**P07: Speed gauge magnetic steel number:** range: 1-100;

This parameter is related to the meter display speed and needs to be entered correctly;

If it is an ordinary hub motor, the number of magnetic steel is input directly;

If it is a high-speed motor, it is also necessary to calculate the deceleration ratio, and the input data = the number of magnetic steel × deceleration ratio;

For example: number of motor magnets 20, deceleration ratio 4.3: input data is:  $86 = 20 \times 4.3$

**P08: Speed limit setting:** Agreement No. 2 range 0-100km / H, 100 means no speed limit;

The input data here represents the maximum operating speed of the vehicle: for example, input 25, indicating that the maximum operating speed of the vehicle will not exceed 25km/h; The drive speed is maintained at the set value,

Error:  $\pm 1$ km/h; (The speed limit for power and turning is equal)

Note: The value here is based on kilometers. When the unit setting is converted from kilometers to miles, the speed value of the display interface automatically converts to the correct mile value, but the speed limit value data set at this menu under the mile interface is not converted. Is inconsistent with the actual speed limit of the mile speed;

**P09: zero start, non-zero start setting:** 0: zero start; 1: Non-zero start;(valid for protocol 2 only)

**P10: The drive mode is setting:** 0: Power Drive(how much power is output is determined by the power file bit, and the switch is invalid at this time).(valid for protocol 2 only)

1: Electric drive(by turning the handle drive, the power file bit is invalid at this time).

2: Power Driven and Electric Driven Coexistence

**P11: Help sensitivity setting:** range: 1-24;(valid for protocol 2 only)

**P12: Help start intensity setting:** range: 1-5;(valid for protocol 2 only)

**P13: Power Magnetic Steel Disk Type Setting:** 5, 8, 12 Magnetic Steel Types

**P14: Controller limit value setting:** range: 1-20A

**P15: Controller undervoltage**

**P16: ODO zero setting:** length press key 5 seconds ODO zero

**P17 :Automatic cruise optional:** 0: No enabling cruising, 1: enabling cruising; (valid for protocol 2 only); (valid for protocol 2 only)

**P18: Display speed ratio adjustment:** range: 50 % ~ 150 %,

**P19:Zero PAS selection:** 0: 0 file, 1: does not include 0 file

**P20 :0:2 Protocol 1:5 S Protocol 2: Standby 3: Standby**

#### 四、Key Introduction:



The specific combination of keys is as follows



Press the button to use the brief

Key operation is divided into short press and long press, and combination key length press

Short press is used for rapid/frequent operations, such as the specific key combination position as follows

1.   When riding, you need to modify the power/speed file, short press

2.  Toggle display data for multi-function areas during cycling, short click

Single key length is mainly used to switch the mode / switch state

Composite keys(long presses) are used to set parameters because the operation is complex, which can reduce errors

(Short press does not make the composite key, because it is easy to trigger mistakenly, so it is too difficult to do)

Specific operational explanations:



一, modify the power ratio / power file

Let's say the current is power mode.

- 1) Short press , Help + 1

- 2) Short press , Help - 1

二, Toggle speed display

Long press,  +  Toggle speed display

### 三, Set / Disable 6Km/h Cruise, Switch Headlight, ODO Clear Zero

Static state of vehicles, long press , Will enter 6KM/h cruise mode, let go of cruise

mode; long press  Turn the lights on and off;

P16 Menu Interface, long press  five seconds, ODO clear zero.



### 四, Switching liquid crystal display

If the current display is working, long press , Will turn off the screen, instead turn on the screen



### 五, Toggle multi-function display area content

Short  Can switch the value of the multifunction display area

### 六, Set Parameters

Long press  +  Will enter the parameter setting interface. Parameters that can be set include, Wheel diameter (in: inches), number of magnetic steel, liquid crystal brightness, low pressure points, etc. (see settings: P01-P20);

Under Settings Interface, Can be short press , or  Set the value to perform a

minimum-precision unit value operation, you can also long press , or 

Continuous Fast Modify Parameters:

1.Short press  Switch to Next Parameter; Exit settings and save parameters. If not operated, the modified parameters will automatically exit and be saved after 8 seconds.

**Note: due to the upgrade of the company's products, the content of the product will be different from the specifications, but it will not affect your normal use.**

**Address:** Room 1011, Building B, 213 Yulong South Road, Zhonglou Economic Development Zone, Changzhou City, Jiangsu Province