

UX-52 MCU control multi-function Digital display Motor Speed  
400W AC220V Pinpoint Regulator Controller  
Forward&Backward 50/60hz

---



The parameters

параметр

**Dear customers, please note before buying:**

1. First of all, please confirm whether your motor is adjustable motor (because many induction motors have fixed speed and are not suitable for speed regulation)
2. We recommend the governor to be matched with the adjustable speed induction motor shown below.
3. If the customer uses other motor speed regulation, we do not guarantee that it can work normally, once it cannot work normally, we support the return, but we refuse disputes!





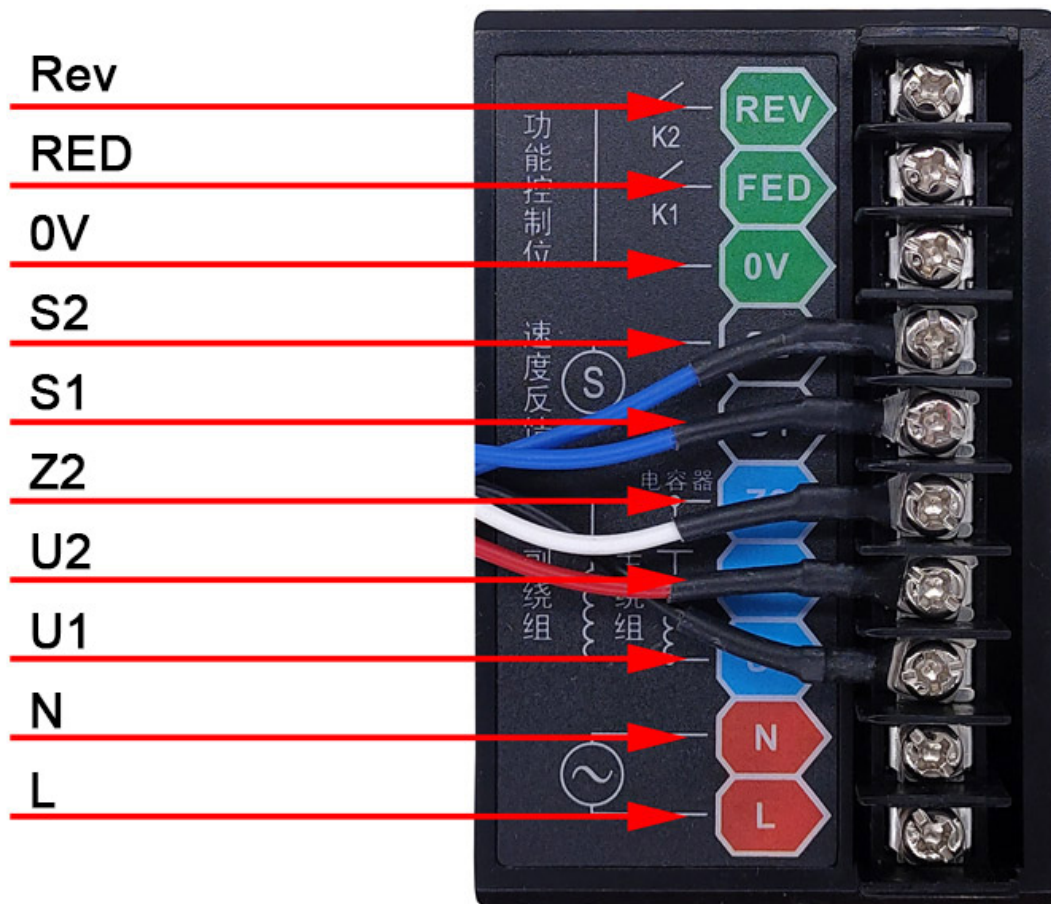



# Panel-Based Speed Controller/Governor Operating Instructions

## ◆Features:

- USE MCU digital control technology, with rich functions and excellent performance.
- USE Digital display menu option, which is convenient and fast to modify the setting.
- The display magnification can be set according to the user's display needs, and the display target value can be automatically converted.
- It can realize slow acceleration and slow deceleration.
- It can be operated by panel and controlled by external switch.
- The panel button automatically matches the maximum speed, which is convenient and safe to adjust and control. (This function can protect locked rotor overload, but it cannot protect non locked rotor overload.)
- Add cycle operation function.

## ◆Wiring Diagram of Panel-Based Speed Controller/Governor:

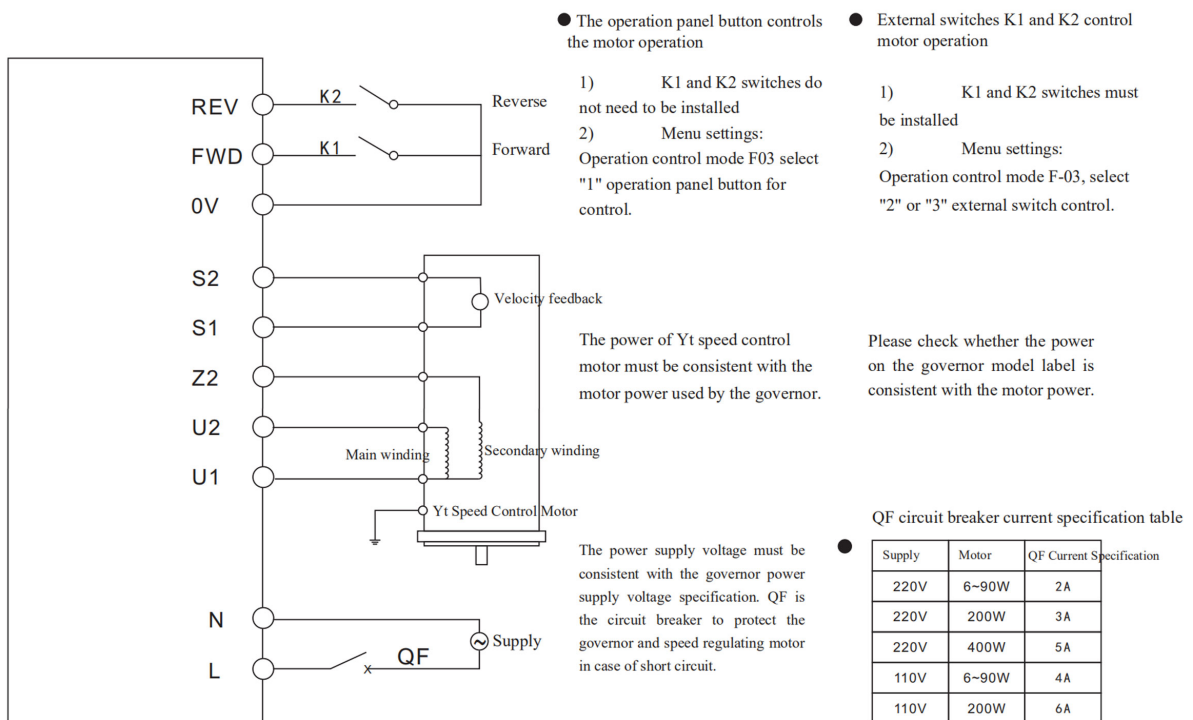

Menu setting: Long press the MODE key and press ▲▼ to select a parameter, and press ENTER to display the set value, and repeat the previous steps to set other parameters, and press MODE to exit.

Parameter Code	Parameter Functions	Setting Range	Functional Specification	Default
F-01	Show contents	1. Motor speed setting 2. Setting value of magnification 3. Display speed feedback value	Magnification setting value = motor speed setting value ÷ magnification	1
F-02	Magnification setting	1. 0-999.9	Set according to the needs of visual display and display the target value.	1.0
F-03	Operation control mode	1. Operation panel button control, no memory 2. External switch control, stop key is invalid 3. External button control, stop key is valid 4. Operation panel button control with memory	Select "1" To control the motor by the panel button, turn off the power supply of the governor and then power on. The governor remembers the running state before power off, and the motor is stopped when it is powered on again. Select "4" To memorize the running state before power off, and re power on the motor to the state before power off last time. Select this function and pay attention to safety! Note: The working state is not saved during recirculation operation.	1
F-04	Operation mode	1. Forward and reverse rotation are allowed 2. Forward rotation is allowed and reverse rotation is prohibited 3. Reverse rotation is allowed and forward rotation is prohibited	Limit the rotation direction of the motor to prevent equipment failure or accident. Setting is allowed only when the motor is stopped	1
F-05	Reverse rotation direction	1.No reversion 2. Reversion	Without changing the motor wiring, it is easy to change the motor direction to make it consistent with habits or requirements.	1
F-06	Adjustment mode of speed governing	1. Panel ▲▼ buttons 2. Panel buttons	Press ▲▼ buttons in the range of minimum to maximum speed, and the speed panel button of speed regulating motor will automatically match the minimum speed and maximum speed.	2
F-07	Maximum speed	500-3000	Limiting the maximum speed of the motor can prevent overspeed, damage or accident.	1400
F-08	Minimum speed	90-1000	Limiting the minimum speed of the motor can prevent the motor from unstable speed, overheating and overload due to low speed.	120
F-09	Acceleration time of forward start	0.1-10.0s	If the time is long, the motor starts smoothly and the starting time is long. If the time is short, the motor starts quickly and violently, and the starting time is short.	0.3
F-10	Stop mode of forward rotation	1.Free deceleration stop 2. Slow deceleration stop	When free deceleration stop is selected, if the motor stops quickly, slow deceleration stop can be selected. Change the F-11 setting value to change the speed of slow deceleration stop.	1
F-11	Slow deceleration time of forward rotation stop	0.1-10.0s	When F-10 selects 2, the menu is valid.	0.1
F-12	Acceleration time of reverse start	0.1-10.0s	If the time is long, the motor starts smoothly and the starting time is long. If the time is short, the motor starts quickly and violently, and the starting time is short.	0.3
F-13	Reverse time mode	1.Free deceleration stop 2. Slow deceleration stop	When free deceleration stop is selected, if the motor stops quickly, slow deceleration stop can be selected. Change the F-14 setting value to change the speed of slow deceleration stop.	1
F-14	Slow deceleration time of reverse stop	0.1-10.0s	When F-13 is selected, the menu is valid.	0.1
F-15	Alarm enable	1. Valid alarm 2. Invalid alarm	Control whether the locked rotor warning is effective	1
F-16	Cyclic rotation enable	1.Invalid 2.Valid	Control whether the motor cycle function is effective When it is set to 2, it starts rotation after receiving a valid start direction signal	1
F-17	Number of turns	1-9999s	Control motor rotation times	2
F-18	Forward rotation time	0-9999s	Set the forward rotation time When set to 0, it means that the cycle operation does not carry out forward rotation	5
F-19	Reverse rotation time	0-9999s	Set the forward rotation time When set to 0, it means that the cycle operation does not reverse	5
F-20	Operation interval	1-9999	Set the forward and reverse switching or one-way intermediate interval time	5
F-21	Forward velocity	90-3000	Set the operating speed in the forward direction of the cycle	1000
F-22	Reverse velocity	90-3000	Set the operating speed in the reverse direction of the cycle	1000
F-23	Factory reset	1. Do not restore factory settings 2. Restore factory settings		1

Notes:

Fault alarm err: 1) overload locked rotor

2) the connecting line between the governor and the motor is abnormal

Troubleshooting methods: 1) check and troubleshooting

2) reconnect the power for disarming the alarm

Underlined items can be modified only in the stopped state.

# SPEED CONTROL UNIT

