

Applications

-Multifunction time relay can be used for electrical appliances, control of lights, heating, motors, pumps and fans (10 functions, 10 time ranges, multi-voltage).

Feature

- 10 functions:
 - 5 time functions controlled by supply voltage
 - 4 time functions controlled by control input
 - 1 function of latching relay
- Comfortable and well-arranged function and time-range setting by rotary switches.
- Time scale 0.1 s - 10 days divided into 10 ranges.
- Relay status is indicated by LED.
- 1-MODULE, DIN rail mounting.

Model and connotation

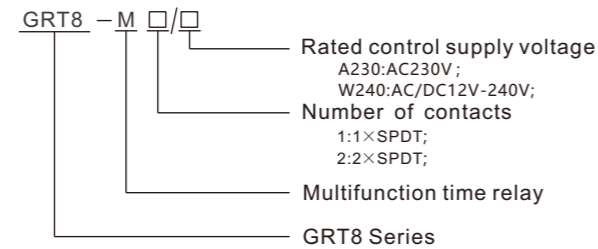

Technical parameters

	GRT8-M1	GRT8-M2
Function	A,B,C,D,E,F,G,H,I,J	
Supply terminals	A1-A2	
Voltage range	AC/DC 12-240V(50-60Hz)	
Burden	AC 0.09-3VA/DC 0.05-1.7W	
Voltage range	AC 230V(50-60Hz)	
Power input	AC max.6VA/1.3W	AC max.6VA/1.9W
Supply voltage tolerance	-15%;+10%	
Supply indication	green LED	
Time ranges	0.1s-10days,ON,OFF	
Time setting	potentionmeter	
Time deviation	10%-mechanical setting	
Repeat accuracy	0.2%-set value stability	
Temperature coefficient	0.05%/°C,at=20°C(0.05%/°F, at=68°F)	
Output	1xSPDT	2xSPDT
Current rating	1x16A(AC1)	2x16A(AC1)
Switching voltage	250VAC/24VDC	
Min.breaking capacity DC	500mW	
Output indication	red LED	
Mechanical life	1x10 ⁷	
Electrical life(AC1)	1x10 ⁵	
Reset time	max.200ms	
Operating temperature	-20°C to +55°C (-4°F to 131°F)	
Storage temperature	-35°C to +75°C (-22°F to 158°F)	
Mounting/DIN rail	Din rail EN/IEC 60715	
Protection degree	IP40 for front panel/IP20 terminals	
Operating position	any	
Overvoltage cathegory	III.	
Pollution degree	2	
Max.cable size(mm ²)	solid wire max.1x2.5or 2x1.5/with sleeve max.1x2.5(AWG 12)	
Dimensions	90x18x64mm	
Weight	1xSPDT: W240-62g,A230-60g 2xSPDT: W240-82g,A230-81g	
Standards	EN 61812-1,IEC60947-5-1	

Functions Diagram

A:On Delay (Power On)

When the input voltage U is applied, timing delay t begins. Relay contacts R change state after time delay is complete. Contacts R return to their shelf state when input voltage U is removed. Trigger switch is not used in this function.



B:Interval (Power On)

When input voltage U is applied, relay contacts R change state immediately and timing cycle begins. When time delay is complete, contacts return to their shelf state. When input voltage U is removed, contacts will also return to their shelfstate. Trigger switch is not used in this function.

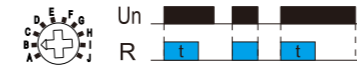

C:Repeat Cycle (Starting Off)

When input voltage U is applied, time delay t begins. When time delay t is complete, relay contacts R change state for time delay t. This cycle will repeat until input voltage U is removed. Trigger switch is not used in this function.



D:Repeat Cycle (Starting On)

When input voltage U is applied, relay contacts R change state immediately and time delay t begins. When time delay t is complete, contacts return to their shelf state for time delay t. This cycle will repeat until input voltage U is removed. Trigger switch is not used in this function.

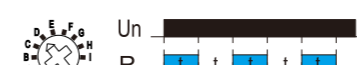

E:Off Delay (S Break)

Input voltage U must be applied continuously. When trigger switch S is closed, relay contacts R change state. When trigger switch S is opened, delay t begins. When delay t is complete, contacts R return to their shelf state. If trigger switch S is closed before time delay t is complete, then time is reset. When trigger switch S is opened, the delay begins again, and relay contacts R remain in their energized state. If input voltage U is removed, relay contacts R return to their shelf state.

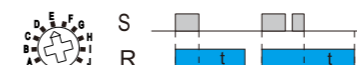

F:Single Shot

Upon application of input voltage U, the relay is ready to accept trigger signal S. Upon application of the trigger signal S, the relay contacts R transfer and the preset time t begins. During time-out, the trigger signal S is ignored. The relay resets by applying the trigger switch S when the relay is not energized.

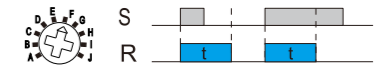

G:Single Shot Trailing Edge (Non-Retriggerable)

Upon application of input voltage U, the relay is ready to accept trigger signal S. Upon application of the trigger signal S, the relay contacts R transfer and the preset time t begins. At the end of the preset time t, the relay contacts R return to their normal condition unless the trigger switch S is opened and closed prior to time out t (before preset time elapses). Continuous cycling of the trigger switch S at a rate faster than the preset time will cause the relay contacts R to remain closed. If input voltage U is removed, relay contacts R return to their shelf state



H:On/Off Delay

Input voltage U must be applied continuously. When trigger switch S is closed, time delay t begins. When time delay t is complete, relay contacts R change state and remain transferred until trigger switch S is opened. If input voltage U is removed, relay contacts R return to their shelf state.



I:Latching relay

Input voltage U must be applied continuously. Output changes state with every trigger switch S closure. If input voltage U is removed, relay contacts R return to their shelf state.



J:Pulse generator

Upon application of input voltage U, a single output pulse of 0.5 seconds is delivered to relay after time delay t. Power must be removed and re-applied to repeat pulse. Trigger switch is not used in this function.

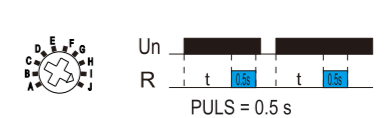

Time Range

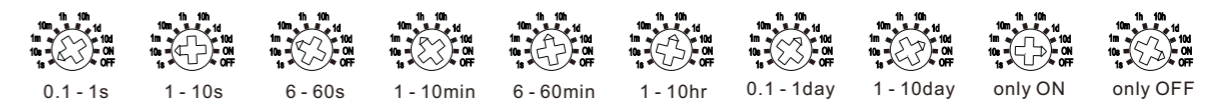

Wiring Diagram

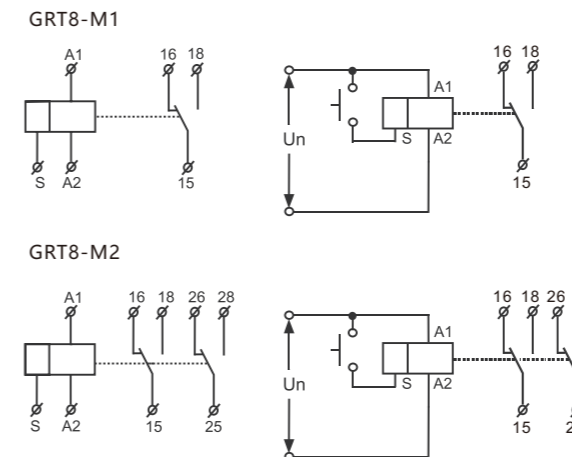

Dimensions(mm)

