

Digital PID Temperature Controller Thermostat REX-C100 + Max 40A SSR SSR-40DA Relay + K Thermocouple M6 1M Probe with Heat Sink

REX-C100 K Type
+K Thermocouple 1m
+Heat Sink(10-40A)
+SSR 40DA



[REX-C100 REX-C100FK02-V*AN Digital PID Temperature Control Controller SSR Output 0-400 Degrees Universal K PT100 J Type Input](#)USD 6.14/piece

[PID Digital Temperature Controller REX-C400 Universal Input Relay SSR Output for Automatic Packing Machine Thermostat](#)HotUSD 6.85/piece

[Dual Digital PID Temperature Controller REX-C100 Universal Input SSR Relay Output + M6 Probe 1m cable K type thermocouple](#)HotUSD 11.39/piece

[220V PID Temperature Controller REX-C900 Thermocouple PT100 K Universal Input Multi-input SSR Relay Output Thermostat](#)RegularUSD 7.28/piece

AC 220V Oven Temperature Controller REX-C700 C700 Thermocouple PT100,K Universal Input Relay Output 72*72mm ThermostatUSD 6.85/piece

Digital PID Temperature Temp Controller RKC REX-C410 48*96mm Horizontal, Input thermocouple K,PT100,J Relay Output for heatUSD 13.37/piece

Digital PID Temperature Controller Thermostat REX-C100 + Max 40A SSR SSR-40DA Relay + K Thermocouple M6 1M Probe with Heat SinkUSD 6.89-22.68/piece

New Digital PID Temperature Controller Thermostat REX-C100 + Max 40A SSR SSR-40DA Relay + K Thermocouple M6 Probe High Quality

Model No:REX-C100FK02-V*DA

Range: 0 to 400 °c K

Output:SSR

Supply:100-240VAC 50/60HZ

AC contactor:18A(Default 220V)

K Thermocouple Probe Cable

1.Length: 1M

2.Sensor diameter:5mm

3.Temperature rang :0-400

4.Internal Insulation: Fiberglass

5.External Shielding: Insulated Shielding

User manual

First of all, thank you for using our company's products. This series of products is based on the most advanced modern control theory, microcomputers controlled by microcomputers and a smart temperature control instrument with PID self tuning (automatic optimization) function. Please read the instructions in detail before use.

1. Model description

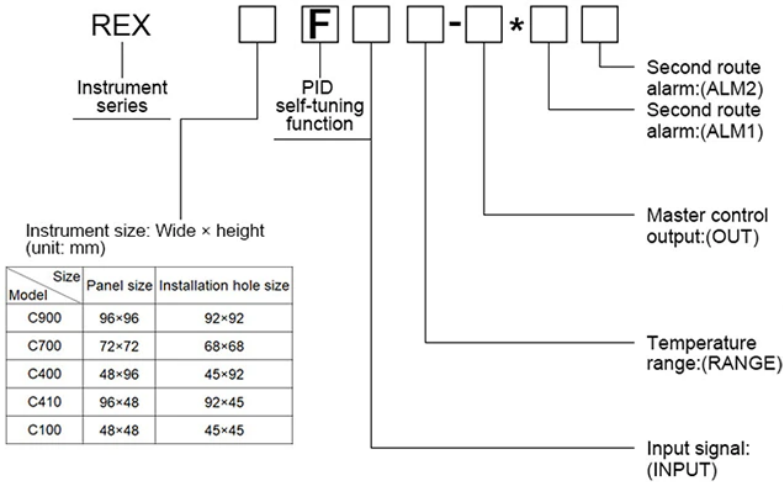

Please refer to the first way to the police

- N-no alarm.
- E-error upper limit alarm
- F-error lower limit alarm
- H-absolute upper limit alarm
- L-absolute lower limit alarm
- M-relay contact output(RELAY)
- V-contactless voltage pulse output
- Drive solid state relay SSR
- 8-DC current 4~20mA output
- G-Phase shift pulse output, thyristor
- g-zero pulse output, thyristor
- 02 is 0-400 degrees centigrade
- 05 is 0-999 degrees centigrade
- 06 is 0-1200 degrees centigrade
- 07 is 0-1372 degrees centigrade
- 08 is 0-1600 degrees centigrade
- K-K type thermocouple
- J-J type thermocouple
- S-S type thermocouple
- D-Pt100 thermal resistance

Example:C100FK02-V*EN

The instrument should be: the size of the panel is 48 X 48; it has PID self setting function; with K thermocouple; temperature range of 0-400°C;contactless voltage pulse output (driving solid state relay SSR); the first alarm for the upper limit of deviation alarm; no second road alarm.

2. Panel name and its functions



NO	Panel description	Content description
1	PV	Measured value / pattern display value
2	SV	Set value / Mode content display value
3	OUT1	Output 1 Indicator lamp
4	OUT2	Output 2 Indicator lamp
5	AT	PID automatic indicator lamp
6	ALM1	Alarm 1 indicator lamp
7	ALM2	Alarm 2 indicator lamp
8	▲	Add keys
9	▼	Reducing key
10	◀	Displacement key
11	SET	Setting, pattern key

3. Operation process

3.1 Opening process

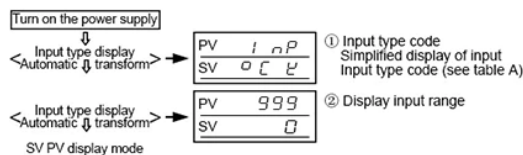

3.2 SV setting mode

In the normal display state of SV/PV, press the "SET" key, make SV display in the flicker state, by pressing the "<" key, find the number of required temperature, and then press the rise or drop key, set to the required temperature value, after setting, again press a "SET" key, so that the instrument to SV/PV normal display state.

3.3 Parameter setting mode

This parameter is used to set alarm, PID constant and other parameters. In the normal display state, after holding the "SET" key for three seconds, the parameter setting state is displayed in the PV display, the corresponding value is displayed in the SV display, and the lower table parameter symbol is displayed in turn according to the "SET" key.

Note: This machine has an automatic response function. The instrument automatically returns to the main display mode after 30 seconds when the operator forgets to return to the main display mode by setting parameters and modifying operations. Read the following contents before using or modifying parameters. The contents of the following processes, such as meters without this function, will not display this content.

4. Main menu

After the instrument is energized, press the SET key for about 2 seconds to enter the main menu.

Display character	Parameters	Default value	Adjustable range	Explain
S U	SV	100	SLL-SLH	Set value
R L !	AL1	10	SLL-SLH	Alarm value (AC1=0 does not display)
R F !!	AT	0	0-1	Self-tuning 0-closes 1-open

Measurement range of various types of sensors

Display character	Parameters	Adjustable range
b	B	500~999(Customized)

P	P	30	0-999	Proportions
OH	OH	2	1-100	Main control return (P=0)
I	I	120	0-999	The integral term (P=0 does not display)
d	D	30	0-999	The differential term (P=0 does not display)
Ar	Ar	80	0-100	Integral overshoot suppression (P=0 does not display)
T	T	20	1-100	The cycle (P=0 does not display)
SC	SC	0	-199-199	Sensor correction value
LCK	LCK	0	0-111(BIN)	Password lock: 000(Bin) All parameters can be modified 001(Bin) SV AL1 AL2 modifiable 011(Bin) SV modifiable 111(Bin) All non modifiable All other can not be modified

5. Instrument Engineer parameter menu

After the instrument is energized, the "SET" key is pressed down with the "two" key at the same time. After about 3 seconds, the "Cod" is displayed in the PV display. In the "Cod" =001, press the "SET" button in turn to get and display the following parameters circularly:

Display character	Parameters	Default value	Adjustable range	Explain
SN	SN	K	B,S,R,T,K,N,J,E,PT,Cu	Graduation
SLL	SLL	-50	Sensor corresponding measurable range	Display lower limit
SLH	SLH	999	Sensor corresponding measurable range	Display upper limit
SUL	SUL	-50	The set value corresponds to the settable range	Display lower limit
SUH	SUH	999	The set value corresponds to the settable range	Display upper limit
OD	OD	0	0-1	Control mode:0-heating 1-refrigeration
OUK	OUK	0	0-1	Output mode:0-switch 1-continuous (1-SV or 4-20mA needs corresponding module support)
AC1	AC1	1	0-6	AL1 alarm mode : 0- without alarm 1 up deviation alarm 2 lower deviation alarm 3 up and down deviation alarm 4 up and down deviation internal alarm 5 process value upper limit alarm 6 process value lower limit alarm
AC2	AC2	0	0-6	AL1 alarm mode : 0- without alarm 1 up deviation alarm 2 lower deviation alarm 3 up and down deviation alarm 4 up and down deviation internal alarm 5 process value upper limit alarm 6 process value lower limit alarm
AH1	AH1	2	1-100	1 error of alarm
AH2	AH2	2	1-100	2 error of alarm
UNIT	UNIT	0	0-1	Unit: 0-°C 1-°F
DF	DF	50	0-100	Filter coefficient
COT	COT	0.4	0.00-10.0	Display inhibition
FAC	FAC	0	0-100 Overtemperature display limit	0-shutoff function Other values, beyond the set value. The portion of the excess is displayed proportionately Display value = SV + (PV - SV)/FAC

When the Cod is changed to 911, the factory value menu can be restored.

S	S	-50~999(Customized)
r	R	-50~999(Customized)
t	T	-50~999(Customized)
đ	K	-50~999
n	N	-50~999
đ	J	-50~999
E	E	-50~800
PT	PT100	-50~800(Customized)
Cu	Cu50	-50~150(Customized)

6. Error display function

When the meter does not work properly, the instrument will display message prompts after self diagnosis.

Message	Explain	Elimination method
Err	Instrument failure	Please send and repair
ooo	Input broken line, polarity connection or beyond the input range	Please check whether the input signal is wrong
uuu	Input broken line, polarity connection or beyond the input range	Please check whether the input signal is wrong

7. Matters of attention

1. Check whether the instrument graduation number and power supply voltage are the same as the instrument.
2. Correct wiring according to the wiring diagram.
3. For thermocouple input signal, please use compensating wire with the same material as thermocouple wire.

4. For the thermal resistance input signal, use the same specification of low resistance wire, and the three line. The length is the same as possible.

*5. Pay special attention to the power input line and sensor signal input line can not be confused. Otherwise, the whole instrument is burnt out and can not be repaired. The output terminal can not be strong, The current is short circuited.

6. the instrument power line and signal line should be separated from the high current output line as far as possible. The effect of less electromagnetic radiation on instruments is unavoidable. Select the shield line.

7. When ordering, please note:

- ① Instrument model
- ② Distribution number of sensor
- ③ Instrument output type
- ④ Measuring range
- ⑤ Other special technical and functional requirements.

8. WARNING

The product is strictly inspected before the factory is out of the factory, such as the product itself that has the right of responsibility for one year because of the quality problems, and does not bear any other joint liability. Damage caused by self dismantled or improper use is not within the scope of warranty.

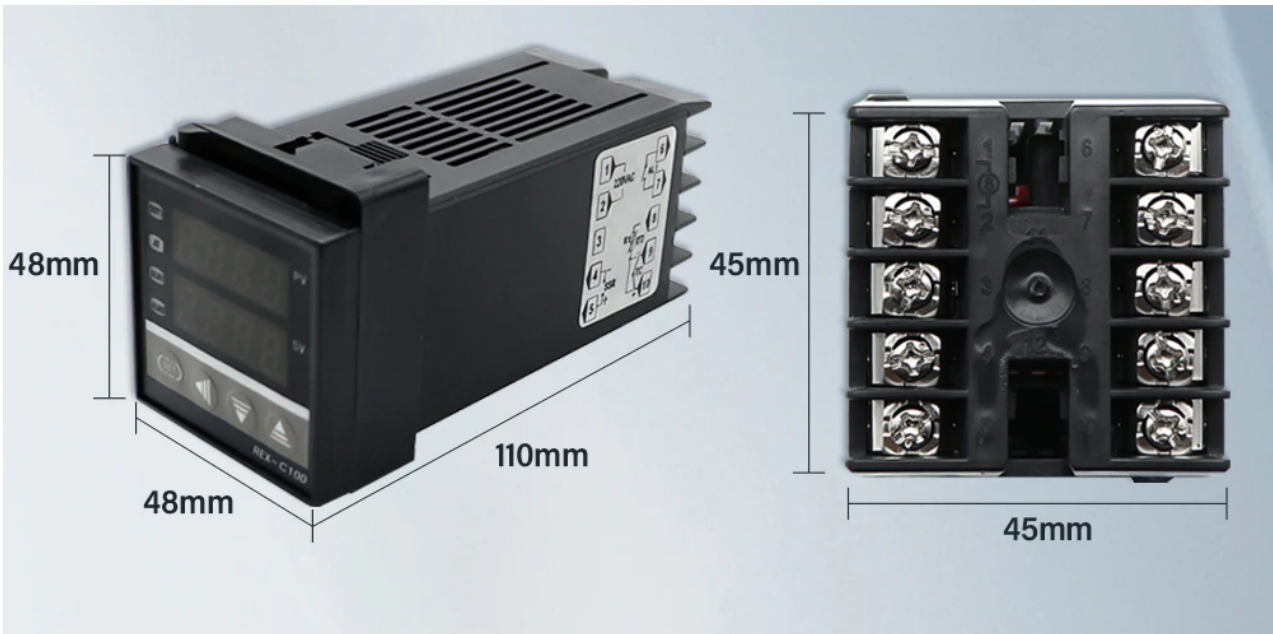

Basic Product Information | Intelligent Temperature Controller



Product Model: Rex Series

Working Voltage: 100-240V AC 50hz / 60hz

Input Method: K,

Output Mode: Relay Solid State Relay (Ssr) Optional

Alarm Range: Full Range Free Setting

Main Function: Temperature Control And Constant Temperature

Service Environment: 0 ~ 50°C, 30 ~ 85% Rh Non Corrosive Gas Occasions

Insulation Strength: 1500vac / Min

10A - 40A

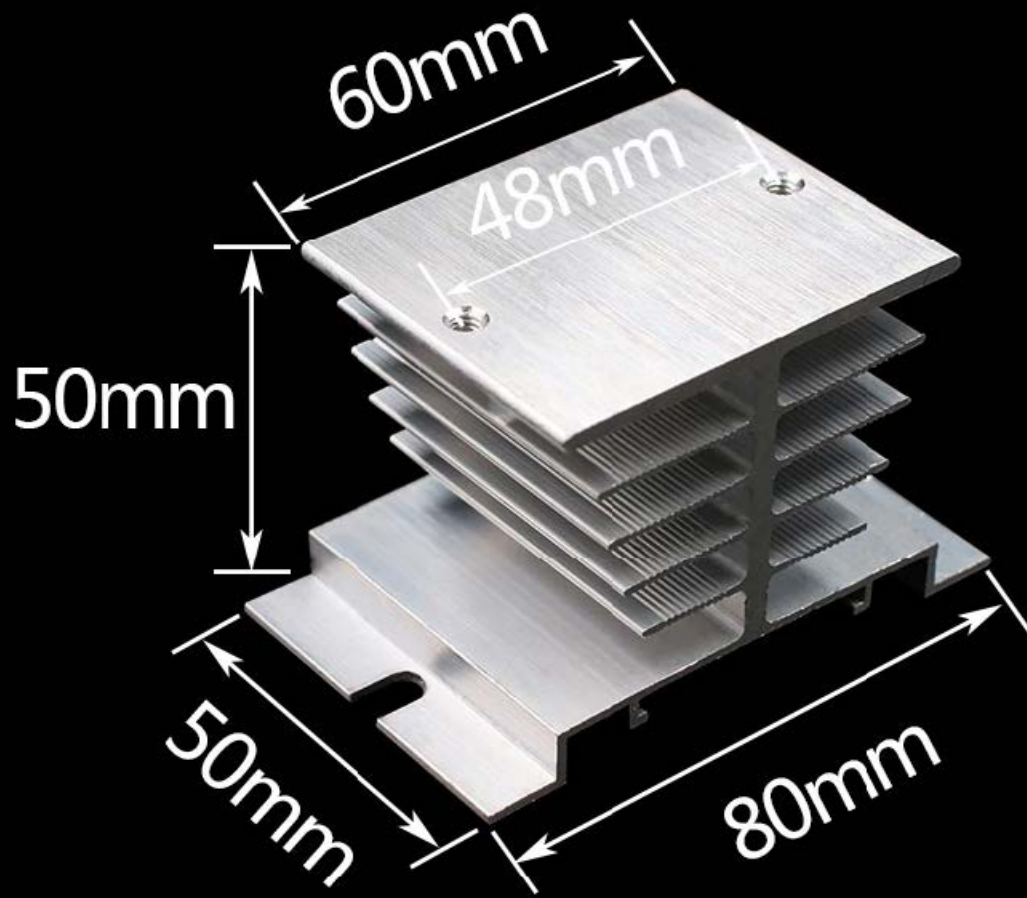



DC Control AC

Model	Load Current	Control Voltage	3-32VDC	Shut-off Voltage	$\leq 1.5\text{VDC}$
SSR-10DA	10A	Load Voltage Range	24~380VAC	Control Current	$< 25\text{mA}$
SSR-25DA	25A			Starting Current	5mA
SSR-40DA	40A			Insulation Voltage	$\geq 2500\text{VAC}$
SSR-60DA	60A	Cooling Condition	10-30A With Radiator	On-off Time	$\leq 10\text{MS}$
SSR-80DA	80A		40-300A Add fan for forced cooling	Work Instructions	LED
SSR-100DA	100A	Load Current	Resistive load 35%	a fixed way	Bolted
			Inductive load 20%	On-state pressure drop	$\leq 1.5\text{V}$
		Ambient Temperature	-25~+75°C	On-state leakage current	$\leq 2\text{mA}$
				Insulation Resistance	100M Ω /500VDC

Optional Voltage

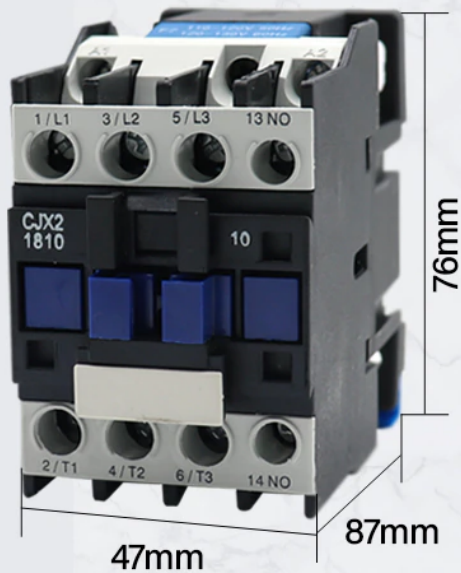

Name: Ac Contactor

Model: CJX2-1810

Current Specification: 18A

Rated Frequency: 50hz

Coil Voltage: Multi Specification Optional

Operating Frequency: 1200 Times/h

Wiring Capacity: 4-10mm²

Ambient Temperature: -5°C-40°C

Operating Altitude: ≤2000m

Protection Grade: IP20

SCREW THERMOCOUPLE

M6

- High Precision Shielded Wire
- Sensitive Thread Probe
- Accurate and Stable Temperature Measurement



K Tepy

Easy And Fast Installation

First Tighten The Connecting Bolt On The Measured Object, Then Close The Thermocouple To The Measured Object And Tighten The Ferrule Screw



Measured Object



*Wiring nose
Connect the thermostat*



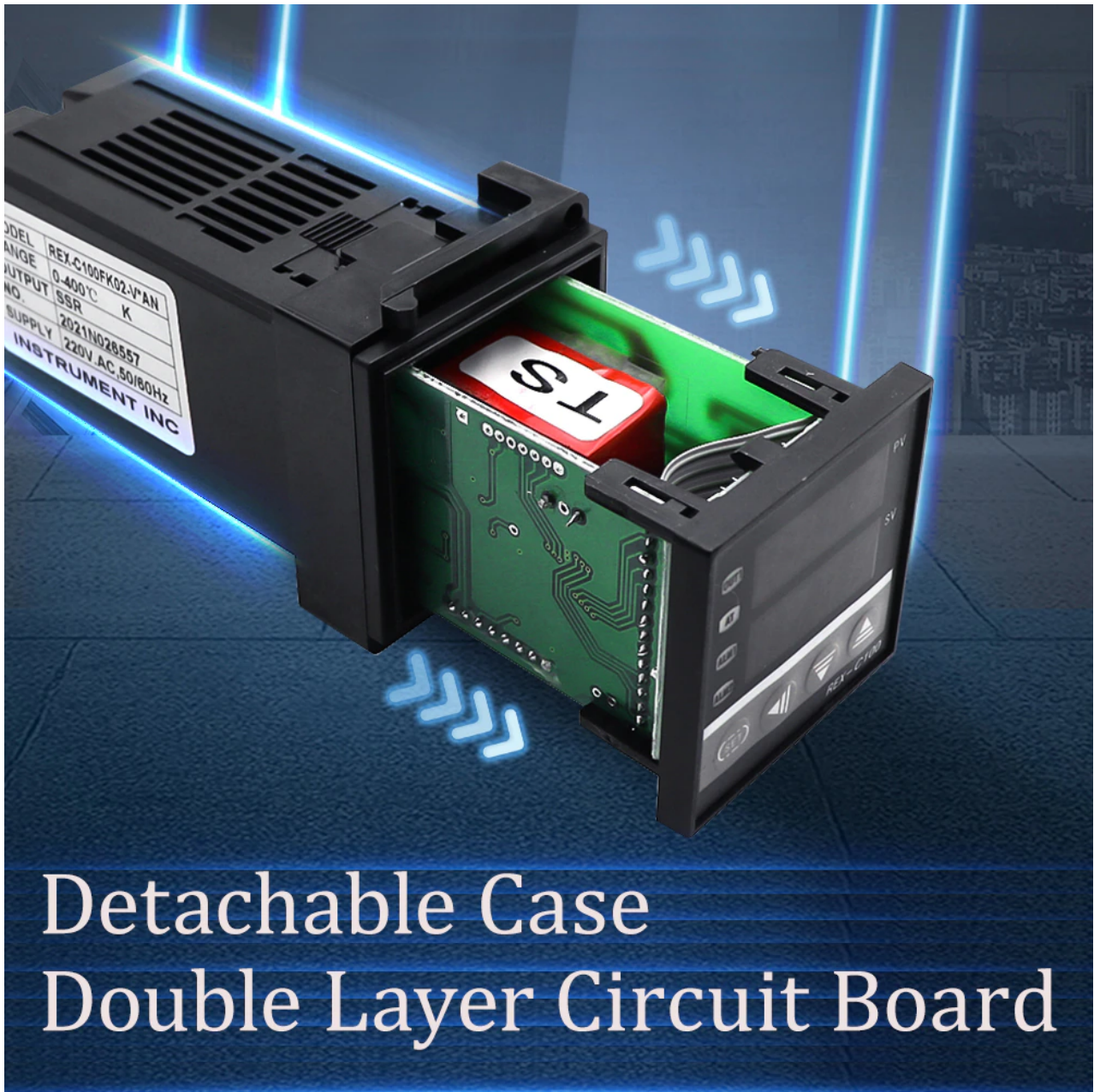

Relay Output

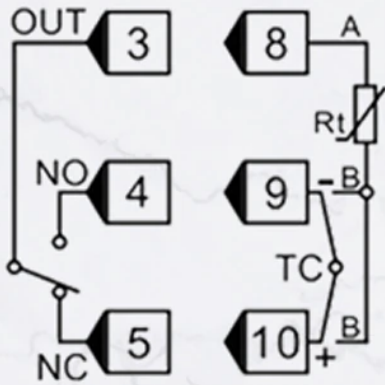
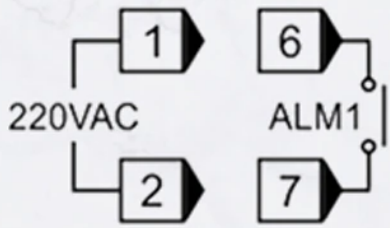

SSR Output

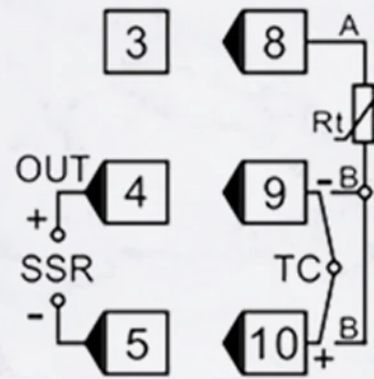
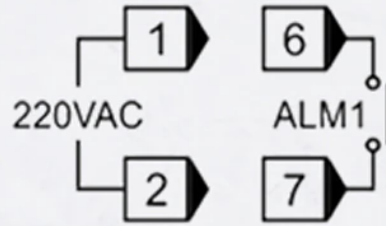

Relay Wiring Diagram

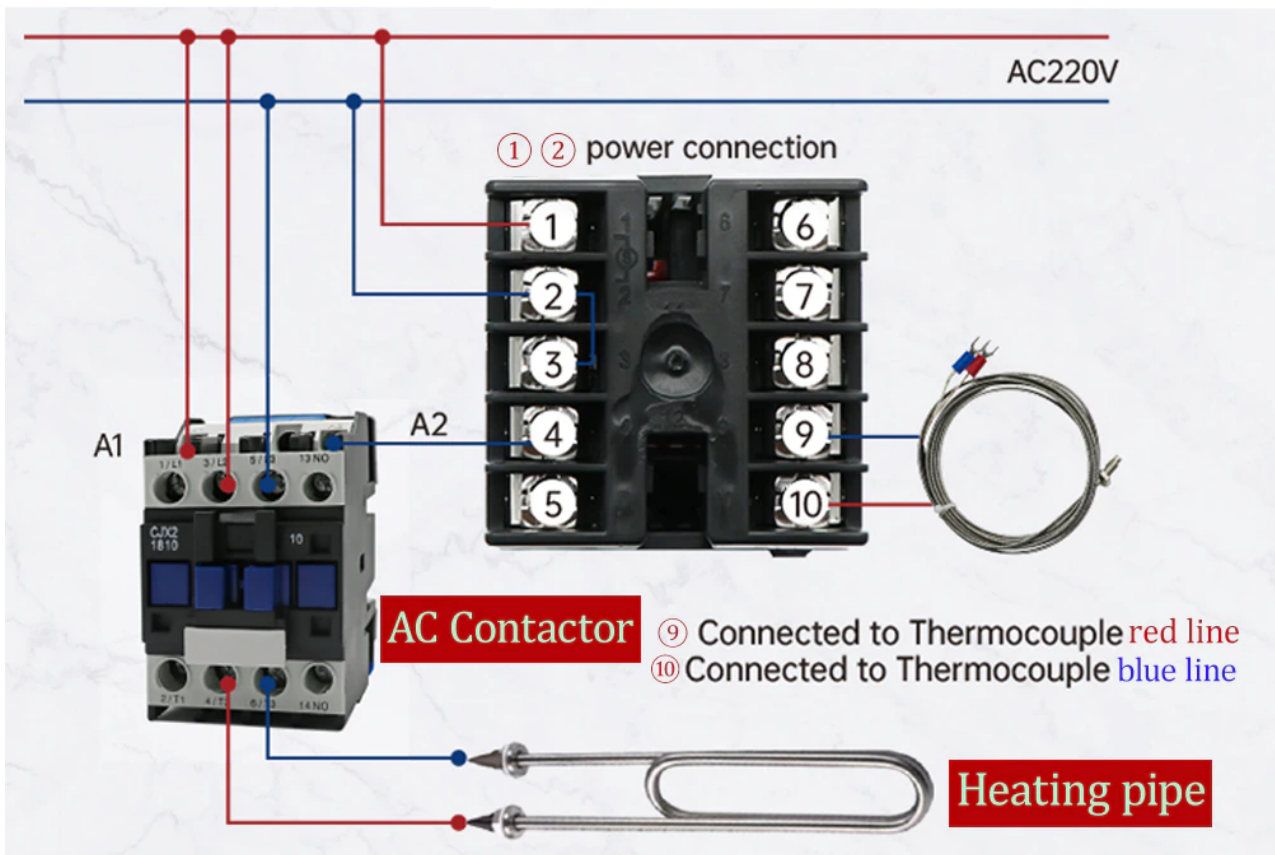

Note: The thermal resistance (PT100/Cu50) has three wires, the red wire is connected to ⑧, and the other two wires are connected to ⑨ and ⑩ at will.

SSR Wiring Diagram

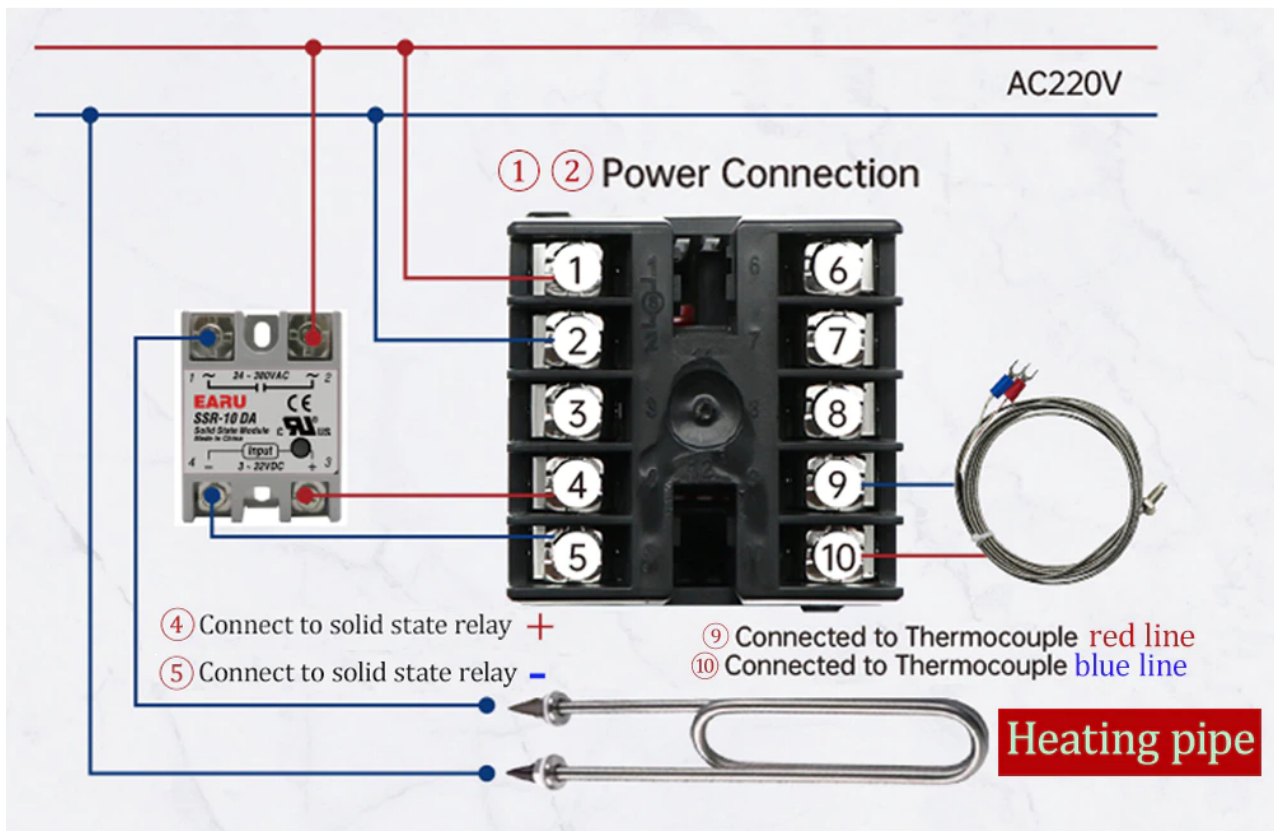

Note: The thermal resistance (PT100/Cu50) has three wires, the red wire is connected to ⑧, and the other two wires are connected to ⑨ and ⑩ at will.