

QUICK START GUIDE

LYNX

CYKE



VISIT OUR CHANNEL FOR THE
ASSEMBLY GUIDE VIDEOS

**THIS QUICK START GUIDE IS NOT A REPLACEMENT FOR THE CYKE OWER'S MANUAL.
THE COMPLETE CYKE OWER'S GUIDE CONTAINS OTHER IMPORTANT INFORMATION
ABOUT YOUR BIKE.**

You can download a range of manual and answers or information on question you may have
at [cykebikes.com](https://www.cykebikes.com)

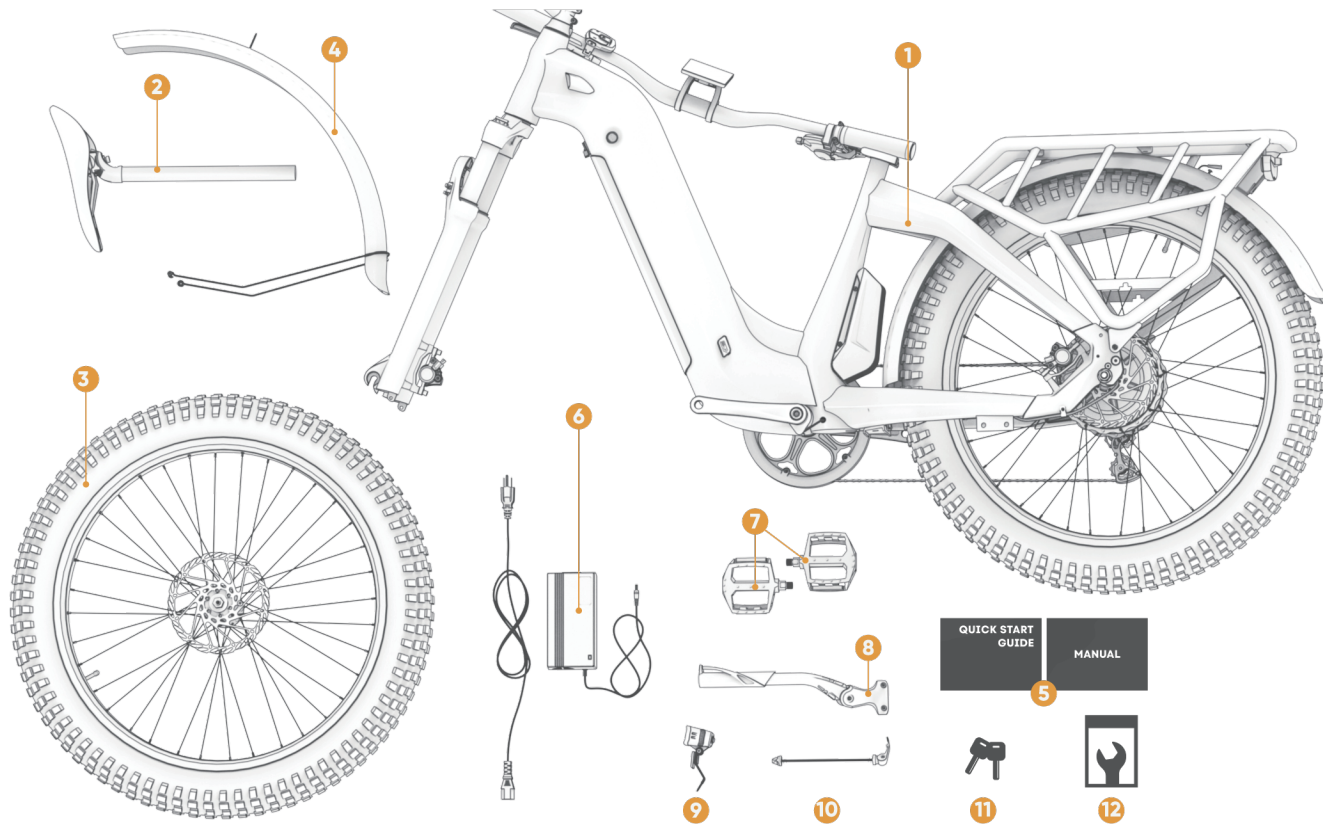

CHECK LIST

PACKAGE	#	PART	DESCRIPTION		QTY
Master Carton	1	Cyke Bike			1
	2	Seat Post			1
	3	Front Wheel			1
	4	Front Fender			1
Accessory Box	5	Manual	A	Quick Start Guide	1
			B	Owner's Manual	1
	6	Charger			1
	7	Pedals	A	Left Pedal	1
			B	Right Pedal	1
	8	Kickstand			1
	9	Headlight			1
	10	Quick Release			1
	11	Battery Keys			2
	12	Tools Kit	A	13-15mm Open Wrench	1
			B	8-10mm Open Wrench	1
C			M2.5 Hex	1	
D			M3 Hex	1	
E			M4 Hex	1	
F			M5 Hex	1	
		G	M6 Hex	1	
Not Provided		Phillips Screwdriver			1



NOTICE: The appearance of components slightly varies between different batches, therefore the pictures in this manual are for reference only but do not affect the description and interpretation of the product. Please refer to the actually received ones.

STEP 1. ATTACH THE KICKSTAND

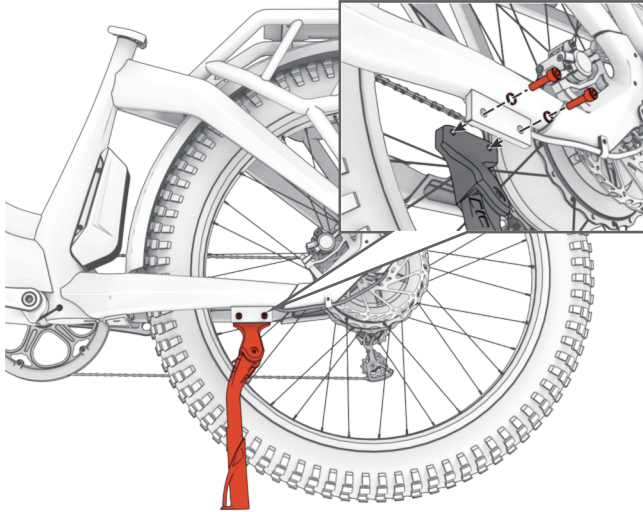

Open the shipping carton and carefully remove your bike from the bottom tray. Kickstand comes with 2 bolts. Remove the 2 bolts from the kick-stand with the M4 hex key. Put the kickstand under the bike and align the holes on it with the holes on the bike. Then thread the bolts into the holes and tighten them with the M4 hex key.

STEP 2. ATTACH THE FRONT WHEEL

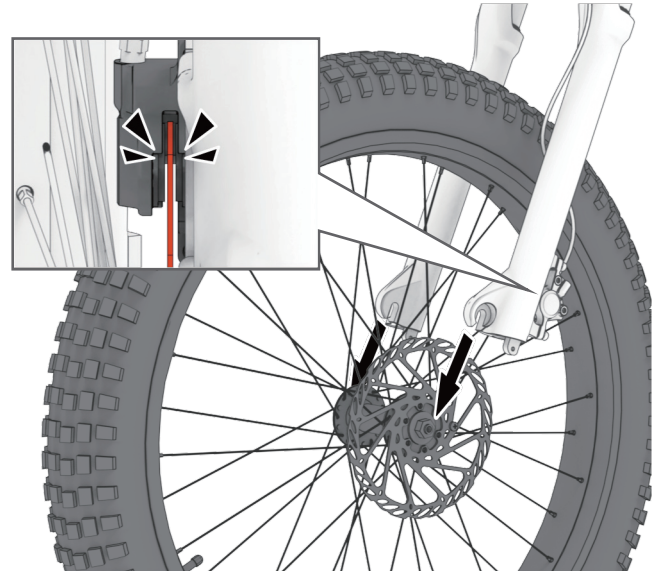

First, remove the brake protection plate, and slide the front wheel into the front fork, so that the disc brake is inserted into the center of the brake caliper, while the front hub axle is stuck into the front fork slot.



WARNING! Please ensure that there is a proper gap between the brake disc and the brake pad in case of disc collision, which may cause damage to the brake kit or even pose a major threat to personal safety.

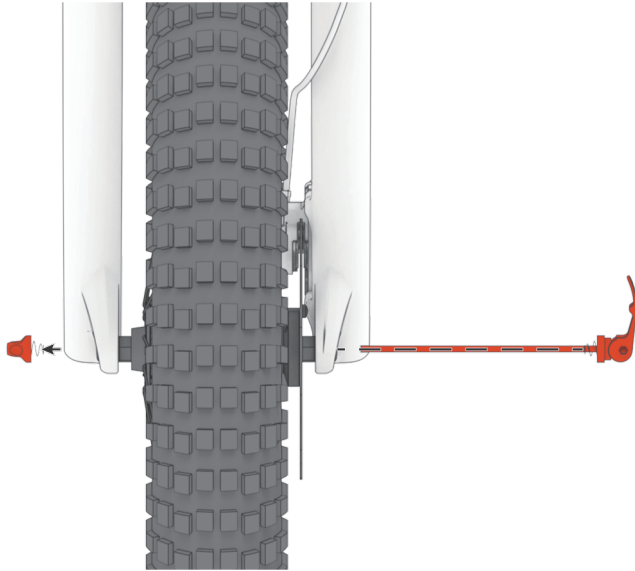

Take out the quick release and unscrew the adjustment nut and the spring on the same side. Slide the axle through the front wheel hub so the quick release lever is on the same side as the disc brake.

Thread the adjustment nut back onto the skewer, but do not tighten them too far. Leave enough place so you can put the axle into the dropout.

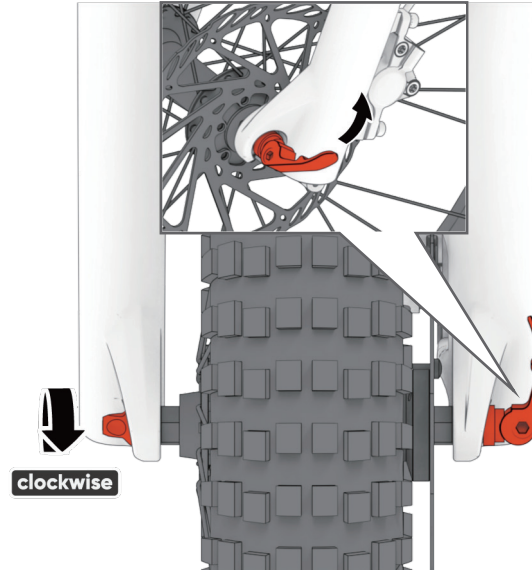

Move the quick-release lever into the open position. With one hand on the quick-release lever and the other on the adjustment nut, hand tighten the adjustment nut until you start to feel some resistance against the fork.

You should feel resistance when you close the quick-release lever that should leave a temporary impression on your fingers. Open and close the handle again to ensure the wheel is securely locked in place.

STEP 3. ATTACH THE HANDLEBAR

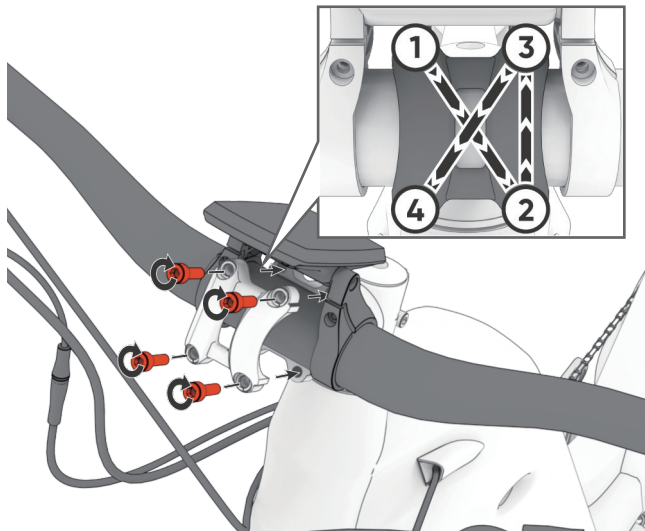

Remove the handlebar clamp from the stem by removing all screws with the M5 hex key. Insert the handlebar into the stem and reinstall the clamp. Make sure the handlebar is aligned with the front wheel before tightening and the stem is not set above the maximum height indicator.

Tighten all screws evenly in a crosswise pattern. Make sure handlebar is in the preferred position before the final tightening of screws.

STEP 4. FRONT FENDER AND HEADLIGHT

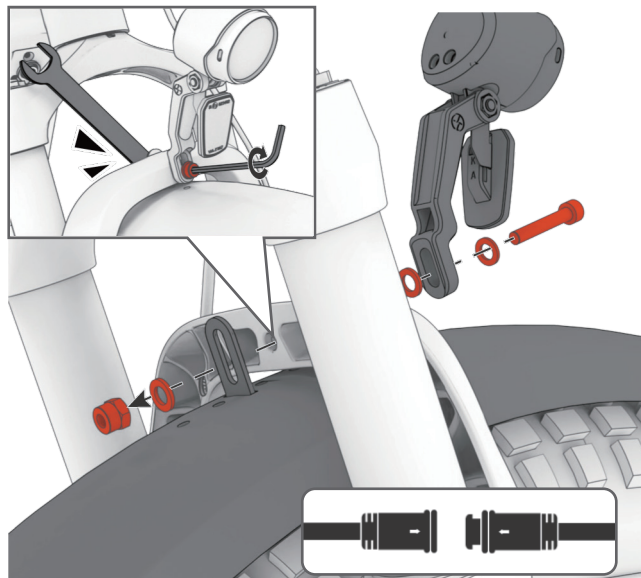

Unscrew the nut and gasket from the end of the long bolt and make sure the headlight bracket is on the outside of the frame and the fender bracket is on the inside. Align the holes on the two brackets to the hole on the fork crown. Pass the long screw through the holes. Tighten the screwed nut from the end of the long screw with the M5 hex key and 10mm open wrench.

Connect Headlight: Keep the arrows aligned and insert the connectors plug.



Unscrew the bolt first. Connect the fender struts with the fork by tightening the screws and flat washer clockwise with the M4 hex key.

Repeat these steps for the other side.

STEP 5. ATTACH THE PEDALS

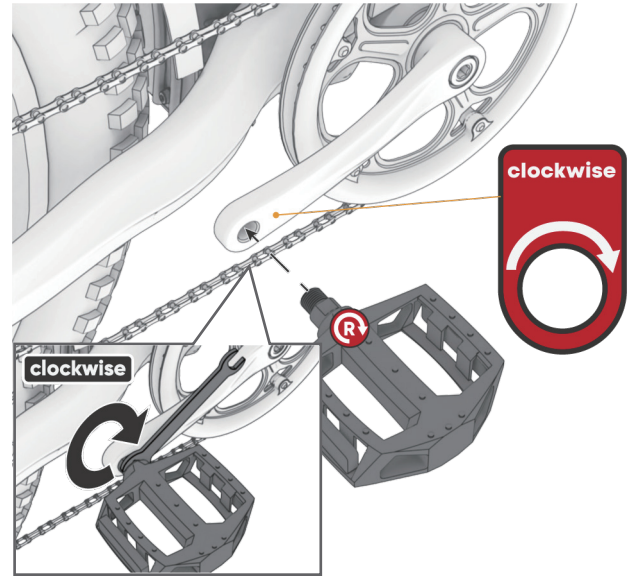

Insert the right pedal ("R" sticker) into the right crank's threaded hole and rotate the pedal (clockwise) until some tension is felt.

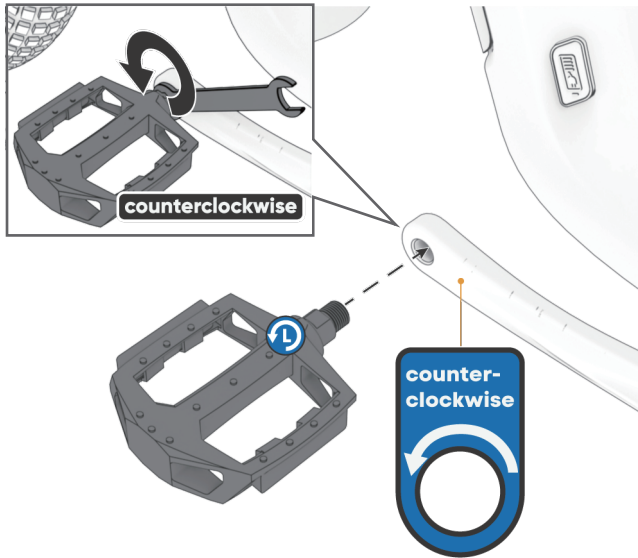

Repeat these steps for the left pedal ("L" sticker) in the left crank, but rotate and tighten the pedal counterclockwise.



CAUTION: Make sure to install the pedals correctly. The left and right pedals have opposite threads and can damage the cranks if installed on the wrong side.

STEP 6. ATTACH THE SEAT HEIGHT

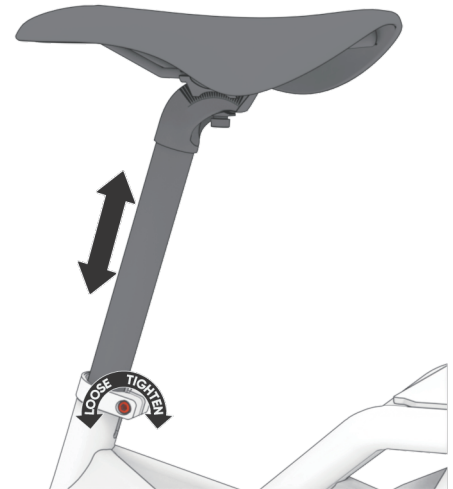

Loosen the adjustment bolt of the seat clamp, insert the seat tube, then lock the adjustment bolt after adjusting to the appropriate height.



NOTICE: Please refer to the Seatpost Height Adjustment section in the owner's manual for how to adjust the seat tube.

ACTIVATE THE BATTERY



If you use the battery for the first time or do not use it for 15 days, press and hold the battery wake-up button for more than 10 seconds to activate the battery until the indicator next to it flashes.



NOTICE: Please refer to the Battery and Charger Chapter in the Owner's Manual for more notes about the removal, installation and charging of the battery.

HMI CONTROL GUIDE

Turn on/off the display **(HOLD)**

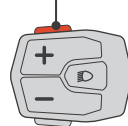

Turn on/off the lights

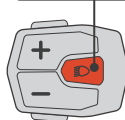

Increase the assist level

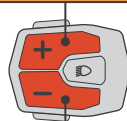

Decrease the assist level



1. Top it at PAS 0 state
2. Hold it to enter the walk assist mode

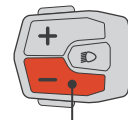

Switch the assist mode **(HOLD)**

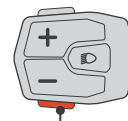

10s after start-up, press to enter Info Interface
Within 10s of start-up, hold to enter Option Interface
10s after start-up, hold to enter Clearance Interface



NOTICE: For more detailed Display Operation and Settings, please refer to the HMI Display Control Chapter in the Owner's Manual.

ENJOY YOUR RIDE!

Now you have basically finished the assembly of the CYKE bike. However, we strongly recommend that you read our Owner's Manual thoroughly before you start your first ride, especially for users who ride an e-bike for the first time. You need to learn how to use the electric power assist system, how to charge and maintain the battery, and gain more knowledge about riding and maintenance.

Before your first ride, please adjust the height and angle of your seat and handlebar to the appropriate position. If you can not judge whether your setting is appropriate, please consult the local e-bike shop or dealer, or directly contact us.

Before each ride, please check: whether bolts and nuts are loose; whether the power assist system works properly; whether the transmission components need to be maintained, and the braking force and wear of brakes. You'll need to consult the Owner's Manual for more detailed safety checks to make sure the e-bike is in good condition before each ride. If there are any above problems, please contact CYKE after-sales immediately.

CYKE

cykebikes.com

VERSION: V1.0

**READ THESE INSTRUCTIONS CAREFULLY
BEFORE FIRST USE AND KEEP THEM FOR
FUTURE REFERENCE.**

SUPPORT

 (888) 778-6789

 support@cykebikes.com