

# UNDER DESK TREADMILL

JK30F-9

*Thank you very much for purchasing our product. Please read this manual carefully before using it and keep the manual at the proper place.*



---

As shoppers, we're always trying to find the perfect balance between quality & value. At FYC, we believe we've achieved that. Our diverse catalog of everyday essentials is tailored especially to our customers & guaranteed to hit that sweet spot of high quality & low price.

— Always —

## CAUTION

To avoid injury please read this manual carefully before operating this machine

- NEVER attempt to mount the treadmill while the running belt is moving.
- NEVER step off the treadmill while the running belt is moving.
- NEVER operate the treadmill if it is damaged or is not working as it should be.
- DO NOT overexert yourself or work to exhaustion. If you feel any pain or abnormal symptoms, stop your workout immediately and consult your doctor.
- DO NOT operate the treadmill in or around water / sources of heat & avoid placing the treadmill on thick carpet.
- DO NOT use outdoors. This product is to be used inside ONLY.
- DO NOT place any objects on the running belt or the treadmill itself.
- NEVER connect a live power cable to the treadmill. Please turn off the power supply and the On/Off switch on the back of this machine before connecting the power cable to the machine. Once safely connected you can switch on the power supply followed by the on/off switch on the back of the machine. Connecting a live cable directly into the back of the machine can damage the electrical components.
- Storing the treadmill in a cold damp room i.e., garage (with non-consistent temperature) will increase the risk of damage to electrical components. We recommend that you store the machine in a dry room with constant temperature.

## SAFETY NOTICE

- This machine is not suitable for children under 14 years of age.
- Use the treadmill only for its intended use as described in this manual.
- Children, elderly users and pregnant women are advised NOT to use the treadmill.
- Assemble and operate the treadmill on a solid, level surface. Locate the treadmill a few feet from walls or furniture. Check the unit before each use and verify that all fasteners are secure. Always maintain the treadmill in good working condition.
- An error may occur due to unstable power. DO NOT share a power socket with other high-powered items such as computers or air conditioning units.
- It is suggested to wear suitable sports trainers and sensible gym clothing when using the treadmill.
- Take care when folding and unfolding the treadmill before and after use.
- DO NOT attempt to service the treadmill yourself except for the maintenance tasks which are described in this manual. The treadmill does not contain any user-serviceable parts so disassembling it yourself will not only void your warranty but could result in serious injury.

## ⚠ CAUTION DURING USE

Keep both the machine and power cord away from heated surfaces.

- Make sure you are wearing proper exercise clothing and shoes during a workout—no loose clothing. Tie back long hair. Keep all loose towels away from the running surface. The running belt will not stop immediately if an object becomes caught in the belt or rollers.
- If you begin to feel unwell during use, stop immediately and consult your doctor or personal trainer before continuing.
- Take care when adjusting the speed setting and increase or decrease steadily.
- The safety tether cord clip must be attached at waist level prior to starting a workout. The safety cord connects the security clip to the yellow button on the console. If you encounter any type of difficulty while using the treadmill, a strong tug on the safety key cord or a quick tap on the red ON/OFF button will stop the running belt.
- Please make sure the running belt is fastened before using.
- DO NOT adjust the belt while machine is turned on or being used.
- Please switch off all functions and disconnect from mains power supply after use.



## TOOLS REQUIRED



ALLEN WRENCH  
(PROVIDED)



SILICONE OIL  
(PROVIDED)



265 LBS  
CAPACITY



DO NOT  
NEED TO INSTALL



**This product is free of installation, home office can be used**

## PRODUCTS MAIN PARTS

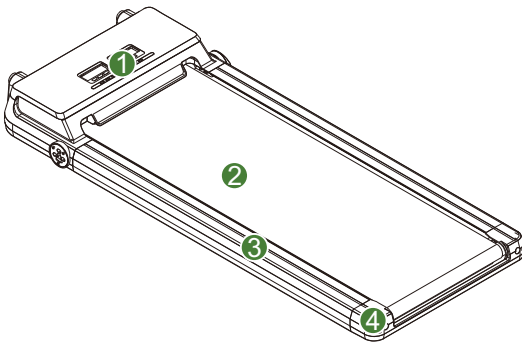

- 1、 Display
- 2、 Running Belt
- 3、 Side Rail
- 4、 End-Cap

## FOLDING UP AND SETTING DOWN

Product name	JK30F-9
Voltage	110V
Frequency	50-60Hz
Speed	0.5-4MPH

## BLUETOOTH SETUP

- Turn the treadmill on to make the speakers discoverable to your device under the name: **Bluetooth**
- On the device you want to pair with the speakers, open Bluetooth Setting (reference device manual to locate), find and select **Bluetooth**



# CONSOLE INSTRUCTOR

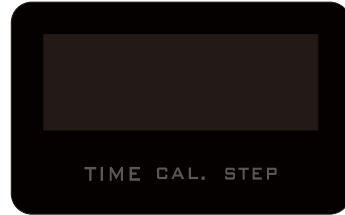

## (1). Display

•1.1 "TIME" window has two modes which shows the running time.

- ① Forward counting time is from 0:00 to 99:59 minutes.
- ② Countdown is count to 0 from the set time (setting range: 5:00-99:00 minutes). The machine will stop slowly when it counts to 0:00 and shows "end", then the machine will come to the standby mode after 5 seconds.

"STEP" window shows the steps.

It counts from 0 to 9999 steps. It will recount when the step numbers reach the top point.

**NOTE:** The window will be switched from TIME and STEP cyclically, you can press "M" button to switch between cyclic display mode and single display mode.

•1.2 "DISTANCE" window has two modes which shows the current movement distance.

- ① Forward mode counts from 0 to 9999, it will recount when it reaches the top point.
- ② Countdown mode will count from setting calorie data (setting ranges 20-990) to 0. The machine will stop slowly when it counts to 0:00 and shows "END", then the machine will come to the standby mode after 5 seconds.

**Note:** The window will be switched from DISTANCE and CALORIES cyclically, you can press "M" button to switch between cyclic display mode and single display mode.

•1.3 "SPEED" window shows the current running speed, the setting range is 0.5MPH-4.0MPH.

The speed will +/- 0.1MPH every time you click "+/-" button. P1 ~ P12 are displayed under the setting of automatic selection.

•1.4 After the treadmill is started, every window will be displayed cyclically at an interval of 5 seconds. You can press the "M" button to switch between cyclic display mode and single display mode.

# Functional Instruction

- 1. **Sports mode:** Press "⏻" key to start the machine and the SPEED window will count from "3 2 1". Please note that the default speed is 0.5 MPH and you can press "+" or "-" to adjust speed.
- 2. **Countdown mode:** when in standby, press "M" key to choose countdown for Time, Distance and Calories. Press "+" or "-" to set relevant data. After setting, press "⏻" to start the treadmill and it will count down from the set data, the machine will stop by itself when it counts to 0.
- 3. **Preset program(P01-P12):** choose one program first and then press "+" or "-" to set the running time (ranges 5:00~99:00, and the default time is 30:00), press "⏻" to start the machine, it will run according to the preset speed and speed will change according to the time "(Time/20)".

Time Programs		Set time / 20 = running time of each period																			
		1	2	3	4	5	6	7	8	9	10	11	12	13	14	15	16	17	18	19	20
P01	SPEED	1.8	1.8	2	2.6	3	2	2.6	3	3	2	2.6	3	2.6	2.6	2.6	1.8	2	3	2	1.8
P02	SPEED	1.8	2	2.6	3	3.2	2.6	3.2	3.2	3.2	2.6	3	3.2	2.6	2.6	2.6	1.8	2.6	3	2	1.8
P03	SPEED	1.8	2.6	2.6	3.2	3.2	2.6	3.6	3.6	3.6	2.6	3.6	3.6	2.6	2.6	2.6	1.8	3	2	2	1.8
P04	SPEED	1.8	3	3	3.2	3.2	3.2	3.2	2.6	2.6	1.8	1.8	2.6	3.6	3.2	3.2	3.2	3.2	3.2	2.6	1.8
P05	SPEED	2	2	3	3.6	3.2	3.2	4	3	3	4	4	3	3.2	3	4	3	3.6	30	2.6	3
P06	SPEED	2	4	4	3.6	4	3.2	4	3.2	2.6	1.8	3	2.6	3.6	3.2	3.2	3.2	4	3.2	2.6	2
P07	SPEED	2	2.6	3.2	3.2	4	3.2	4	3.6	3	3.2	3.2	3.2	3.2	3.6	4	3.6	3.2	3.2	3	2
P08	SPEED	2	3	3.6	3.6	4	4	3.6	4	2.6	3.6	3.6	2.6	3.6	3.6	4	3.6	4	3.6	3	2
P09	SPEED	2.6	3.6	2	3.6	3.6	3.6	4	4	3	4	3.2	3.6	3.2	3.6	4	4	3.6	3.6	3	2
P10	SPEED	2.6	3	2	4	4	4	4	4	2.6	4	3	2.6	3.6	4	3.6	3.6	4	3.6	3.2	2.6
P11	SPEED	2.6	4	3.2	4	3.6	3.2	3.2	4	3	4	4	3.2	3.2	3.2	3.2	3.2	3.6	4	4	1.8
P12	SPEED	2.6	2.6	3.6	4	1.8	4	4	4	4	4	4	4	3.6	4	4	1.8	4	4	4	1.8



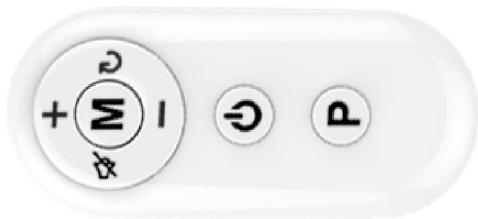

# REMOTE CONTROL INSTRUCTION



## 1. Function of the Remote Control

### 2.1

- (1) In standby or countdown mode: Pressing " "button to start the machine. Please note that the default speed is 0.5MPH.
- (2) Choose the preset program: Pressing " "to start the machine and the speed will change according to the preset speed.
- (3) In running state: Pressing " ", then the treadmill will stop slowly and back to standby state.

### 2.2 "+"/"-"

- "+"/"- "button is to adjust speed. Keep pressing "+"/ "-" over 0.5 seconds, the speed will keep increasing or decreasing. Please note the speed will change by 0.1MPH.

### 2.3 "M"

- (1) in standby mode: it can switch from different mode, including Time, Distance and Calories. Choose one of modes, and then press + or - button to set target. After setting the target, press start button to start treadmill.
- (2) in running mode: press "M" button will switch display mode between cyclic display mode and single display mode.

### 2.4 "P"

- "P": There are P01-P12, totally 12 preselected programs you can choose when in standby mode.

### 2.5

- Press the " " button to mute the treadmill (no sound "Bi"); press it again to resume the beep sound.

### 2.6



- After using, press " " button, the treadmill will stop slowly and it will retain its data until power off. It will resume the previous speed when it starts again.

## 2.7

- Press the " " button, the data will be reset to its default data. It only works when the treadmill is in standby mode.

※**REMARK:** Any valid pressing, the treadmill will make a sound "Bi"

## ABOUT THE REMOTE CONTROL

- 3.1 Pull out the insulating sheet, you can use the remote control directly.
- 3.2 The remote control can directly control the treadmill.
- 3.3 If you have purchased multiple treadmills, in order to prevent the treadmills from interfering with each other, please perform the following operations to match:
  - 3.3.1 Turn on the one of treadmills.
  - 3.3.2 Simultaneously press the  and  buttons together on the remote control for 5 seconds. The display screen will flash, and the treadmill will match the remote control.
  - 3.3.3 Please note: After matching the remote control, if remote control is replaced, please rematch it with the above step.

## HOW TO MATCH A NEW REMOTE CONTROL

- 4.1 Power off the treadmill.
- 4.2 Press the "speed -" in the treadmill and "M" button in the remote control at the same time, then keep pressing for 6 seconds.
- 4.3 Start the treadmill within 5 seconds, the remote control will match the machine.



## USAGE OF SILICONE OIL

1. Before you start the treadmill, please lubricate the running belt first. Pull up the running belt slightly, apply silicone oil to the backside of the belt and the top surface of the running deck.
2. Start the treadmill and keep it running for 3 minutes so that the oil spread and even out. It is necessary to maintain your treadmill **every 30 working hours** of the treadmill for optimal performance, which also helps extend the service life of parts.

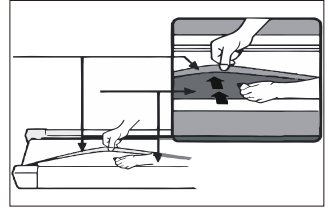

For your convenience, you can scan this QR code to see the video for lubricating the running belt on YouTube, or input this link to watch.



<https://youtu.be/MksJloi8Obo>

## RUNNING BELT ADJUSTMENT

After installation video tutorial

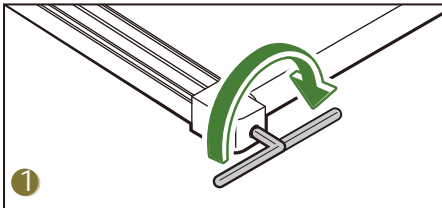

### RUNNING BELT SKEWS TO THE LEFT

1. Start the machine by speed at 1.2-1.8mph without loading, use Allen wrench to turn the screw 1/4 circle clockwise (see fig1).
2. Then make the machine running without loading 1-2 minutes. Please adjust the belt like this to the middle position.

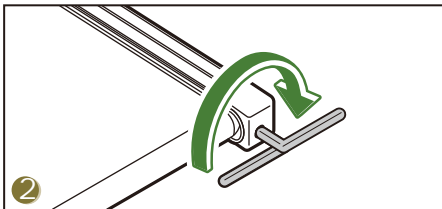

### RUNNING BELT SKEWS TO THE RIGHT

1. Start the machine by speed at 1.2-1.8mph without loading, use Allen wrench to turn the screw 1/4 circle clockwise (see fig2).
2. Then make the machine running without loading 1-2 minutes. Please adjust the belt like this to the middle position.

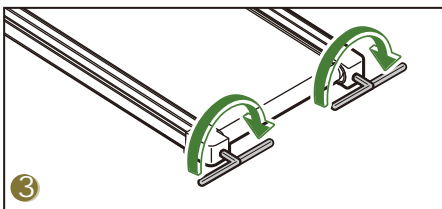

### RUNNING BELT IS IN THE LOGJAM

1. If the running belt is in dead condition, use Allen wrench to make the screw 1/2 circle both left and right till this logjam solved.



### ***RUNNING BELT DEVIATE TO LEFT***

For your convenience, you can scan this QR code to see the video on YouTube, or input this link to watch.



<https://youtu.be/uoXqZXk1Bx8>

1

### ***RUNNING BELT DEVIATE TO RIGHT***

For your convenience, you can scan this QR code to see the video on YouTube, or input this link to watch.

<https://youtu.be/LGKKCk-yivM>



2



(STEP1)



(STEP2)

### ***RUNNING BELT LOGJAM***

For your convenience, you can scan this QR code to see the video on YouTube, or input this link to watch.



STEP1: <https://youtu.be/Xqri9ug5J7c>



STEP2: <https://youtu.be/nyZ75WFTZZw>

3

## **DAILY MAINTENANCE**



1. Please disconnect power before checking the machine or cleaning.
2. Clear the belt and dial plate after use, at least once a week.
3. Check and tighten screws and spines at fixing point.
4. Do not hang clothes or other objects on the machine.

# EXERCISE GUIDE

**PLEASE NOTE:** Before beginning any exercise program, consult your physician.

This is important especially if you are over the age of **45** or individuals **with pre-existing health** problem.

The pulse sensors are not medical devices. Various factors, including the user's movement, may affect the accuracy of heart rate readings. The pulse sensors are intended only as an exercise aid in determining heart rate trends in general.

Exercising is great way to control your weight, improving your fitness and reduce the effect of aging and stress. The key to success is to make exercise a regular and **enjoyable part of your everyday life**.

The condition of your heart and lungs and how efficient they are in delivering oxygen via your blood to your muscles is an important factor to your fitness. Your muscles use this oxygen to provide enough energy for daily activity. This is called aerobic activity. When you are fit, your heart will not have to work so hard. It will pump a lot fewer times per minute, reducing the wear and tear of your heart. **So, as you can see, the fitter you are, the healthier and greater you will feel.** 😊

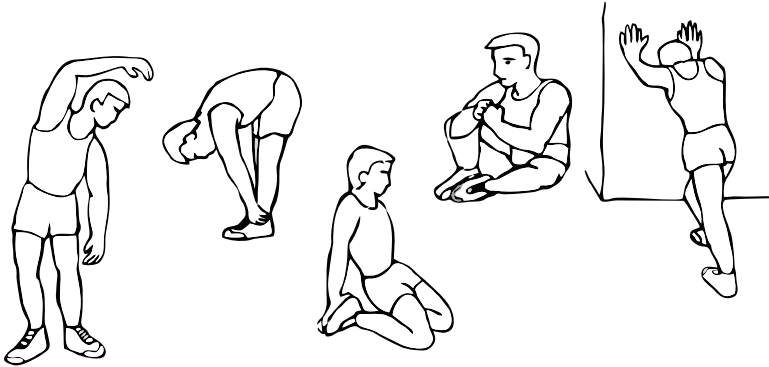

## Warm-up



- Start each workout with **5 to 10 minutes** of stretching and some light exercises. A proper warm-up Increase your body temperature, heart rate and circulation in preparation for exercise. Easy into your exercise.

## Training Zone Exercise



- After warming up, increase the intensity to your desired exercise program. Be sure to maintain your Intensity for maximum performance. Breathe regularly and deeply as you exercise-never hold you breathe.

## Cool Down



- Finish each workout with a light jog or walk for at least 1 minute. Then complete **5 to 10 minutes** of stretching to cool down. This will increase the flexibility of your muscles and will help prevent post- exercise problems.

## HEART RATE

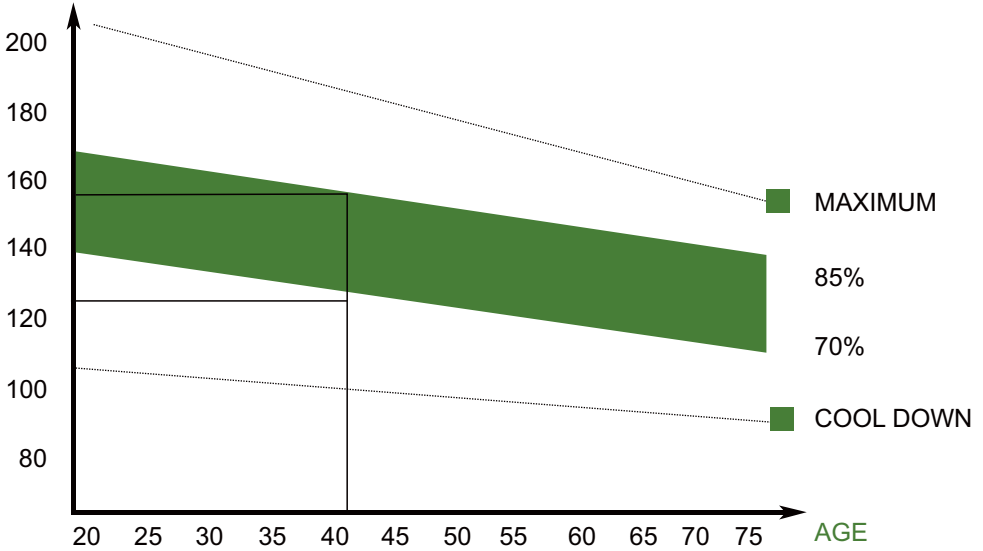

## THIS IS HOW YOUR PULSE SHOULD BEHAVE DURING GENERAL FITNESS

### EXERCISE. REMEMBER TO WARM UP AND COOL DOWN FOR A FEW MINUTES

The most important factor here is the amount of effort you put in. The harder and longer you work the more calories you will burn. Effectively this is the same as if you were training to improve your fitness, the difference is the goal.

MADE IN CHINA

# FCC STATEMENT

## FCC STATEMENT (Bluetooth function)

1. This device complies with Part 15 of the FCC Rules. Operation is subject to the following two conditions: (1) This device may not cause harmful interference, and (2) This device must accept any interference received, including interference that may cause undesired operation.
2. Changes or modifications not expressly approved by the party responsible for compliance could void the user's authority to operate the equipment.

This equipment has been tested and found to comply with the limits for a Class B digital device, pursuant to part 15 of the FCC Rules. These limits are designed to provide reasonable protection against harmful interference in a residential installation. This equipment generates, uses and can radiate radio frequency energy and, if not installed and used in accordance with the instructions, may cause harmful interference to radio communications. However, there is no guarantee that interference will not occur in a particular installation. If this equipment does cause harmful interference to radio or television reception, which can be determined by turning the equipment off and on, the user is encouraged to try to correct the interference by one or more of the following measures:

- “ Reorient or relocate the receiving antenna.
- “ Increase the separation between the equipment and receiver.
- “ Connect the equipment into an outlet on a circuit different from that to which the receiver is connected.
- “ Consult the dealer or an experienced radio/ TV technician for help.

# FCC STATEMENT

## FCC STATEMENT (Remote control function)

1. This device complies with Part 15 of the FCC Rules. Operation is subject to the following two conditions: (1) This device may not cause harmful interference, and (2) This device must accept any interference received, including interference that may cause undesired operation.
2. Changes or modifications not expressly approved by the party responsible for compliance could void the user's authority to operate the equipment.

This equipment has been tested and found to comply with the limits for a Class B digital device, pursuant to part 15 of the FCC Rules. These limits are designed to provide reasonable protection against harmful interference in a residential installation. This equipment generates, uses and can radiate radio frequency energy and, if not installed and used in accordance with the instructions, may cause harmful interference to radio communications. However, there is no guarantee that interference will not occur in a particular installation. If this equipment does cause harmful interference to radio or television reception, which can be determined by turning the equipment off and on, the user is encouraged to try to correct the interference by one or more of the following measures:

- “ Reorient or relocate the receiving antenna.
- “ Increase the separation between the equipment and receiver.
- “ Connect the equipment into an outlet on a circuit different from that to which the receiver is connected.
- “ Consult the dealer or an experienced radio/ TV technician for help.

## FCC Radiation Exposure Statement:

This equipment complies with FCC radiation exposure requirement.  
The device can be used in portable exposure condition without RF restriction.

MADE IN CHINA



# TROUBLE SHOOTING

ERROR CODE	PROBLEM	SOLUTION
Err	Connecting wire cable loose/damage from the control board	Remove the motor cover and check all the connecting wire cable
.....	Connecting wire cable loose/damage from the control board	Remove the motor cover and check all the connecting wire cable
E5	Overload Protection	Please lubricate the running belt and check if the motor works well
		Motor or Control Board damaged, please replace it
E6	MOS Protection	Check whether the motor wire is damaged or broken
		Replace the control board
E7	Connecting wire cable loose/damage from the control board	Remove the motor cover and check all the connecting wire cable
E8	Electric motor damage/broken	Replace the motor
	Connecting wire cable loose/damage from the control board	Remove the motor cover and check all the connecting wire cable





*Dear Sir/Madam:*

*Thank you for choosing us. Hope you will enjoy our items. Our goal is provide better quality items and customer service.*

*Your suggestions and shares about our items&service are really important to both of us and other buyers. We sincerely invite you to go back to our store and leave your thoughts, share and experience. It would be quite encouraging if you could do like this:*



One year warranty



Product Inquiry



Orders FAQ



Product Assembly



Returns & Refunds

## WARRANTY

Your purchase includes a hassle-free Money Back Guarantee and a free replacement exchange for one year. Within the warranty period, we provide the FREE replacement parts. If caused by incorrect assembly, incorrect use or change of parts failures, our company takes no responsibility. You should show our products series no. and relative pictures or videos or concern information before getting the warranty.

This treadmill is only for home use, if the problems occurred by commercial used, our company takes no responsibility.

### ★★★★★Great products so far

February 24, 2018

Great product so far. Fast delivery, easy setup, and working without any issues.

With your inspiring rating, FYC will be more consistent to offer you

EASY SHOPPING EXPERIENCE, GOOD PRODUCTS and EFFICIENT SERVICE!

If you have any issues with your orders, logistics, items, etc, please contact us bythe following way.



Email: [hellofyc@outlook.com](mailto:hellofyc@outlook.com)



Whatsapp: +86 158 2450 5304



Telephone: 011 86 574 83096029