

TRI-RING COOKTOP - GLS30501

FOTILE

30" Built-In Gas Cooktop

FOTILE offers an impressive 30" gas cooktop with 5 sealed burners, including a center mounted Tri-Ring burner with 21,000 BTUs and wok support. Overall heat output for the FOTILE Tri-Ring gas cooktop is 56,000 BTUs. FOTILE Tri-Ring gas Cooktops - We are professional grade for your kitchen!



+ Signature Features



21,000 BTU Tri-Ring Output Center burner
Tri-Ring High Output Center burner can be used for power boiling, searing, pan frying and stir frying with the included wok attachment. The Tri-Ring Burner provides directional heat to the pan by positioning the flame based on the amount of burner rings you turn on.



Two left burners deliver **13,000 BTUs** each offering high heat along with optional griddle control.



Flame Failure Device will automatically cut off the gas supply within 20 seconds in case the flame goes out.



Dedicated Simmer Burner capable of going to 3,000 BTUs. This low power burner is ideal for simmering or heating delicate sauces with accurate consistent low temperature so they will not burn.

+ Other Features

Stainless Steel Finish

Easy to Clean

Sealed Burners

Edge to Edge Cast Iron Grates

High Heat Output:

- Center: 21K BTU

- Left Front/Rear: 13K BTU x2

- Right Front: 6K BTU

- Right Rear: 3K BTU

TRI-RING COOKTOP - GLS30501

FOTILE

30" Built-In Gas Cooktop

Installation Information:

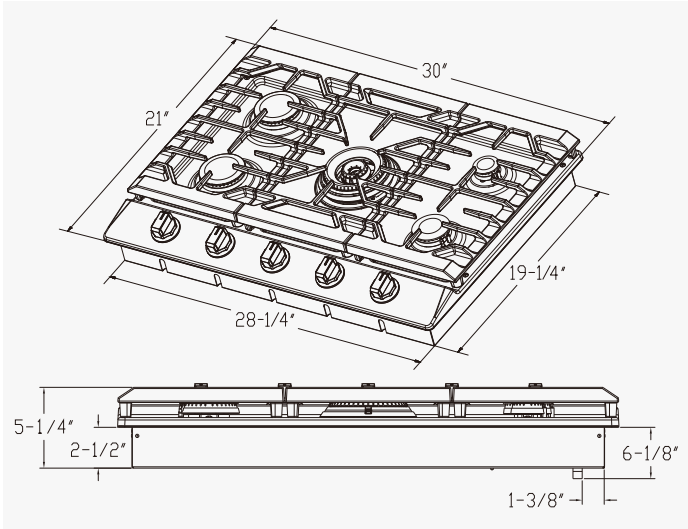

- Product Dimensions (W x D x H) (inch)
30 x 21 x 5 1/4
- Cut-out Dimensions (W x D) (inch)
(Min 28 1/2 - Max 29) x (Min 19 5/8 - Max 20 1/8)
- Product Weight (lbs)
50.5lbs
- Power Source
120V/60HZ
- Shipping Dimensions (W x D x H) (inch)
34 5/16 x 25 1/4 x 10 1/16
- Shipping Weight (lbs)
60.4lbs
- Warranty
One (1) Year All Parts and Labor, Four (4) Years All Parts

Important Installation Measurements

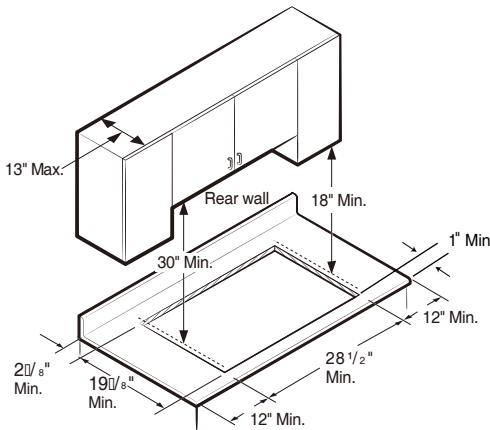

- 30" minimum clearance between top of cooktop platform and bottom of uncovered wood or metal cabinet.
- 18" minimum clearance from upper cabinet to countertop within minimum horizontal clearances to cooktop.
- 12" Minimum distance to combustible side wall above countertop (both sides).
- Allow 7/16" minimum vertical clearance from the cooktop bottom to any combustible surfaces, including the upper edge of a drawer installed below the cooktop.

Gas Connection

FOTILE gas cooktops are manufactured and shipped to be used with natural gas. If you want to use LPG, please convert the cooktop to LPG following the instructions in the Installation Manual.

