

FOTILE

A BREATH OF FRESH ENGINEERING™

Most known for its high-performance range hoods, FOTILE has been dedicated to improving family's kitchens for more than 20 years.

As the choice of kitchen appliances for over 17 million families worldwide, FOTILE has achieved a record-high revenue of \$1.9 Billion worldwide and a high-end kitchen appliance market share in China of over 43%.

FOTILE combines advanced technologies and aesthetic design to create happiness and wellness for families around the world.

With over 16,000 employees, and the largest State of the Art R&D Center out of any appliance company, FOTILE has earned nearly 3,500 patents with nearly 500 of them being for invention.

FOTILE has a complete line of Kitchen Appliances including Range Hoods, Steam Ovens, Electric Ovens, Gas Cooktops, Water Purifiers, and a unique 3-IN-1 In-Sink Dishwasher.

Welcome to FOTILE.

We are a Breath of Fresh Engineering.

FOTILE AMERICA LLC

Address:6 Campus Dr, Suite 210, Parsippany, NJ 07054

Website:www.fotileglobal.com

Tel:+18883150366

Media Contact Email:marketing@fotile.com

Service Email:serviceusa@fotile.com

Wechat:fotileus



fotile_america



Fotile America

FOTILE

Tri-Ring Cooktop - GLS30501

**A Professional Tri-Ring Cooktop
That Meets All Your Cooking Needs**

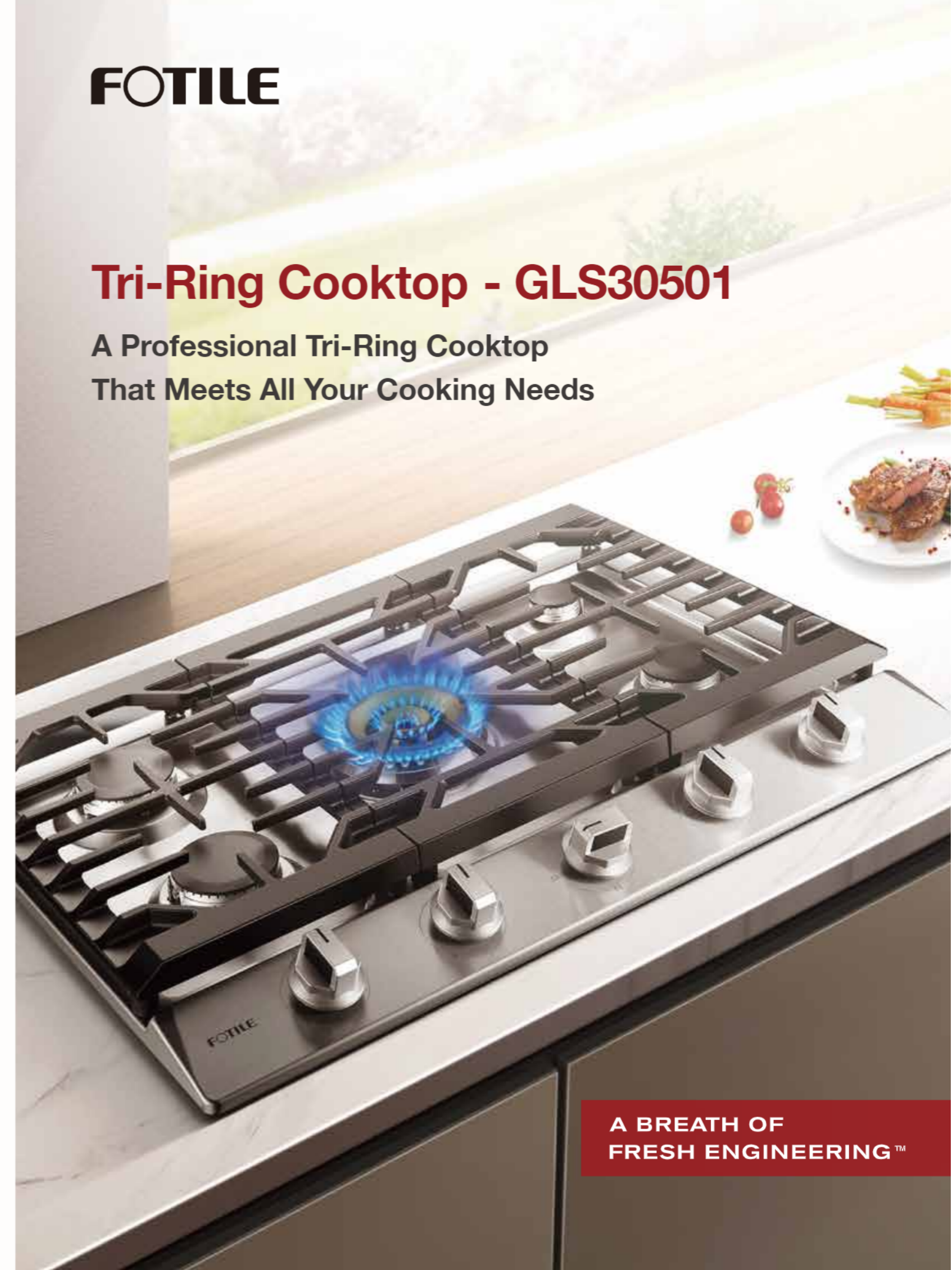

**A BREATH OF
FRESH ENGINEERING™**



An excellent and unforgettable cooking experience is undoubtedly related to the accuracy and control of fire and heat. With easy fast ignition, precise and swift flame control, and versatile functions, Tri-Ring gas cooktop, GLS30501 makes cooking enjoyable and convenient. Whether you want to cook for yourself or cook for friends and family at a dinner party, Tri-Ring Cooktop is the cooktop for you.



The main burner of GLS30501 features a diverse control range of heat 2,500BTU to 21,000BTU. It can easily be controlled to offer the precise heat amount for diverse types of cooking, whether it be power boiling or stir-frying with the included wok ring attachment.



Professional Tri-Ring High Output Center Burner

Compared with the standard burners, the professional tri-ring burner not only delivers a higher amount of heat, but also efficiently heats up the bottom of pots and pans more evenly. Whether stewing or frying, at high or low fire, the tri-ring burner can cook your food with great precision, and help avoid food not being evenly cooked through. You can adjust the three flame rings synchronously by rotating the knob counter-clockwise while increasing or decreasing the number of flame rings by turning the knob clockwise. Flexible heat control helps you deliver exceptional cooking results.

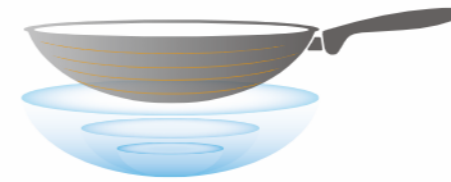

• FOTILE Tri-Ring Burner

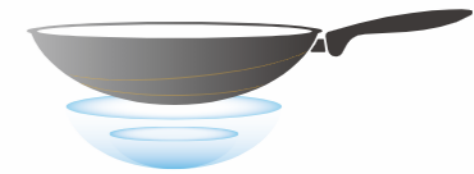

• Normal Double-Ring Burner

Copper Burners

Both burners and burner covers are made of pure copper, which has better thermal conductivity than aluminum-alloyed cast iron. Burners made of pure copper are not only outstanding in appearance, but are also able to withstand high temperatures, making them much more durable.



Copper Burner Cap

Copper Burner Head

One Cooktop Meets All Your Cooking Needs

Most of the burners offering as much as 20,000 BTU are typically designed for commercial use, and are rarely found in household cooktops.

Tri-Ring gas cooktop, GLS30501 makes it possible for you to show off your masterful cooking skills using household cooktops. The five well-designed burners offer different temperature ranges for different dishes and cuisines. Whether you want to cook fish, steak, paella, or tacos, the Tri-Ring Cooktop can always satisfy all your cooking needs.

21000BTU High Heat + Wok Ring

Whether you want to stir fry or barbecue, this cooktop can help you deliver outstanding results

The main center burner of the GLS30501 offers 21,000BTUs of high heat, which allows you to quickly power boil water, or sear both sides of fish or a steak. Want to do some stir fry? Just use the included Wok Ring attachment and you can make your favorite stir fry dish!



Dedicated Simmer Burner

If you want to melt butter, make jam, or carefully heat up chocolate, you can use the dedicated simmer burner with a low steady firepower of 3,000 BTUs.



Two Burners with Medium to High Heat Output along with Griddle Control

When cooking dishes such as whole cod or filet steak, a long grill pan can be useful. The two left burners of GLS30501 are designed with identical specifications. They deliver 13,000 BTUs each, offering medium to high heat along with control of the optional griddle pan.



A Cooktop that Gives You the Ultimate Peace of Mind



Flame Failure Detection Device

Are you frequently worried about gas leakage in case the burner flames go out accidentally? No worries! The Flame Failure Device will automatically cut off the gas supply if that ever happens.



Four-Sided Turn-Over Design

Sharp edges and burrs are removed to protect your hands from getting cut and injured.



Use of insulation materials to avoid the risk of accidental burns and electrical shock

The cooktop knobs are made of a special heat resistant material. No matter how long your cooktop has been on, you will never burn your hands using the cooktop control knobs.



Well Thought Out in Every Detail



Easy To Clean

GLS30501 is easy to clean. It features sealed burners which prevent spills and drips from entering the burner box. The inner edges of the panel have been rounded so that food residue can be easily removed. Both knobs and burners are removeable.



Fast Ignition

GLS30501 adopts a fast ignition system. Just press, turn and release the knob. This causes the burner to be ignited immediately. Each burner is equipped with one igniter. The well-designed ignition systems offer a better ignition success rate, which means longer service life of igniters.



Continuous Heavy Duty Cast Iron Grates

The edge-to-edge grates are easy to install and convenient to use. Even heavy pans and pots can be easily moved between different burners during cooking.

Premium Stainless Steel Design



Sophisticated craftsmanship
The cooktop can seamlessly fit into any kitchen countertop.



Childproof lock
Prevents children from turning on the cooktop.



Compatible with many types of pots and pans
Included wok ring and optional griddle.

Model

GLS30501

Appearance



Burner No.	5
Product Dimensions (WxDxH) (inch)	30 x 21 x 5 1/4
Cut-Out Dimensions (WxD) (inch)	(Min 28 1/2-Max 29) x (Min 19 5/8-Max 20 1/8)
Panel Material	Stainless Steel
Gas supply	Natural gas, LPG (need convert)
Power Source	120V/60Hz
Heating Load (Natural Gas)	Center: 21,000BTU
	LF/LR: 13,000BTUx2
	RF: 6,000BTU
	RR: 3,000BTU
Total: 56,000BTU	
Grate	Continuous Cast Iron Grates, Wok Ring, Optional Griddle
Fast Ignition	✓
Flame Failure Device	✓
Certification	ETL

Installation Information:

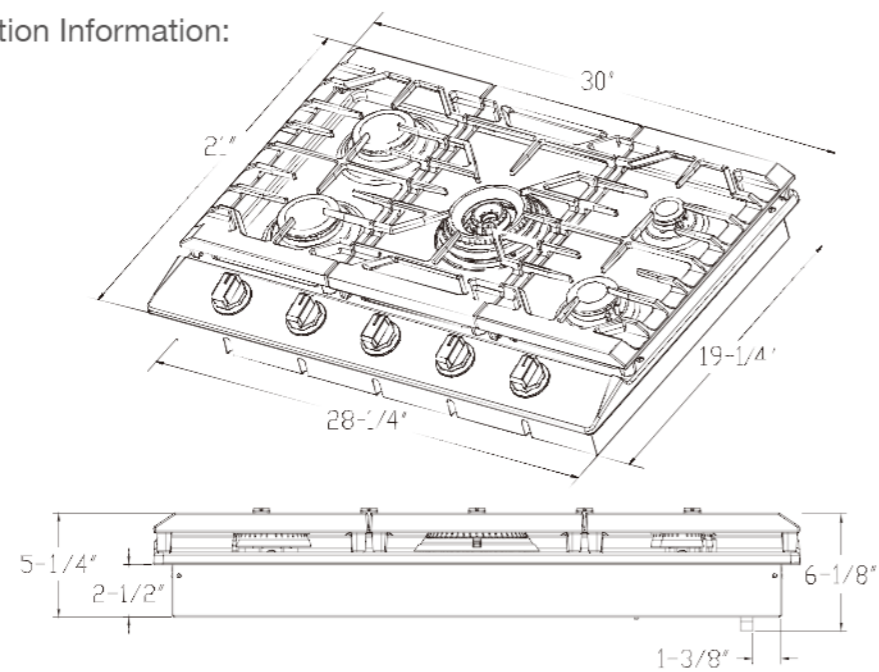

Installing The Cooktop:

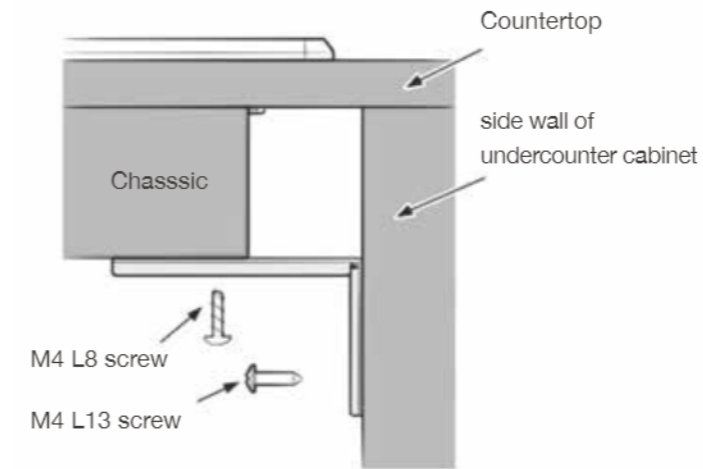
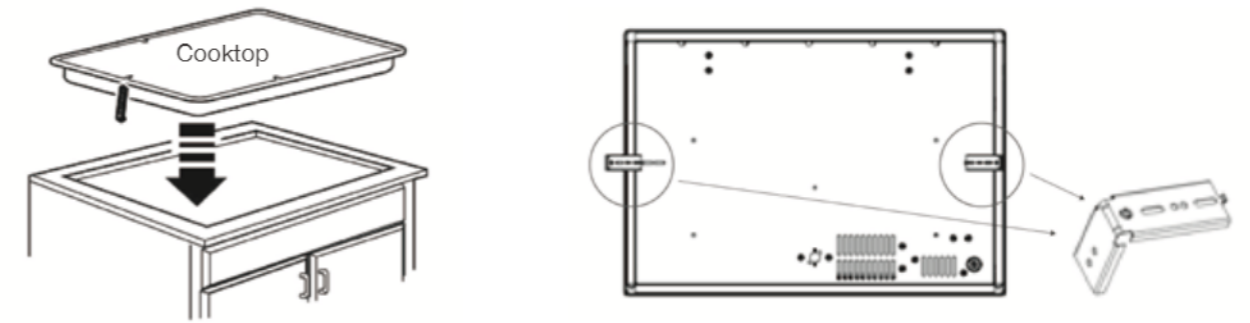

Installation Method 1

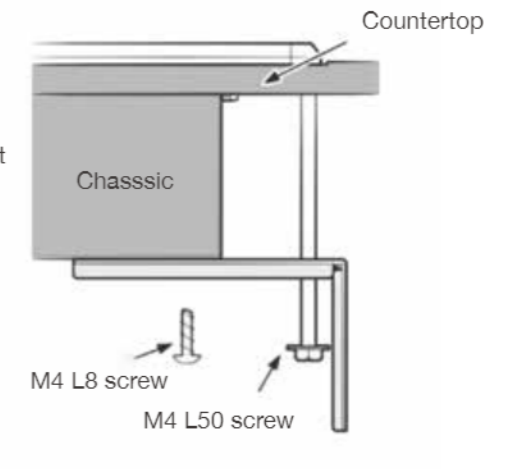

Installation Method 2

Choose installation method 1 or method 2 shown above to secure the cooktop to the countertop using the two provided hold-down brackets as shown.

