

FOTILE

Installation Manual

Please keep it in a safe place
for future reference

Please read this operation
manual carefully before
using the product

In-Sink Dishwasher

SD2F-P1X
SD2F-P1XL

CONTENTS

Dear Client,

Thank you for choosing the FOTILE sink dishwasher products manufactured by FOTILE. Please read the installation instructions carefully before installation.

Please call the FOTILE Service hotline for any needs at 1-888-315-0366.

CONTENTS ----- 1

Safety Instructions ----- 2

Installation Requirements ----- 3

 Installation List ----- 5

 Product Packing List ----- 5

 Auxiliary Materials for Installation ----- 6

 Installation Tools ----- 7

Installation ----- 7

 Product Dimensions ----- 7

 Installation Steps ----- 8

I. Safety Instructions

To avoid injury and property damage to users and other persons, please read and observe all safety instructions and warnings.

1. The personnel installing this product must have basic mechanical, electrical and plumbing skills. This product must be installed by certified professional plumbers.
2. It is the responsibility of the installer for correct installation, any product fault caused by improper installation will not be covered by the FOTILE warranty.
3. Disconnect the power before installing the product to prevent electric shock.
4. Do not wet the power cable, power plug, connectors or other electric parts, or it may cause electric shock or other accidental damages.
5. Do not modify, stretch, knot the power cable or place heavy objects on it. Doing so may cause damage to the power cable and result in electric shock, fire, etc.
6. Do not touch the power cable or electrical parts with wet hands, or it may cause electric shock.
7. The Sink Dishwasher must be connected to a grounded electrical outlet. If you don't have a grounded electrical outlet, please have a certified electrician install one. Failure to do so can result in electrical shock and injury.
8. If the power cable is damaged, it must be replaced by Fotile Service Technicians to avoid danger.
9. During installation, please pay attention to the edges and corners of the sink to avoid scratches.
10. Only cold water can be supplied to the water inlet of the Fotile sink dishwasher. Supplying hot water will affect the produce cleaning function for fruits and vegetables. The FOTILE Sink Dishwasher uses its' own heating element to heat water for dishwashing.
11. Do not allow children to play with the plastic film or other packaging components which may cause asphyxiation and possible death.
12. The countertop which the product is installed into must have sufficient strength to support 220 lbs (100Kg). Please follow all mounting directions to be firmly installed into the countertop correctly.
13. The countertop which this product is installed into, must be made from temperature and humidity resistant materials.
14. During product installation, the functional sink must maintain a distance of 11 13/16 "(300mm) or more from the gas meter and the gas pipeline. The junction box must be a distance of 5 15/16" (150mm) or more from the gas meter and gas pipeline.
15. Please adhere to all local laws and regulations for the connection of the drain hose.
16. Please save this Installation Manual for future reference.

II. Installation Requirements

To avoid injury and property damage to users and other persons, please read and observe all safety instructions and warnings.

1. Objects obstructing the functional sink and drain line such as a gas line or gas meter should not be installed in the cupboard;

Hose and equipment		Net Distance from Gas Hose	
		Parallel Lying	Cross Lying
Electrical equipment	Exposed insulated wire or cable	9 7/8"(250mm)	3 15/16"(100mm)
	Exposed wire with voltage less than 1,000V	39 3/8"(1,000mm)	39 3/8"(1,000mm)
	Switchboard or distribution box, electricity meter	11 13/16"(300mm)	Not allowed
	Electrical socket, power switch	5 15/16"(150mm)	Not allowed

2. The water supply and power socket should be arranged in the cupboard (or the adjacent cupboard).
3. The 240V/60Hz power supply shall be provided. A wire with a diameter of more than 16AWG (1.5 mm²) should be used and reliably grounded.
4. The pressure of the installation waterway should meet the requirements of 20.3 psi-145.04 psi.
5. Height requirements for drain hose: The height from the top of the installed countertop to the drain hose should be greater than or equal to 21 11/16 "(550mm).

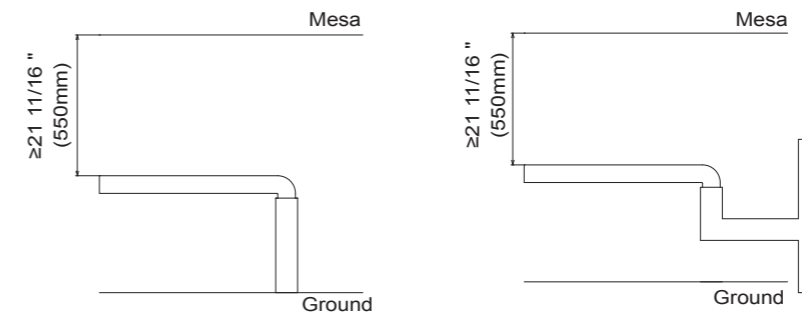

6. Opening size of the countertop and size requirements in the cupboard



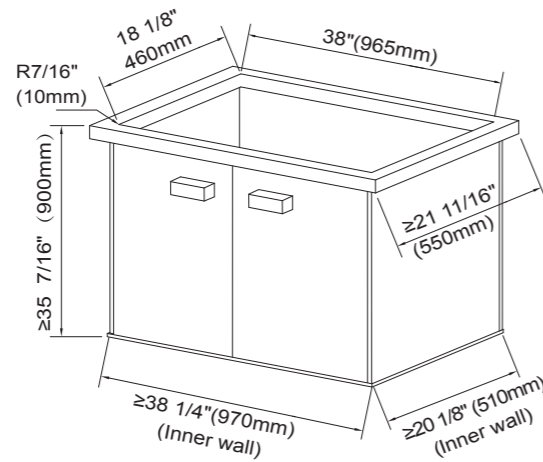





Opening size of the countertop			Inner wall size of cupboard		
Length	Length	Length	Length	Length	Length
38"	18 1/8"	7/16"	≥38 1/4"	≥20 1/8"	≥35 7/16"



7. After the dishwasher is installed, the whole machine can be taken out from the countertop for future maintenance.
8. There should be at least an 18" space above the countertop so that the door of the dishwasher can be opened normally.

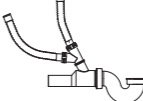
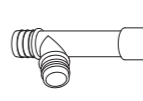
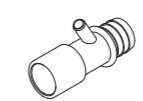

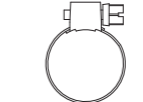

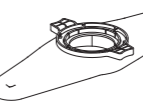
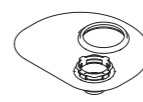

















■ Installation List

Product Packing Box List

Use and Care Manua		1
Installation Manual		1
Warranty Card		1
Vegetable basket		1
Dish rack		1
Sewer hose assembly for functional sink		1
Exhaust tee		1
Electrical lock tee		1
Rubber tube		1
Clamp		5
Connecting tube of the overflow seat- exhaust tee		1
Spray arm		1
Filtration assembly		1







Recommended installation accessories (purchase by oneself)

√: Must ×: No need ○: Optional

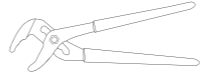
Material	Name and specification	Quantity	Drainage mode	
			Standard Post Sink Strainer in Stainless Steel 9/16"	Kitchen Sink Disposal
	Faucets	1		
	Soap dispenser	1	Choose one from the two ○	
	Air gap	1		
	Stainless Steel Universal Dishwasher Supply Line 3/8"	1		
	Branch Tailpiece 1-1/2"	1	Choose one from the two ○	
	Slip Joint, 1-1/2"	1		
	Right-angle adaptor 1-1/2"	1		
	Slip Joint Nut 1-1/2"	1		
	Tee pipe Sewer and Drain Hub x Hub x Hub Tee 1-1/2 in	1		
	Plastic P-Trap 1-1/2"	1		

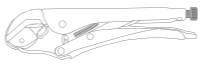
Recommended installation tools

(please use appropriate tools according to actual installation environment)

Material	Specification	Quantity
	PC-1250 Single Stroke Plastic Pipe Cutter	1
	Regular Flat Head screwdriver	1
	Self Adjusting Groove Joint Pliers	1
	Lock Nut Wrench	1
	Glue gun + waterproof and mildew proof glass cement	1
	Glass cement scraper	1
	Tape Measure	1

III. Installation

Product dimensions

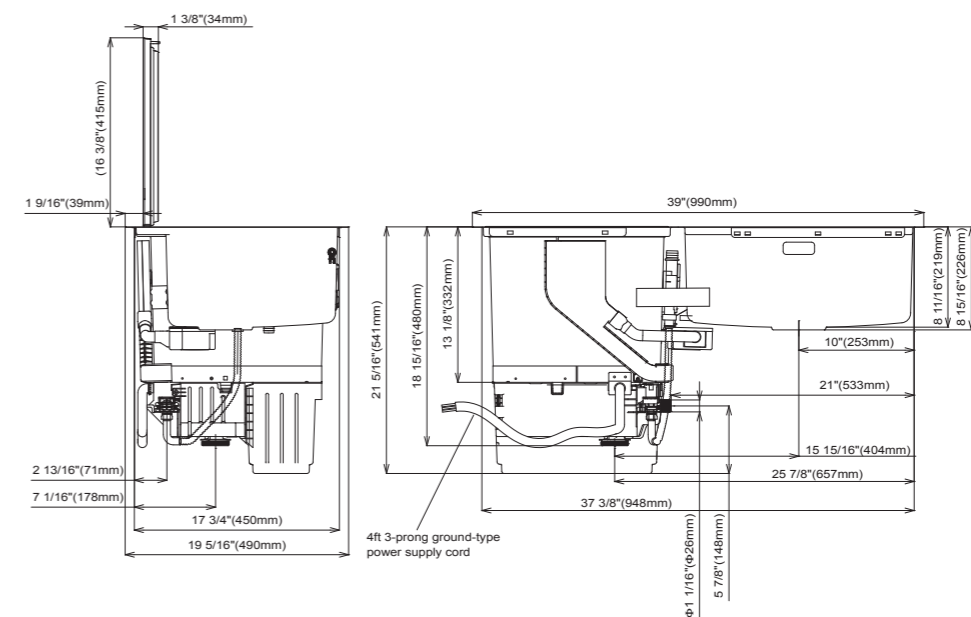

Installation steps

Step 1: Unpack the unit. Take out the dishwasher from the carton and place it on a temporary level and sturdy surface

Step 2: Install water inlet

Connect the inlet hose with 3/8" interface to the joint of the water inlet valve and screw it together.

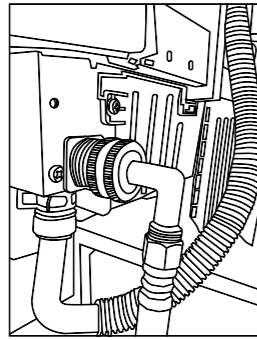

Step 3: Install accessories

1. Take out the rubber hose from the packaging bag and insert one end of the rubber hose into the drip hole under the electrical lock.



2. Put the clamp into the upper end of the electrical lock tee, insert the electrical lock tee into the drop opening of the overflow seat for the functional sink, and lock the clamp.

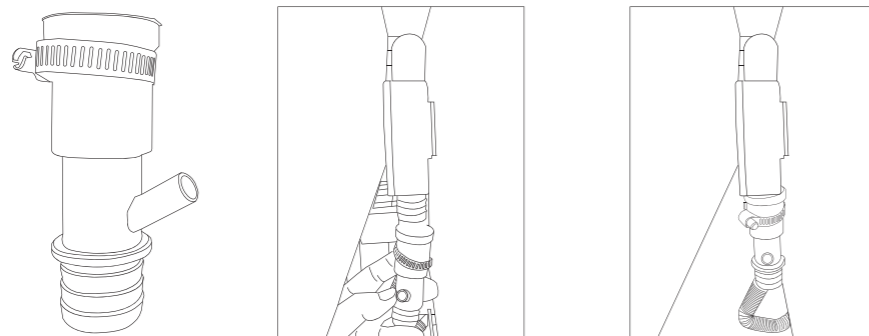

3. Insert the other end of the rubber hose into the electrical lock tee.

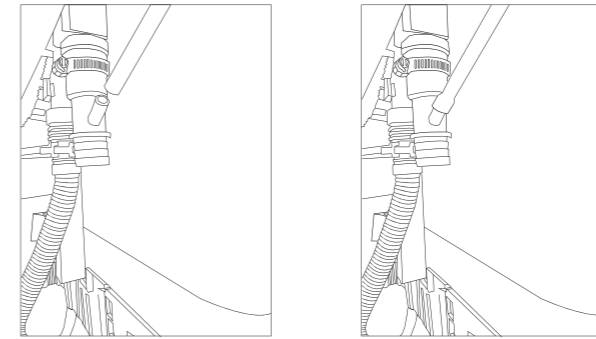

4. Put the clamp into the upper end of the overflow base - exhaust tee, insert the joint pipe of overflow seat and insert the exhaust tee into the drip hole of the overflow base for the sink, then put the overflow base into the exhaust tee, and lock the clamp.

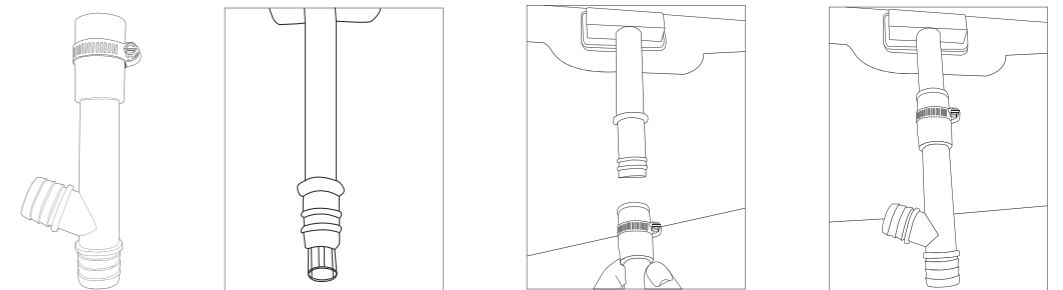

5. Put the clamp into one end of the exhaust pipe, insert into the side hole of the exhaust tee, and lock the clamp.

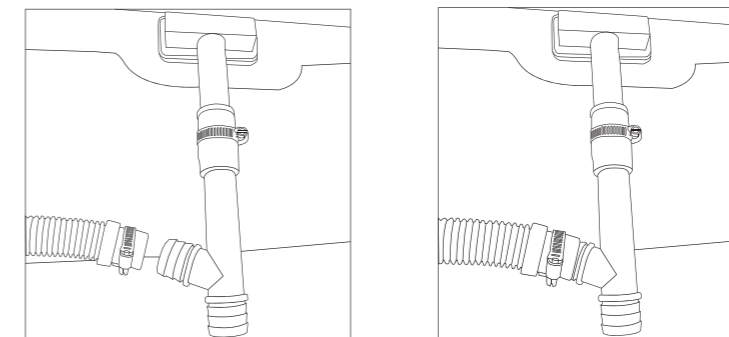

6. Connect and pre-tighten the drain hose assembly for the functional sink and the drain opening of the functional sink. Ensure there is a gasket at the joint.

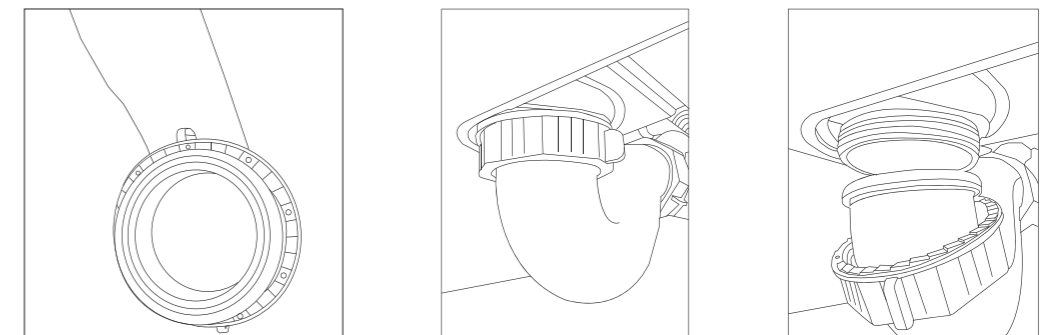

7. Put the clamp into the two overflow pipes, insert the shorter one into the drainage opening of electrical lock tee for the functional sink, insert the longer one into the drainage opening of the overflow seat - exhaust tee, and lock the clamp.

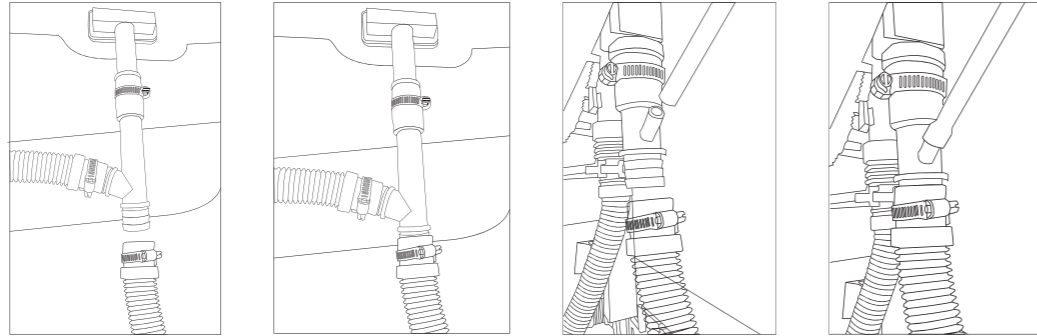

Step 4: Install the faucet and tee

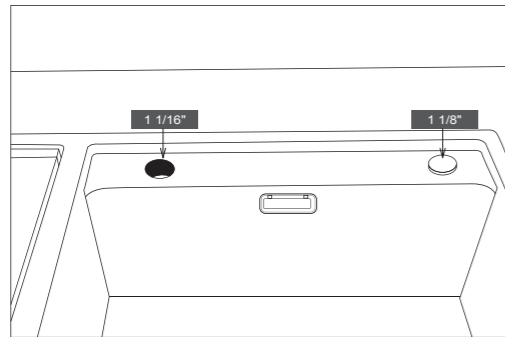

1. Install the faucet and fasten it.
2. Collect the tee at the angle valve of cold water.

Step 5: Clean and glue the countertop

1. Clean and install the countertop
2. Spray glass cement along the perimeter of the mounting hole edges and ensure there is a plenty and continuous supply.

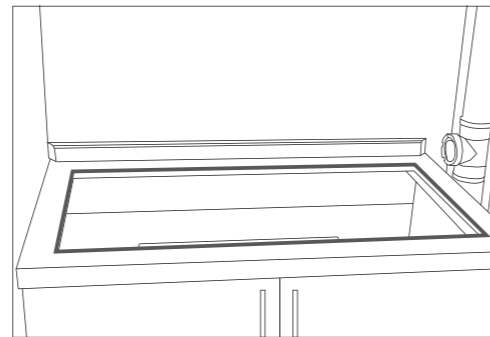

Step 6: Place the sink dishwasher

1. Wear protective gloves and place the sink dishwasher into the opening.
- Note: Do not lift or move the sink dishwasher by the faucet as this will cause damage and possible water leakage.

Step 7: Connect water pipes

1. Correctly connect the cold and hot water pipes of the faucet.
 2. Connect the water inlet of the sink dishwasher and cold water valve tee, and screw it down.
- Note: Only cold water can be supplied to the water inlet of the dishwasher.
3. Open the angle valve and ensure there is no leakage at each joint.

Step 8: Connect power supply

1. Cut off power supply of the electrical box
2. Connect the power cable of the sink dishwasher and the cable in the electrical box, and take the necessary insulation protection measures

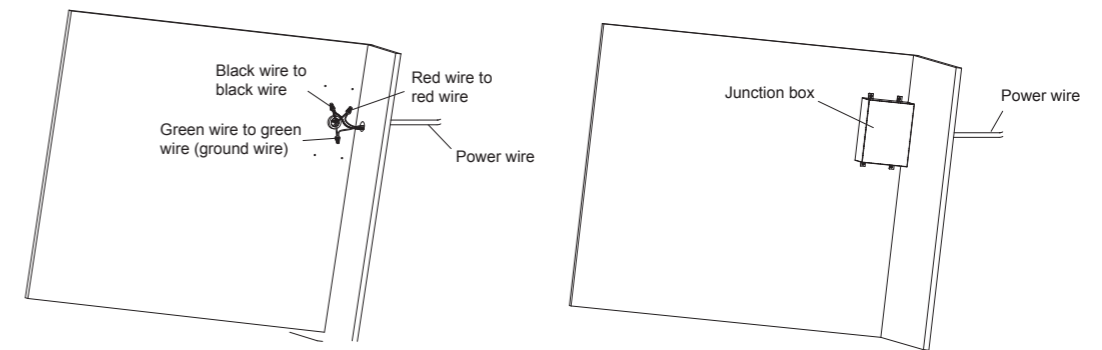

Note: The null line and live wire MUST be connected correctly and have a reliable ground.

Step 9: Install the drainer or waste disposer

Drainer:

- ◆ 1. Correctly install the drainer, connect with the drain hose of the sink dishwasher and ensure tightness and no leakage.

Note:

- ◆ If the pipeline needs to be shortened, cut C end, cutting length $\leq 2'$.
- ◆ If the pipeline needs to be lengthened, unscrew the thread of D end and pull it out, pull-out distance $\leq 1'$.

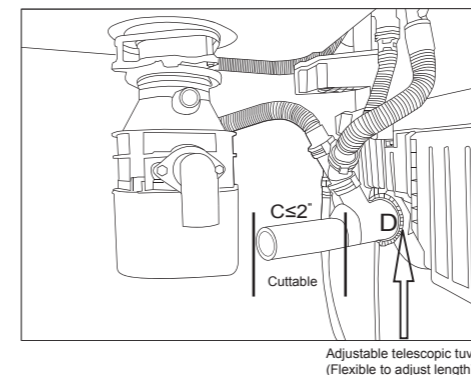

- ◆ Ensure the drain hose keeps vertical or horizontal state

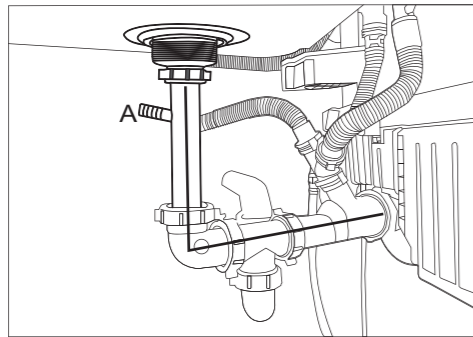

(Other pipelines of air gap can be connected at A. If there is no such requirement, please seal it or directly use the pipeline without A interface)

◇ Kitchen Sink Disposal

1. Correctly install the kitchen Sink Disposal and ensure it's installed in place, without leakage.
2. Adjust the water outlet of the kitchen Sink Disposal and tightly connect it with the drain hose of the sink dishwasher, without leakage.

Note:

- ◆ If the pipeline needs to be shortened, cut C end ($\leq 2''$).
- ◆ If the pipeline needs to be lengthened, unscrew the thread of the D end and pull it out, pull-out distance $\leq 1''$.

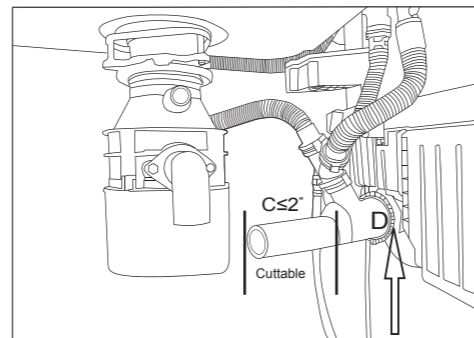

Adjustable telescopic tube
(Flexible to adjust length)

- ◆ Ensure the drain hose keeps vertical or horizontal state

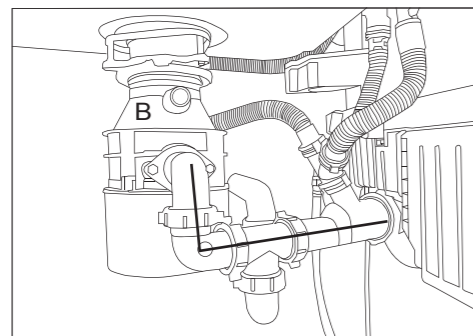

(Air Gap or other pipelines can be connected at B. If there is no such requirement, please seal it)

Step 10: Check the pipeline

1. Check whether the pipeline connected with the sink has leakage.
 2. Check whether the pipeline connected with the functional sink has leakage.
- ◆ Switch on the power supply, Press the open key to open the door and take out all articles in the sink.
 - ◆ Press the strength key for a long time to close the valve under the standby (black screen) mode, fill the overflow opening with water, and check the functional sink and the drain hose for leaks.
 - ◆ Press the water level key for a long time to open the valve and drain water, and check each joint of the drain hose for leaks.

Step 11: Final Steps

1. Spray glass cement along the product edge.
2. Place the filter plate assembly together

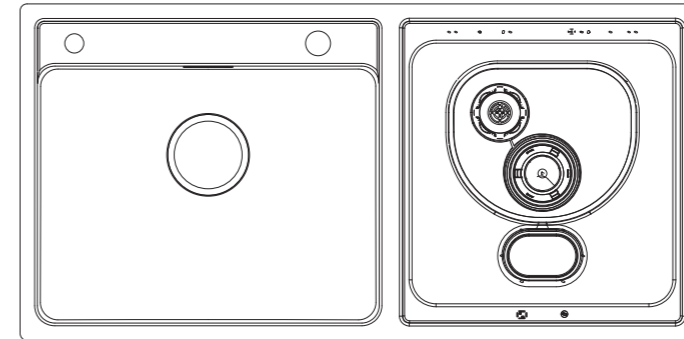

3. Install the spray arm: Pinch the gray locking tab under the spray arm, place it to the position shown in the picture and rotate clockwise. After hearing "click" sound, Spin the spray arm and ensure smooth rotation.

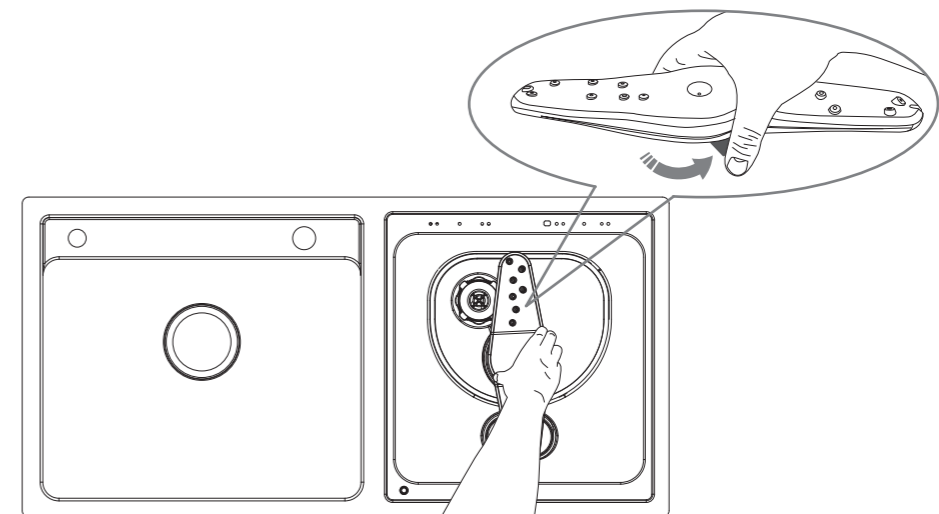

4. Installation Complete

FOTILE

Manual de Instalaciones

Guárdelo en un lugar seguro
para futuras consultas

Lea atentamente este
manual de operación
antes de utilizar el producto.

Fregadero lavavajillas

SD2F-P1X
SD2F-P1XL

CONTENTS

Estimado cliente,

Gracias por elegir los productos para lavaplatos fregadero FOTILE fabricados por FOTILE. Lea atentamente las instrucciones de instalación antes de realizar la instalación. Para cualquier consulta, llame a la línea directa de servicio FOTILE al 1-888-315-0366.

Contenido ----- 1

Instrucciones de seguridad ----- 2

Requisitos de instalación ----- 3

 Lista de instalación ----- 5

 Lista de empaque del producto ----- 5

 Materiales auxiliares para la instalación ----- 6

 Herramientas de instalación ----- 7

Instalación ----- 7

 Dimensiones del producto ----- 7

 Pasos de instalación ----- 8

I. Instrucciones de Seguridad

Para evitar lesiones y daños a la propiedad de los usuarios y otras personas, lea y siga todas las instrucciones y advertencias de seguridad.

1. El personal que instale este producto debe tener conocimientos básicos de mecánica, electricidad y fontanería. Este producto debe ser instalado por fontaneros profesionales certificados.
2. El instalador es responsable de realizar la instalación correcta, cualquier avería del producto provocada por una instalación incorrecta no está cubierta por la garantía de FOTILE.
3. Desconecte la corriente antes de instalar el producto para evitar descargas eléctricas.
4. No moje el cable de alimentación, el enchufe, los conectores u otras piezas eléctricas, ya que puede provocar una descarga eléctrica u otros daños.
5. No modifique, estire o anude el cable de alimentación ni coloque objetos pesados sobre él. De lo contrario, puede dañar el cable de alimentación y provocar una descarga eléctrica, incendio, etc.
6. No toque el cable de alimentación ni las piezas eléctricas con las manos mojadas ya que podría provocar una descarga eléctrica.
7. El lavaplatos fregadero debe estar conectado a una toma de corriente con conexión a tierra. Si no tiene una toma de corriente con conexión a tierra, solicite a un electricista certificado que le instale una. De lo contrario podría provocar descargas eléctricas y lesiones.
8. Si el cable de alimentación está dañado, los técnicos de servicio de Fotile deben reemplazarlo para evitar peligros.
9. Durante la instalación, preste atención a los bordes y esquinas del fregadero para evitar arañazos.
10. Solo se puede suministrar agua fría a la entrada de agua del lavaplatos fregadero Fotile. El suministro de agua caliente afectaría a la función de limpieza de frutas y verduras. El lavaplatos fregadero FOTILE utiliza su propio elemento calefactor para calentar el agua y lavar la vajilla.
11. No permita que los niños jueguen con la película de plástico u otros componentes del embalaje que podrían provocar asfixia o incluso la muerte.
12. La encimera en la que se instala el producto debe tener la resistencia suficiente para soportar 220 lbs (100Kg). Siga todas las instrucciones de montaje para instalarlo firmemente en la encimera correctamente.
13. La encimera en la que se instale el producto debe ser de materiales resistentes a la temperatura y la humedad.
14. Durante la instalación del producto, el fregadero funcional debe mantener una distancia de 11 13/16" (300 mm) o más del medidor de gas y la tubería de gas. La caja de conexiones debe estar a una distancia de 5 15/16" (150 mm) o más del medidor de gas y la tubería de gas.
15. Cumpla con todas las leyes y regulaciones locales para realizar la conexión de la manguera de drenaje.
16. Guarde este manual de instalación para futuras consultas.

II. Requisitos de instalación

Para evitar lesiones y daños materiales a los usuarios y otras personas, lea y observe todas las instrucciones y advertencias de seguridad.

1. No debe instalar en el armario objetos que obstruyan el fregadero y la línea de drenaje, como una línea de gas o un medidor de gas;

Manguera y equipo		Distancia neta desde la manguera de gas	
		Paralela	Cruzada
Equipo eléctrico	Alambre o cable aislado expuesto	9 7/8"(250mm)	3 15/16"(100mm)
	Alambre expuesto con voltaje inferior a 1,000V	39 3/8"(1,000mm)	39 3/8"(1,000mm)
	Cuadro de distribución o tablero de distribución, medidor de electricidad	11 13/16"(300mm)	No permitido
	Alambre o cable aislado expuesto	5 15/16"(150mm)	No permitido

2. El suministro de agua y el enchufe de alimentación se deben colocar en el armario (o en el armario adyacente).
3. Se debe proporcionar una fuente de alimentación de 240V/60Hz. Se debe utilizar un cable con un diámetro de más de 16AWG (1.5 mm²) y una conexión fiable a tierra.
4. La presión de instalación de la vía de agua debe cumplir con los requisitos de 20.3 psi-145.04 psi.
5. Requisitos de altura de la manguera de desagüe: la altura desde la parte superior de la encimera hasta la manguera de desagüe debe ser mayor o igual a 21 11/16"(550 mm).

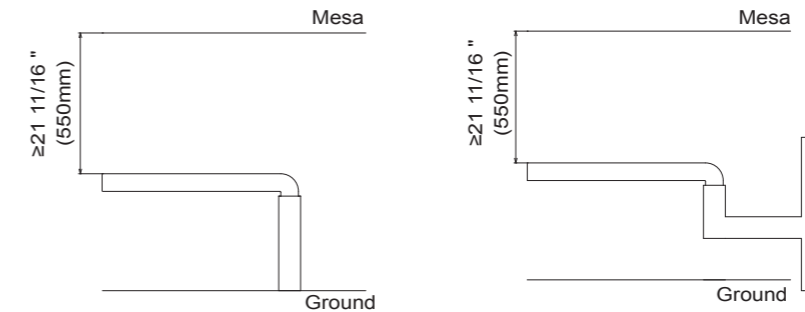

6. Tamaño de la abertura de la encimera y requisitos de tamaño en el armario

Tamaño de la abertura de la encimera			Tamaño de la pared interior del armario		
Largo	Ancho	Ángulo R	Largo	Ancho	Alto
38"	18 1/8"	7/16"	≥38 1/4"	≥20 1/8"	≥35 7/16"

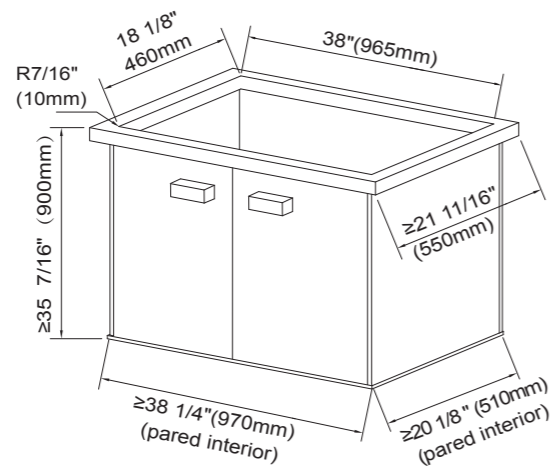

7. Una vez instalado el lavaplatos, se puede extraer toda la máquina de la encimera para su mantenimiento en el futuro.

8. Debe haber un espacio mínimo de 18" por encima de la encimera para poder abrir bien la puerta del lavaplatos. (Consulte la ilustración en la Sección III)





















■ Lista de Instalación

Lista de Caja de Embalaje del Producto

Uso y Cuidado		1
Manual de Instalaciones		1
Tarjeta de garantía		1
Cesta vegetal		1
Estante de rejilla		1
Conjunto de manguera de desagüe para fregadero funcional		1 set
T de escape		1
T de cierre eléctrico		1
Tubo de goma		1
Abrazadera		5
Tubo de conexión del desbordamiento asiento tubo de escape		1
Brazo rociador		1
Conjunto de filtración		1 set



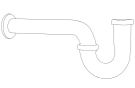



Accesorios recomendados de instalación (no incluidos)

√: Necesario ×: No necesario ○: opcional

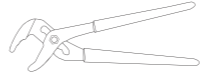
Material	Nombre y especificación	Cantidad	Modo de drenaje	
			Colador de fregadero de acero inoxidable 9/16"	Triturador del fregadero de cocina
	Grifos	1		
	Dispensador de jabón	1	○ Seleccione uno de los dos	
	Cámara de aire	1		
	Línea de suministro estándar universal de lavaplatos 3/8"	1		
	Pieza final de división 1-1/2"	1	○ Seleccione uno de los dos	
	Junta deslizante, 1-1/2"	1		
	Adaptador de ángulo derecho 1-1/2"	1		
	Tuerca de Junta deslizante 1-1/2"	2		
	Tubería en T Eje de desagüe y drenaje x Eje x Eje en T 1-1/2 in	1		
	Colector de plástico en P 1-1/2"	1		

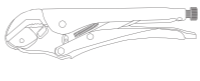
Herramientas de instalación recomendadas

(utilice herramientas adecuadas de acuerdo con el entorno de instalación real)

Material	Especificación	Cantidad
	PC-1250 Cortatubos de plástico de una carrera	1
	Destornillador de cabeza plana	1
	Tenazas autoajustables para juntas de ranura	1
	Llave de tuerca de bloqueot	1
	Pistola de silicona + cemento de vidrio resistente al agua y al moho	1
	Rascador de cemento de vidrio	1
	Cinta métrica	1

III. Instalación

■ Dimensiones del producto

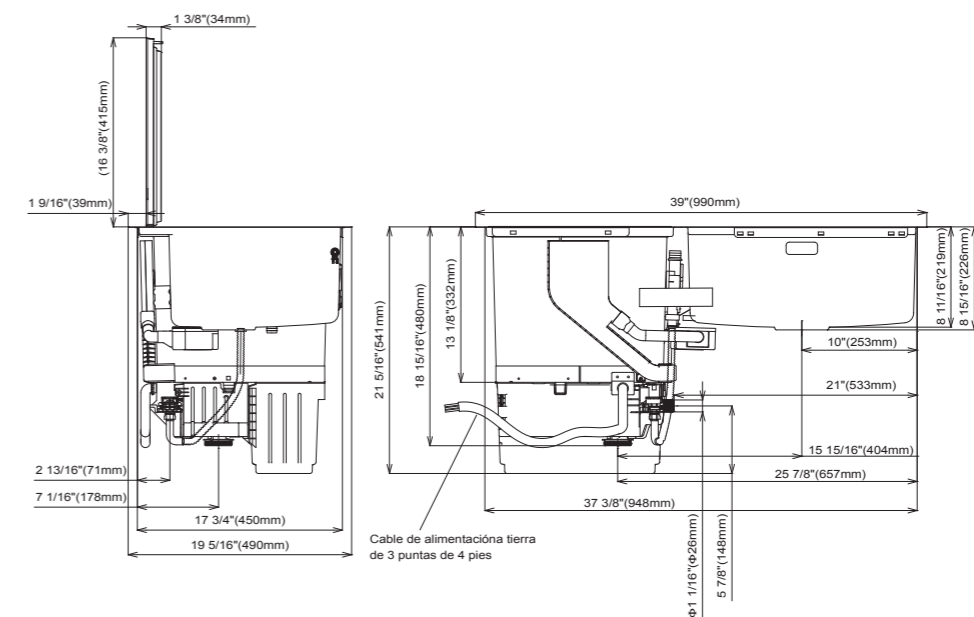

Pasos de instalación

Paso 1: Desempaquete la unidad. Saque el lavaplatos de la caja y colóquelo en una superficie nivelada y resistente.

Paso 2: Instale la entrada de agua

Conecte la manguera de entrada con una interfaz de 3/8" a la junta de la válvula de entrada de agua y atorníllela.

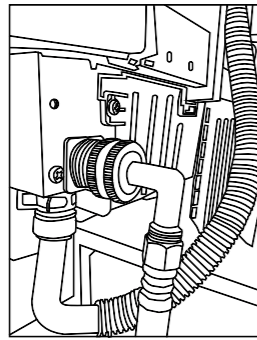

Paso 3: Instale los accesorios

1. Extraiga la manguera de goma de la bolsa de embalaje e inserte un extremo de la manguera de goma en el orificio de goteo debajo de la T de cierre eléctrico.



2. Coloque la abrazadera en el extremo superior del tubo de cierre eléctrico, inserte la T de cierre eléctrico en la abertura de bajada del asiento de desbordamiento para el fregadero funcional y cierre la abrazadera.

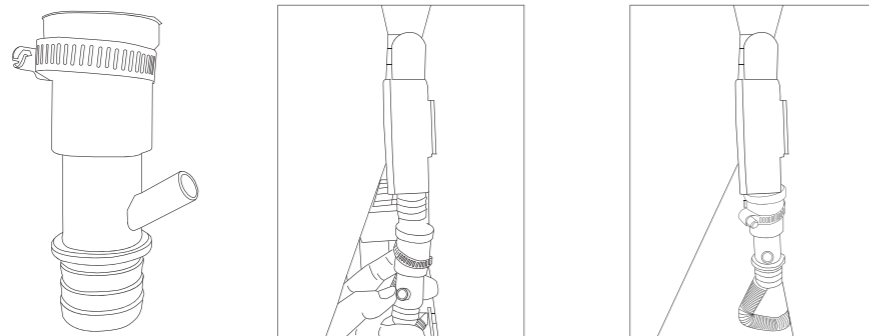

3. Inserte el otro extremo de la manguera de goma en la T de cierre eléctrico.

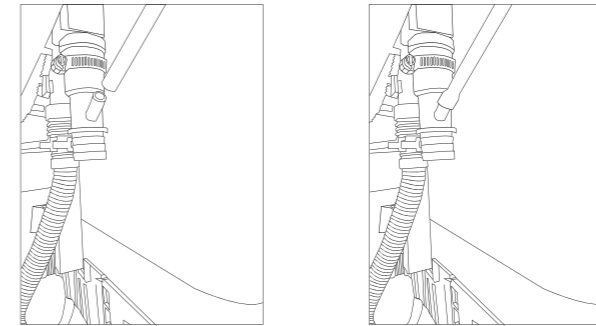

4. Coloque la abrazadera en el extremo superior de la base de desbordamiento - T de escape, inserte el tubo de unión del asiento de desbordamiento e inserte la T de escape en el orificio de goteo de la base de desbordamiento del fregadero, luego coloque la base de desbordamiento en la T de escape y cierre la abrazadera.

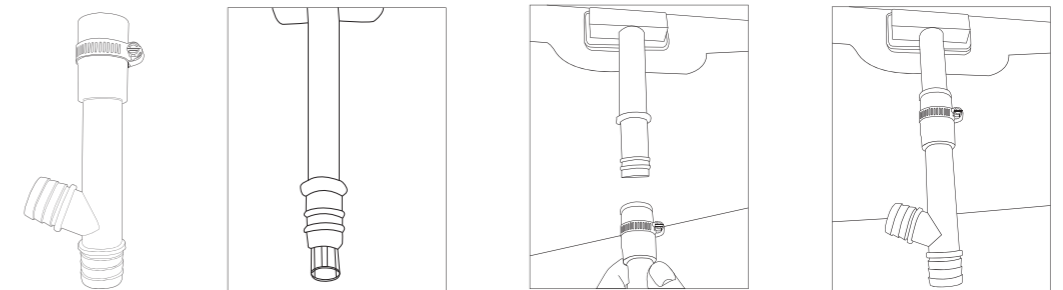

5. Coloque la abrazadera en un extremo del tubo de escape, insértela en el orificio lateral de la T de escape y cierre la abrazadera.

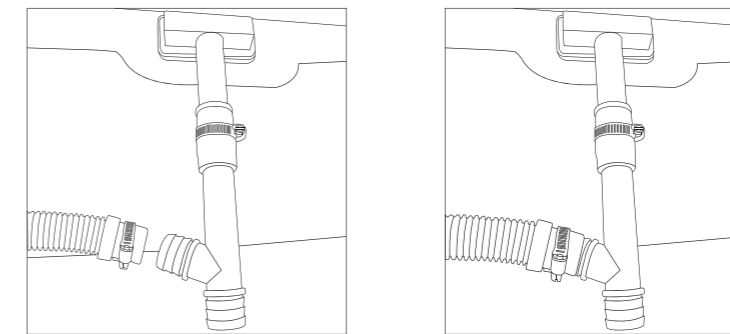

6. Conecte y apriete previamente el conjunto de la manguera de drenaje para el fregadero funcional y la abertura de drenaje del fregadero funcional. Asegure que haya una junta en la unión.

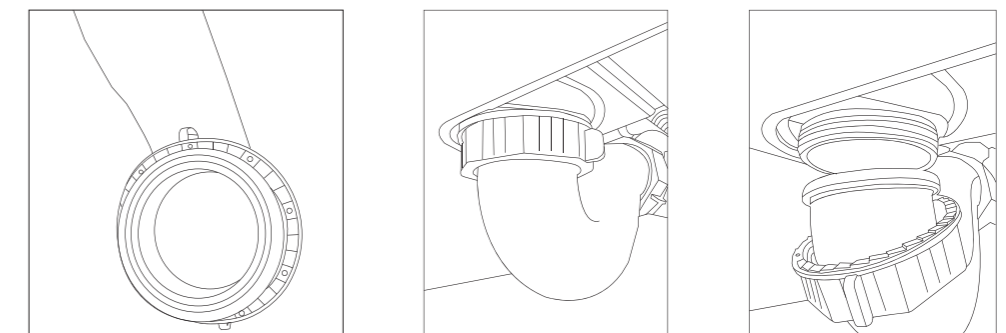

7. Coloque la abrazadera en los dos tubos de desbordamiento, inserte el más corto en la abertura de drenaje de la T de cierre eléctrico para el fregadero funcional, inserte el más largo en la abertura de drenaje del asiento de desbordamiento - T de escape y cierre la abrazadera.

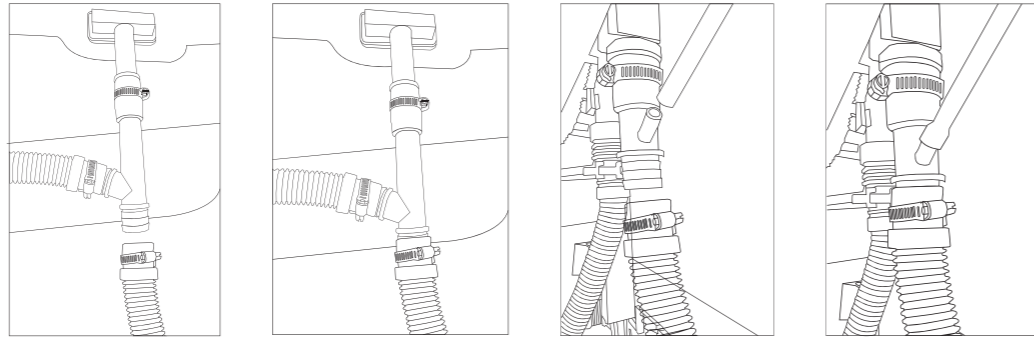

Paso 4: Instale el grifo y la T

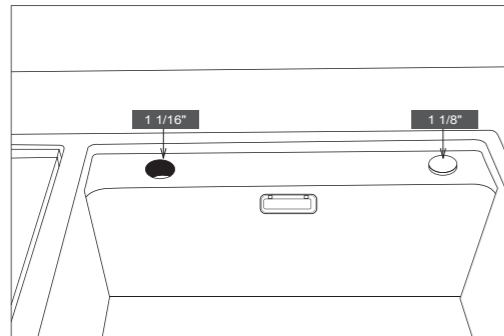

1. Instale el grifo y ajústelo.
2. Recoja la T en la válvula de ángulo del agua fría.

Paso 5: Limpie y pegue la encimera.

1. Limpie e instale la encimera.
2. Pulverice cemento de vidrio por todo el perímetro de los bordes del orificio de montaje y garantice haya un suministro abundante y continuo.

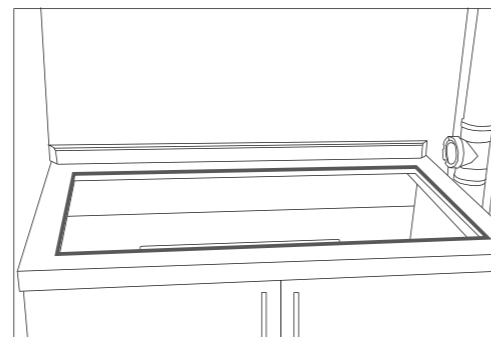

Paso 6: Coloque el lavaplatos del fregadero

1. Utilice guantes protectores y coloque el lavaplatos del fregadero en la abertura.
- Nota: No levante ni mueva el lavaplatos del fregadero agarrando del grifo ya que provocará daños y posibles fugas de agua.

Paso 7: Conecte las tuberías de agua

1. Conecte correctamente las tuberías de agua fría y caliente del grifo.
2. Conecte la entrada de agua del lavaplatos fregadero y la T de la válvula de agua fría y atornille.

Nota: Solo se puede suministrar agua fría a la entrada de agua del lavavajillas.
3. Abra la válvula de ángulo y asegúrese de que no haya fugas en las juntas.

Paso 8: Conecte la fuente de alimentación

1. Corte la fuente de alimentación del armario eléctrico
2. Conecte el cable de alimentación del lavaplatos y el cable en el armario eléctrico, y siga las medidas adecuadas de aislamiento de protección.

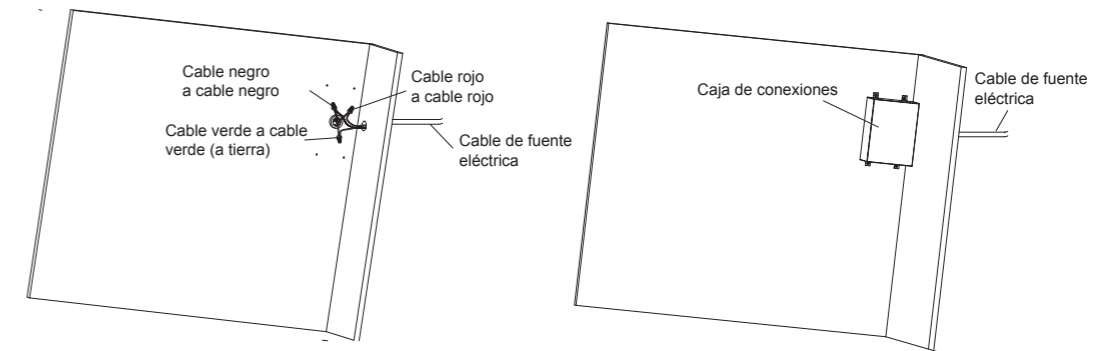

Nota: La línea nula y el cable bajo tensión DEBEN estar conectados correctamente y tener una conexión a tierra fiable.

Paso 9: Instale el escurridor o triturador de desechos.

◇ Escurridor:

1. Instale correctamente el escurridor, conéctelo con la manguera de desagüe del lavaplatos y asegúrese de que quede hermético y que no haya fugas.

Nota:

- ◆ Si precisa acortar la tubería, corte el extremo C, cortando una longitud de ≤ 2 ".
- ◆ Si precisa alargar la tubería, desenrosque la rosca del extremo D y retírela, la distancia de extracción es de ≤ 1 ".

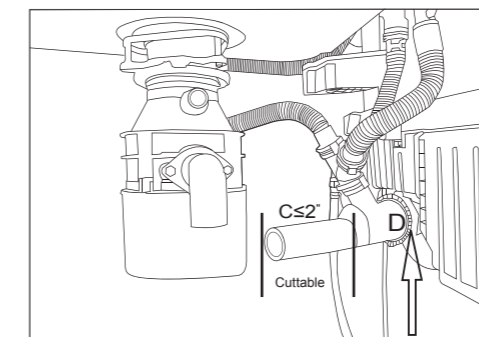

Flexible para ajustar la longitud
(Tubo telescópico ajustable)

- ◆ Asegúrese de que la manguera de drenaje se mantiene en estado vertical u horizontal

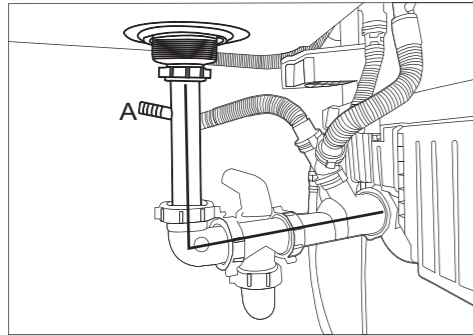

(Puede conectar otras tuberías de la cámara de aire en A. Si no existe este requisito, selle o use directamente la tubería sin una interfaz)

◇ Triturador del fregadero de cocina

1. Instale correctamente el fregadero de cocina y asegúrese de que esté instalado en su sitio, sin fugas.
2. Ajuste la salida de agua del Triturador del Fregadero de cocina y conéctelo firmemente con la manguera de drenaje del lavaplatos del fregadero, sin fugas.

Nota:

- ◆ Si precisa acortar la tubería, corte el extremo C ($\leq 2''$).
- ◆ Si precisa alargar la tubería, desenrosque la rosca del extremo D y retírela, la distancia de extracción es de $\leq 1''$.

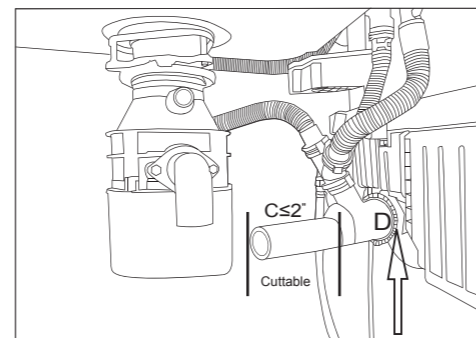

Flexible para ajustar la longitud
(Tubo telescópico ajustable)

- ◆ Asegúrese de que la manguera de drenaje se mantenga en estado vertical u horizontal

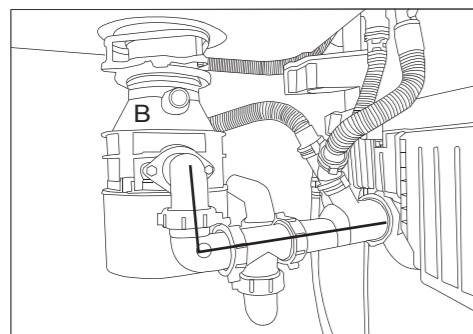

(La cámara de de aire u otras tuberías se pueden conectar en B. Si no existe este requisito, séllelo)

Paso 10: Revise la tubería

1. Compruebe si la tubería conectada con el fregadero tiene alguna fuga.
 2. Compruebe si la tubería conectada con el fregadero funcional tiene alguna fuga.
- ◆ Encienda la fuente de alimentación, presione la tecla de apertura para abrir la puerta y saque todos los elementos del fregadero.
 - ◆ Presione la tecla con fuerza durante un tiempo prolongado para cerrar la válvula en el modo de espera (pantalla negra), llene la abertura de desbordamiento con agua y compruebe si el fregadero y la manguera de drenaje funcionan y si hay alguna fuga.
 - ◆ Presione la tecla de nivel de agua durante un tiempo prolongado para abrir la válvula y drenar el agua del interior, y revise si hay alguna fuga en las uniones de la manguera de drenaje.

Paso 11: Pasos finales

1. Pulverice cemento de vidrio por todo el borde del producto.
2. Coloque el conjunto de la placa del filtro

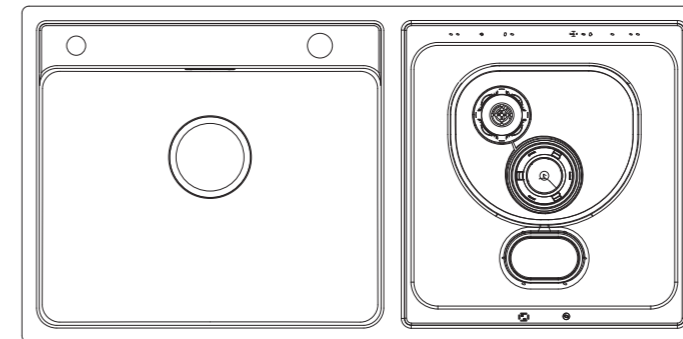

3. Instale el brazo rociador: Apriete la pestaña de bloqueo gris debajo del brazo rociador, colóquelo en la posición que se indica en la imagen y gírelo hacia la derecha. Después de escuchar un "clic", gire el brazo rociador y asegúrese de que gira suavemente.

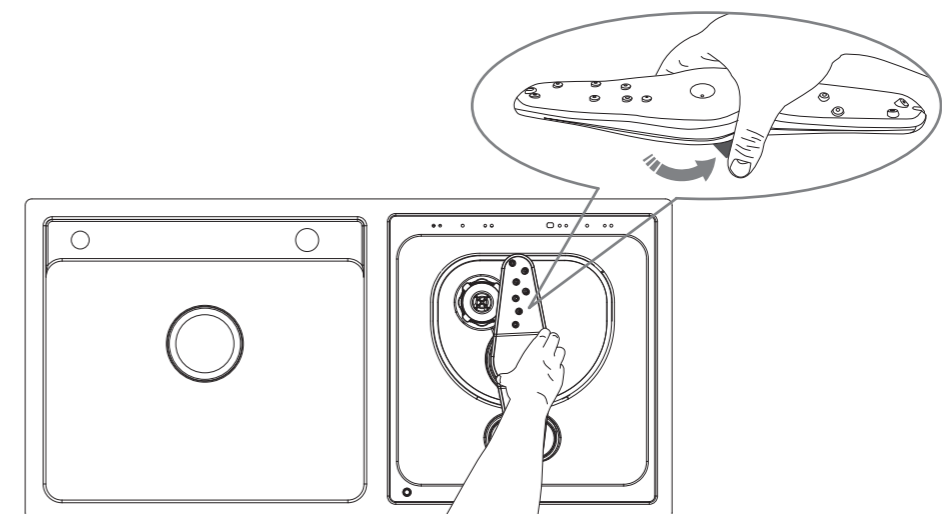

4. Instalación completada

FOTILE

安装指南

请妥善保管，以备参阅

使用产品前请仔细阅读
本说明书

水槽洗碗机

SD2F-P1X
SD2F-P1XL

手册章节

尊敬的用户，您好！

感谢您选购方太公司为您精心制造的方太水槽洗碗机产品，安装前请仔细通读本安装说明，如有任何需要敬请致电。

方太服务热线 1-888-315-0366

目录	1
安全须知	2
安装要求	3
安装清单	5
产品包装清单	5
安装辅材	6
安装工具	7
安装	7
产品尺寸	7
产品步骤	8

一、安全须知

为了避免对使用人员及其他人员造成危害及财产损失，如下均为有关安全的重要事项，敬请严格遵守，并在充分理解内容的基础上正确使用。

- 1、安装本产品须有基本的机械、电气、管道技能技术，请持证的专业水管工来安装。
- 2、正确的安装是安装者的责任，如因安装不当导致的产品故障将不在方太保修范围内。
- 3、在提供安装服务之前必须切断电源以免触电。
- 4、严禁电源线、接插件等电器部件沾水，如果沾水使用可能会导致触电或其它意外伤害。
- 5、请不要对电源线进行改制、拉伸、禁止结扣及施加重物挤压等。否则易导致电源线破损而发生触电和火灾等事故。
- 6、请不要用潮湿的手触摸电源线及电器部件否则易发生触电事故。
- 7、电源接线必须具有可靠的接地线以确保安全。如没有接地线请让持证的电工安装接地线，不得将接地线接于煤气管、自来水管、避雷针及电话线上。接地不良可能引起触电及其他事故。
- 8、如果电源线损坏为了避免危险，必须方太售后人员或专业人员更换。
- 9、方太水槽洗碗机电源链接方式是固定布线连接，应装有符合固定布线规定的单独控制的开关，以满足维修或突发事件时通过此开关切断电源。
- 10、移动产品时要注意槽体边角以免割伤，请带上防护手套。
- 11、方太水槽洗碗机进水必须接入冷水。接入热水会影响果蔬清洗功能。
- 12、请勿让儿童玩耍塑料薄膜和包装箱这可能会产生窒息事故，所以请让包装材料远离儿童，包装材料不是玩具。
- 13、安装产品的台面要有足够支撑220 lbs (100Kg) 的强度，整机必须牢固的安装在台面上。
- 14、本产品是嵌入在橱柜内的，安装产品的橱柜材料必须耐高温耐湿。
- 15、安装产品时，功能槽与燃气表、燃气管道应保持11 13/16"(300mm)以上的距离，接线盒与燃气表、燃气管道应保持5 15/16"(150mm)以上的距离。
- 16、若当地法律法规对下水管连接有其他要求的按其要求连接。
- 17、安装完后请妥善保存本说明书，以备将来参考。

二、安装要求

为避免对用户及其他人员造成人身和财产损失，请阅读并遵守所有安全说明和警告。

- 1、柜体内不能有燃气管、燃气表等干涉功能槽与下水管的物品。

管道和设备		与燃气管道的净距	
		平行铺设	交叉铺设
电气设备	明装的绝缘电线或电缆	9 7/8"(250mm)	3 15/16"(100mm)
	电压小于1000V的裸露电线	39 3/8"(1,000mm)	39 3/8"(1,000mm)
	配电盘或配电箱、电表	11 13/16"(300mm)	不允许
	电插座、电源开关	5 15/16"(150mm)	不允许

- 2、柜体内（或相邻柜）内要有水路和电路的布置。
- 3、要有240V/60Hz电源，需单独布置线径为16AWG (1.5平方)以上的电线，且必须可靠接地。
- 4、安装水路符合要求压力：20.3 psi-145.04 psi
- 5、排水管高度要求：安装台面顶部到下水管的高度应大于等于21 11/16"(550mm)

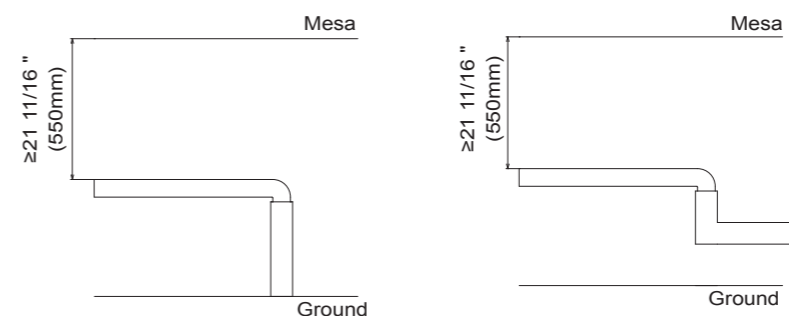

- 6、台面开孔尺寸和柜内尺寸要求。



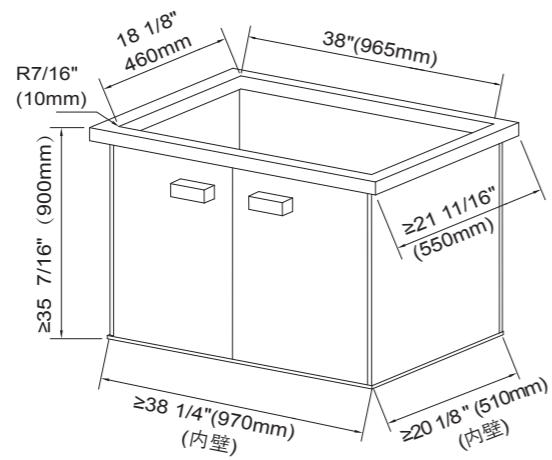



台面开孔尺寸			橱柜内壁尺寸		
长	宽	R角	长	宽	高
38"	18 1/8"	7/16"	≥38 1/4"	≥20 1/8"	≥35 7/16"



- 7. 洗碗机安装后必须考虑后期维修时能从台面把整机拿出来。
- 8. 台面上空间至少要有18"的空间，以便洗碗机门能正常打开。



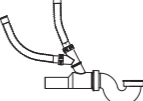
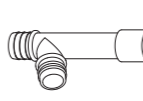

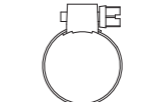
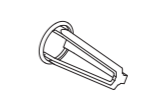
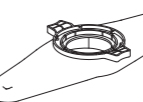
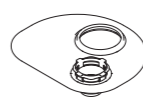



■ 安装清单

产品包装清单

使用与保养说明		1本
安装指南		1本
保修卡		1张
菜篮		1个
碗架		1套
功能槽下水管组件		1套
排气三通		1个
门锁三通		1个
橡胶管		1根
卡箍		5个
溢水座-排气三通连接管		1个
喷淋臂		1个
过滤组件		1套





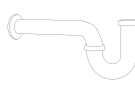

建议安装辅材 (需自行购买)

✓: 必须 ×: 不用 ○: 可选

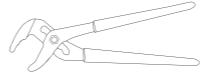
材料	名称及规格	数量	下水方式	
			Standard Post Sink Strainer in Stainless Steel 9/16"	Kitchen Sink Disposal
	Faucets	1	✓	
	Soap dispenser	1	○ Choose one from the two	
	Air gap	1		
	Stainless Steel Universal Dishwasher Supply Line 3/8"	1	✓	
	Branch Tailpiece 1-1/2"	1	○ Choose one from the two	
	Slip Joint, 1-1/2"	1		
	Right-angle adaptor 1-1/2"	1	✓	
	Slip Joint Nut 1-1/2"	1	✓	
	Tee pipe Sewer and Drain Hub x Hub x Hub Tee 1-1/2 in	1	✓	
	Plastic P-Trap 1-1/2"	1	✓	

建议安装工具

(请根据实际安装环境来配置相应工具)

材料	规格	数量
	PC-1250 Single Stroke Plastic Pipe Cutter	1
	Regular Flat Head screwdriver	1
	Self Adjusting Groove Joint Pliers	1
	Lock Nut Wrench	1
	Glue gun + waterproof and mildew proof glass cement	1
	Glass cement scraper	1
	Tape Measure	1

三、安装

■ 产品尺寸

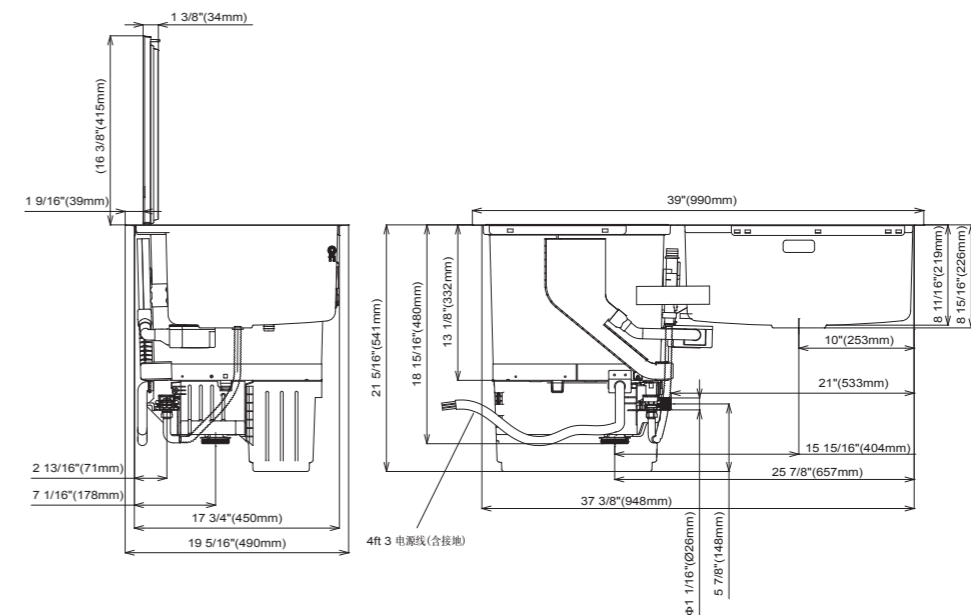

■ 安装步骤

第一步：开箱

从包装箱取出整机，平稳放置。

第二步：安装进水管

把3/8"接口的进水连接管接到进水阀连接处，拧紧。

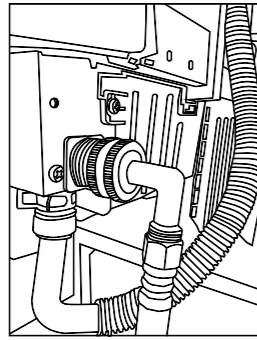

第三步：安装配件

1、从包装袋里取出橡胶管，把橡胶管的一端插入门锁下方的滴水孔。



2、把卡箍套入门锁三通上端，把门锁三通插到功能槽溢水座滴水口，并锁紧卡箍。

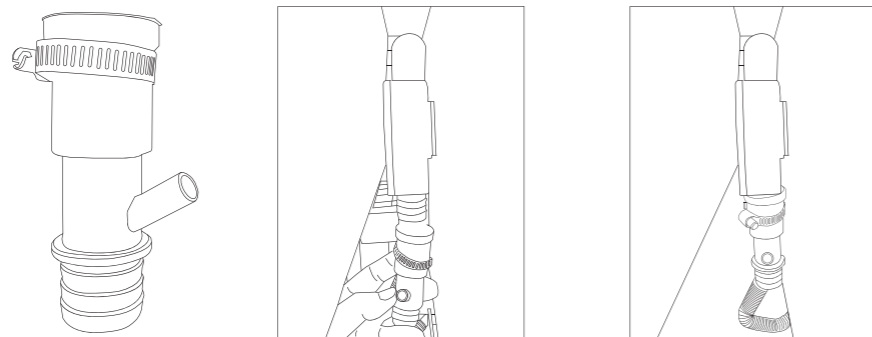

3、橡胶管另一端插入门锁三通上。

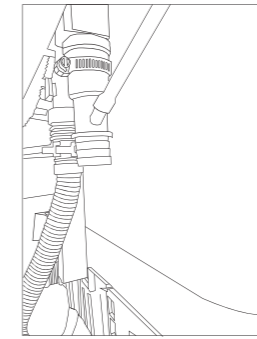
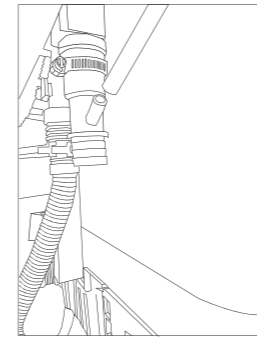

4、把卡箍套入溢水座-排气三通上端，把溢水座-排气三通连接管插到水槽溢水座滴水孔里，然后套上溢水座-排气三通，并锁紧卡箍。

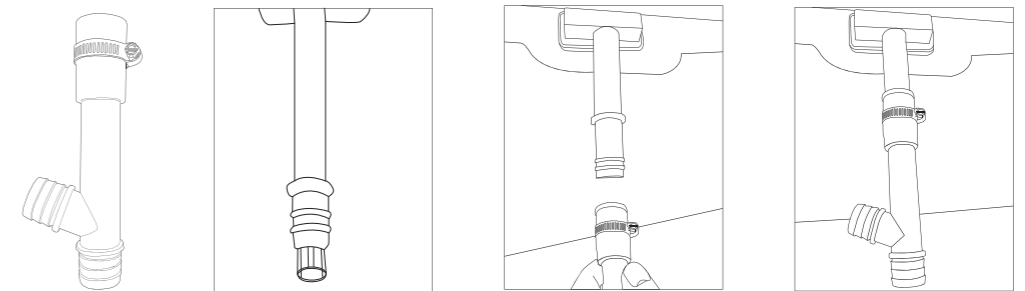

5、把排气管的一端套上卡箍，插到排气三通的侧面孔里，并锁紧卡箍。

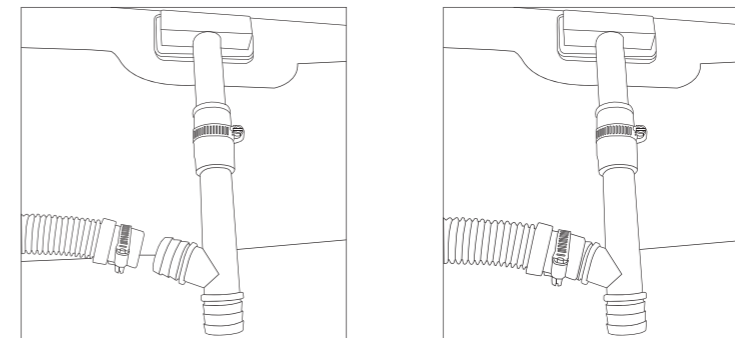

6、把功能槽下水管组件跟功能槽排水口连接预拧紧。确保连接处有密封垫。

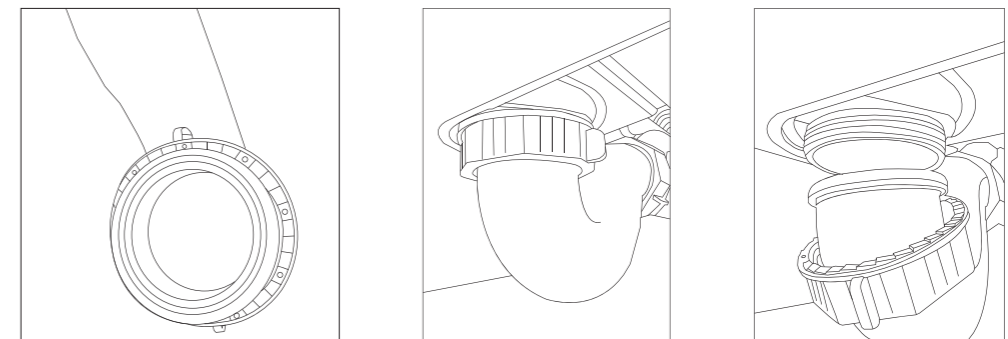

7、把两根溢水管套上卡箍，短的一根插到功能槽门锁三通下水口，长的一根插到溢水座-排气三通下水口，并锁紧卡箍。

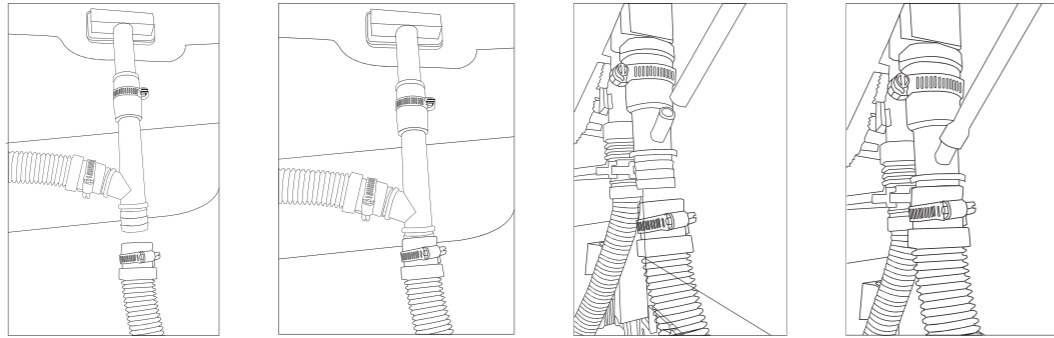

第四步：安装水龙头与三通

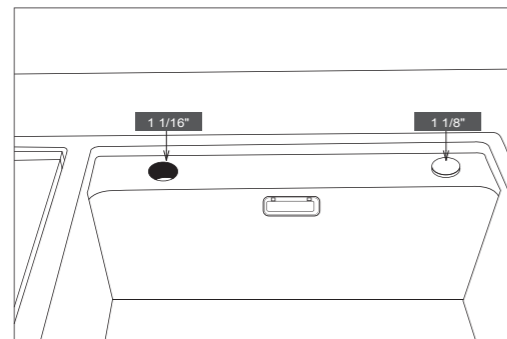

- 1、安装水龙头并紧固。
- 2、在冷水角阀处连接好三通。

第五步：台面清洁、打胶

- 1、清理安装台面。
- 2、沿安装孔边缘打玻璃胶，确保玻璃胶连续不断点。

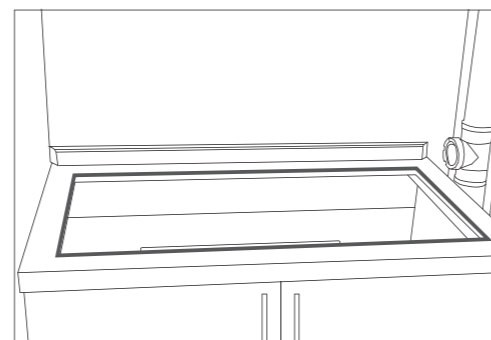

第六步：放置水槽洗碗机

- 1、带上防护手套将水槽洗碗机放入开孔中。
- 注：抬洗碗机时禁止手持水龙头，以免水龙头松脱导致漏水。

第七步：连接水路

- 1、正确连接水龙头冷、热水管。
- 2、连接水槽洗碗机的进水管与冷水阀三通并拧紧。
注：洗碗机进水管必须接冷水。
- 3、打开角阀，确保各连接处无漏水

第八步：连接电源

- 1、切断电器盒电源
- 2、把水槽洗碗机电源线跟电器盒里的电线一一连接并做好绝缘防护

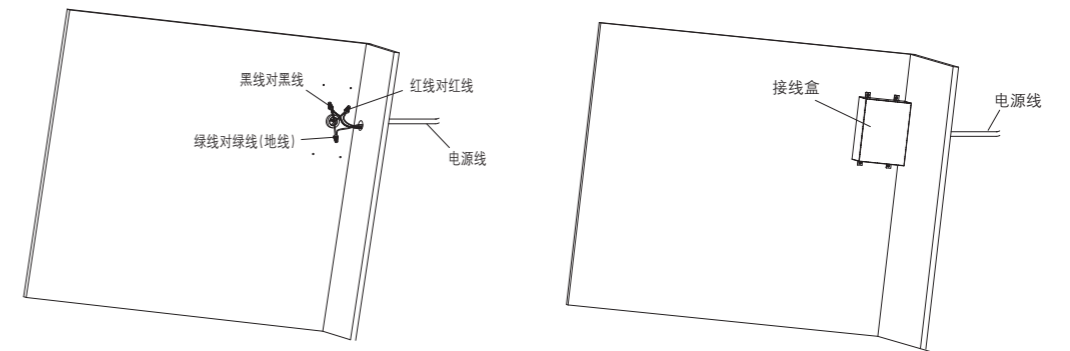

注：电线不能接反，必须可靠接地。

第九步：安装下水器或垃圾处理器

◇ 下水器：

- 1、正确安装下水器，并与水槽洗碗机排水管路相连，确保安装紧密不漏水。

注：

- ◆ 若需减短管路，可裁剪C端，裁剪长度 ≤ 2 "。
- ◆ 若需加长管路，可拧松D端螺纹并拉出，拉出距离 ≤ 1 "。

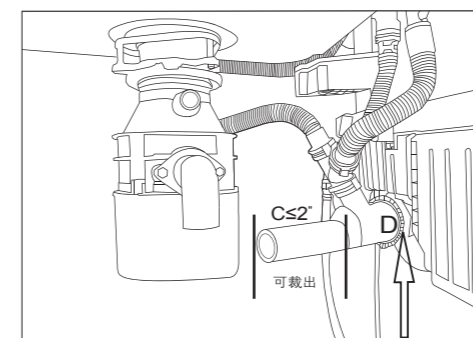

可伸缩调节长短

- ◆ 确保排水管保持垂直或水平状态

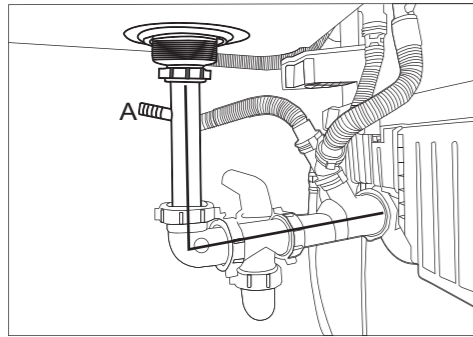

(A处可连接Air Gap其他管路, 若无此类需求, 请将其密封或直接使用无A接口的管路)

◇ 厨余处理器:

- 1、正确安装厨余处理器, 确保安装到位不漏水。
- 2、调整厨余处理器的出水口, 使其与水槽洗碗机的排水管路连接紧密不漏水。

注:

- ◆ 若需减短管路, 可裁剪C端 ($\leq 2''$)。
- ◆ 若需加长管路, 可拧松D端螺纹并拉出, 拉出距离 $\leq 1''$ 。

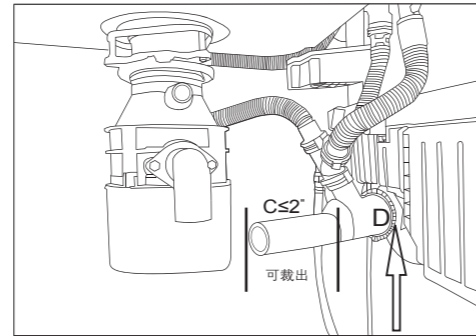

可伸缩调节长短

- ◆ 确保排水管保持垂直或水平状态

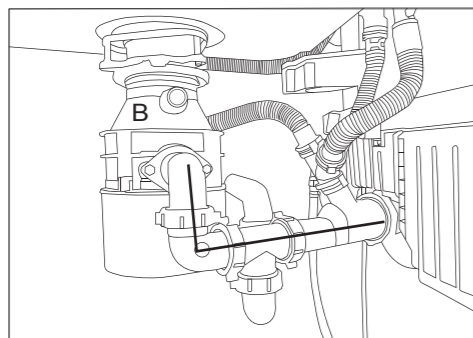

(B处可连接Air Gap或其他管路。若无此类需求, 请将其密封)

第十步: 检查管路

- 1、检查与水槽相连接的管路是否漏水。
- 2、检查与功能槽相连接的管路是否漏水。

- ◆ 接通电源, 按开门键开门, 取出槽内所有物件。
- ◆ 在待机(黑屏)状态下, 长按强度键关阀, 把水放满到溢水口, 检查功能槽与排水管是否漏水。
- ◆ 长按水位键开放水, 同时检查排水管各接口处是否有漏水。

第十一步: 收尾

- 1、沿产品边缘打上玻璃胶, 确保与台面间隙密封。
- 2、放上过滤板组件。

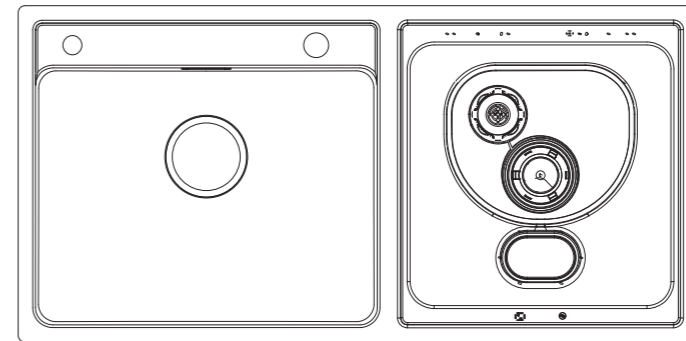

- 3、安装喷淋臂: 捏住喷淋臂下方灰色卡扣, 放至图示位置并顺时针旋转, 听到“咔哒”声后, 拨动喷淋臂, 确保旋转顺畅。

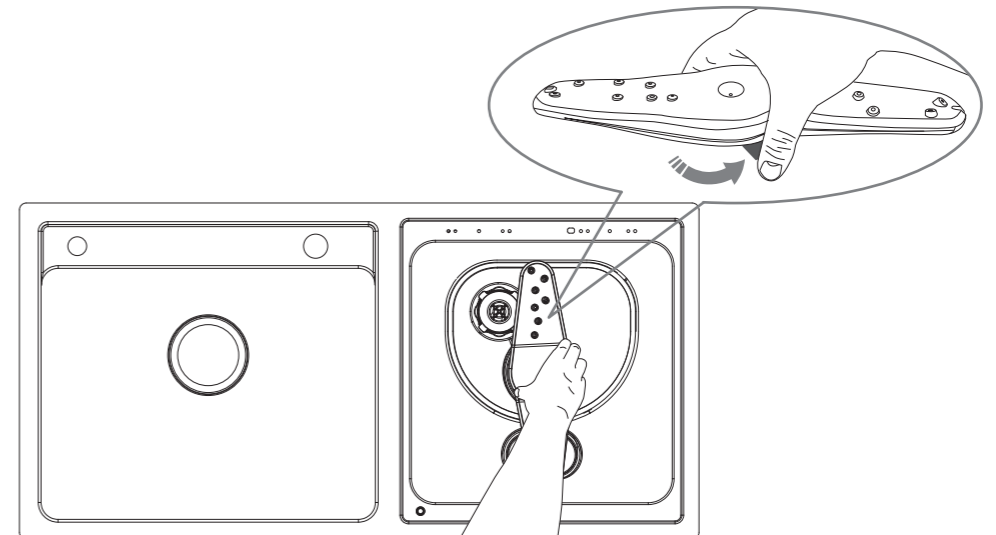

- 4、完成安装。