

FOTILE



EMG9030



EMS9018

A BREATH OF FRESH ENGINEERING™

WHY FOTILE

Trustworthy Brand

- Sold in over 20 countries around the world, and chosen by 10,000+ families daily.
- First Chinese kitchen appliance manufacturer to achieve a revenue of more than \$1.5 billion.
- 3500 technicians in 50 states ensures timely and professional service.
- Leading the research and development of International Standards for Range Hoods.
- Owner of nearly 3,000 kitchen appliance patents, with 400 being invention patents.
- On the list of Asia's Top 500 Brands for 5 consecutive years.

Effective Products

- Patented Wing-Liked Surround Suction Tech, preventing any cooking smoke from escaping.
- Intelli-Pilot System, smart speed adjusting.
- Patented Nautilus Air Passageway, smoother ventilation.
- Brushless centrifugal DC motor, more powerful and quiet.
- Intelligent Air Management detects and exhausts out harmful organic gases automatically.
- Satisfaction rate nearly 95%, leading in the industry.



Member of HVI, the most authoritative and credible institution in North America



reddot



product
design award



Intertek

Toll Free: 888-315-0366

Address: 6 Campus Dr, Suite 210, Parsippany, NJ 07054

Official Website: www.fotileglobal.com

Email: serviceusa@fotile.com



WeChat Service



YouTube



fotile_usa



	EMG9030 Intelli-Pilot System Powerful and Quiet	EMS9018 Auto Turbo System Value Model
Length	36in	36in
Minimum Noise	40dB	43dB
Motor	Brushless DC motor	AC motor
Highest Static Pressure	720Pa	400Pa
Operation	Touch	Touch
Power Level	Auto/Boost & High & Middle & Low	Turbo/Boost & High & Low
Auto Delay	2/5/10 minutes	2 minutes
Impeller	Patented Bio-Impeller	Durable Metal Impeller
Auto Turbo	Y	Y
Intelligent Air Management	Y	N
Intelligent Self-adjusting	Y	N

5-year limited warranty 2 years full warranty. 5 years limited warranty on all parts. Life time warranty on motor.



Unit: in

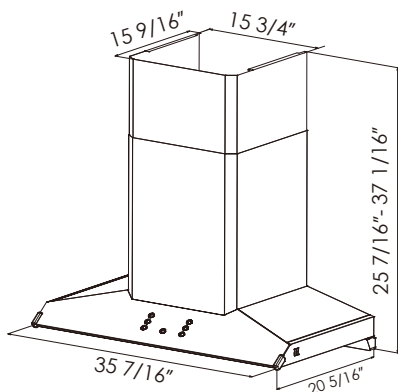

▲ EMG9030 Product Dimensions

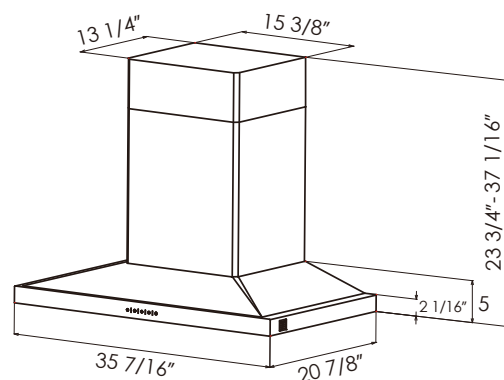

▲ EMS9018 Product Dimensions