

Perimeter Series Range Hoods EMG9030 Spec Sheet

FOTILE
A BREATH OF FRESH ENGINEERING®

FOTILE EMG9030 Perimeter Vent Range hood is the world's first Auto-Adjusting Range Hood with a powerful modern canopy design. Wall mountable, this premium certified Range Hood offers superior smoke, grease, and odor extraction due to its auto adjusting Capture Shield. The EMG9030 not only offers excellent venting performance, it is also exceptionally quiet so you can have a casual conversation as you are preparing a meal. Best of all, this Range Hood can keep your family safe by monitoring the kitchen air quality and automatically venting out any harmful pollutants from the house if



Key Features



Intelligent Self-adjusting Capture Shield Technology for Optimum Extraction Power



Intelligent Air Management System to Keep Families Safe and Protected



Auto Turbo Mode for Instant Additional Power



DC Centrifugal Motor to Provide Smoother and Stronger Ventilation



98% Odor Reduction Rate &
92% Grease Reparatation Rate

Secondary Features

- Auto Delay Shut off
Extracts Lingering Odors
- Powerful LED Light
For Clean Visibility of Your Cooktop
- Large Oil Collection Cup
Detachable and Easy to Clean
- Detachable Capture Shield
Easy to Clean

Perimeter Series Range Hoods EMG9030 Spec Sheet

FOTILE

A BREATH OF FRESH ENGINEERING®

Specifications Table

Model	EMG9030
Certification	ETL, HVI
Width(inch)	35 7/1
Installation	Wall Mount
Max. EQUIV.CFM	1100
Max Static Pressure(Pa)	720
Power Supply(V/Hz)	120/60
Speed Setting	4 + (Turbo)
Min. Noise Level(dB)	41
Illumination(W)	2W × 2 (LED)
Motor	DC Motor
Operation Type	Touch
Delay Shutoff	2/5/10min
Screen Lock	N
Grease Filtration Rate	92%
Odor Reduction Rate	98%
Warranty	Labor: 2 Years Parts: 5 Years(Limited) Motors: Lifetime Limited Warranty

Installation Dimensions

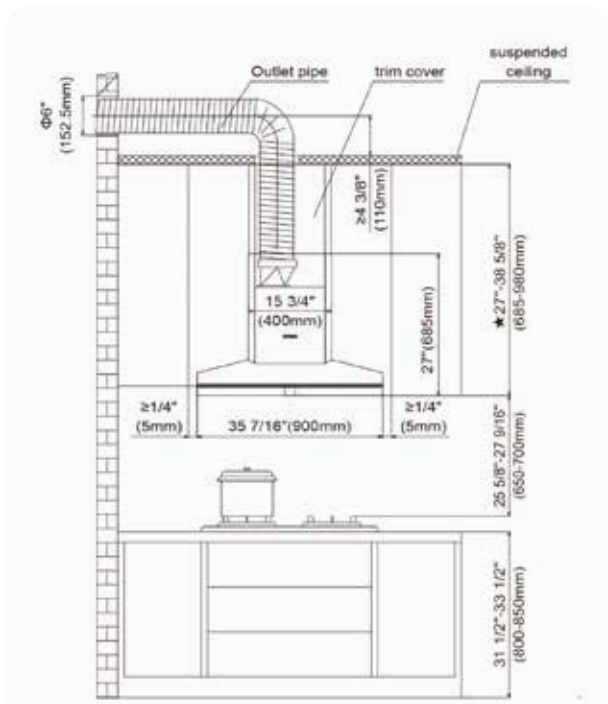

Installation Examples



Slant Vent Series Range Hoods JQG7501 / JQG7501.G Spec Sheet

FOTILE

A BREATH OF FRESH ENGINEERING®

FOTILE JQG7501 and JQG7501.G 30" Slant Vent Range Hoods are powerful and sleek looking. With versatile mounting options whether under cabinet or wall mount, these powerful certified Range Hoods offer superior smoke, grease, and odor extraction due to their unique design, close proximity to the cooktop, and a 90 degree angle automatic open Capture Shield. Best of all, these powerful range hoods not only offer excellent venting performance, they are exceptionally quiet so you can have a casual conversation as you are preparing a meal. Available in Onyx Black Tempered Glass or



JQG7501



JQG7501.G



Key Features



90° Automatic Open Capture Shield to Prevent Smoke from Spreading



Slant Vent Design Ensures Close Proximity to Cooking Surface and Smoke



Dual AC Centrifugal Motors for Exhaustive and Strong Ventilation



98% Odor Reduction Rate & 95% Grease Separation Rate

Secondary Features

- Extra Wide Smoke Inlet
Covers 6 ft² of Cooking Area (5-6 Burners)
- Auto Delay Shutoff
Extracts Lingering Odors After Cooking
- Powerful LED Light
Lights Up Your Cooktop
- Large Oil Collection Cup
Detachable and Easy to Clean

Slant Vent Series Range Hoods JQG7501 / JQG7501.G Spec Sheet

FOTILE

A BREATH OF FRESH ENGINEERING®

Specifications Table

Model	JQG7501 / JQG7501.G
Certification	ETL, HVI
Width(inch)	29 7/8
Installation	Under Cabinet/Wall Mount(Optional Decorative Cover Required)
Max. EQUIV.CFM	850
Max Static Pressure(Pa)	400
Power Supply(V/Hz)	120/60
Speed Setting	3
Min. Noise Level(dB)	39
Illumination(W)	3W × 2 (LED)
Motor	Dual AC Motors
Operation Type	Touch
Delay Shutoff	2min
Screen Lock	Y
Grease Filtration Rate	95%
Odor Reduction Rate	98%
Warranty	Labor: 2 Years Parts: 5 Years(Limited) Motors: Lifetime Limited Warranty

Installation Dimensions

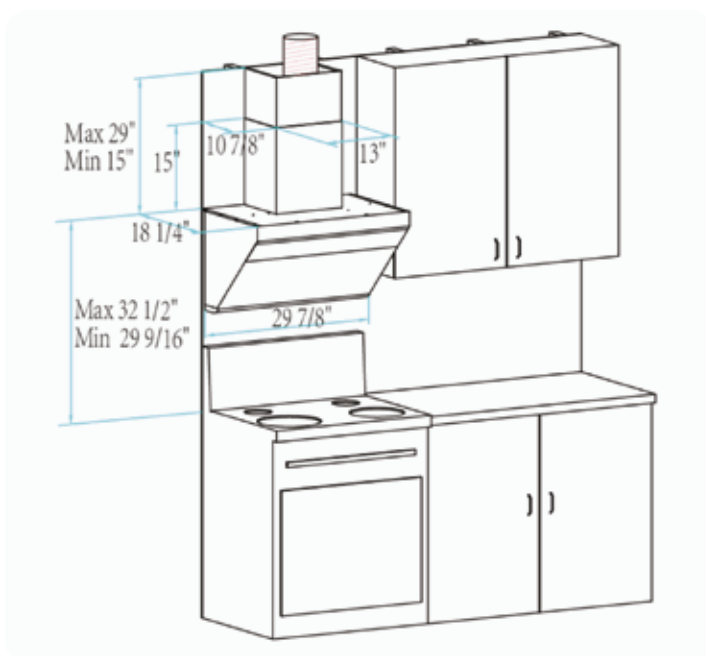

Installation Examples



Perimeter Series Range Hoods EMS9018 Spec Sheet

FOTILE

A BREATH OF FRESH ENGINEERING®

FOTILE EMS9018 Perimeter Vent Range hood is powerful and has a modern canopy design. Wall mountable, this powerful certified Range Hood offers superior smoke, grease, and odor extraction due to its large Capture Shield and M Shape Canopy. Best of all, this powerful range hood not only offers excellent venting performance, it is also exceptionally quiet so you can have a casual conversation as you are preparing a meal. Available in Stainless Steel.



Key Features



Capture Shield Technology to Actively Absorb Smoke



Auto Turbo Mode for Quick Extra Power



97% Odor Reduction Rate & 92% Grease Separation Rate



Covers 7.2 ft² of Cooking Area (5-6 Burners)

Secondary Features

- Auto Delay Shutoff
Extracts Lingering Odors After You Are Done Cooking
- Powerful LED Light
Lights Up Your Cooktop
- Large Oil Collection Cup
Detachable and Easy to Clean
- Detachable Capture Shield
Easy to Clean

Perimeter Series Range Hoods EMS9018 Spec Sheet

FOTILE

A BREATH OF FRESH ENGINEERING®

Specifications Table

Model	EMS9018
Certification	ETL, HVI
Width(inch)	35 7/16
Installation	Wall Mount
Max. EQUIV.CFM	900
Max Static Pressure(Pa)	400
Power Supply(V/Hz)	120/60
Speed Setting	2+Turbo
Min. Noise Level(dB)	44
Illumination(W)	2W (LED)
Motor	AC Motor
Operation Type	Touch
Delay Shutoff	2/5/10min
Screen Lock	Y
Grease Filtration Rate	92%
Odor Reduction Rate	97%
Warranty	Labor: 2 Years Parts: 5 Years(Limited) Motors: Lifetime Limited Warranty

Installation Dimensions

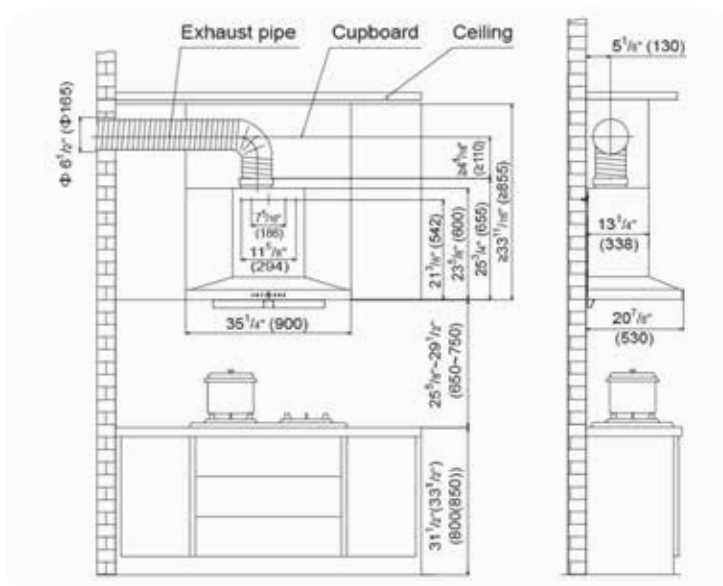

Installation Examples



Slant Vent Series Range Hoods

JQG9001 Spec Sheet

FOTILE

A BREATH OF FRESH ENGINEERING®

FOTILE JQG9001 36" Slant Vent Range Hood is powerful and sleek looking. With versatile mounting options whether under cabinet or wall mount, this powerful certified Range Hood offers superior smoke, grease, and odor extraction due to its unique design, close proximity to the cooktop, and a 90 degree angle automatic open Capture Shield. Best of all, this powerful range hood not only offers excellent venting performance, it's exceptionally quiet so you can have a casual conversation as you are preparing a meal. Available in Onyx Black Tempered Glass.



Key Features



90° Automatic Open Capture Shield to Prevent Smoke From Spreading



Slant Vent Design Ensures Close Proximity to Cooking Surface and Smoke



Dual AC Centrifugal Motors for Exhaustive and Strong Ventilation



98% Odor Reduction Rate & 95% Grease Separation Rate

Secondary Features

- Extra Wide Smoke Inlet
Covers 7.2 ft² of Cooking Area (5-6 Burners)
- Auto Delay Shutoff
Extracts Lingering Odors After Cooking
- Powerful LED Light
Lights Up Your Cooktop
- Large Oil Collection Cup
Detachable and Easy to Clean

Slant Vent Series Range Hoods JQG9001 Spec Sheet

FOTILE
A BREATH OF FRESH ENGINEERING®

Specifications Table

Model	JQG9001
Certification	ETL, HVI
Width(inch)	35 7/8
Installation	Under Cabinet/Wall Mount(Optional Decorative Cover Required)
Max. EQUIV.CFM	850
Max Static Pressure(Pa)	400
Power Supply(V/Hz)	120/60
Speed Setting	3
Min. Noise Level(dB)	39
Illumination(W)	3W × 2 (LED)
Motor	Dual AC Motors
Operation Type	Touch
Delay Shutoff	2min
Screen Lock	Y
Grease Filtration Rate	95%
Odor Reduction Rate	98%
Warranty	Labor: 2 Years Parts: 5 Years(Limited) Motors: Lifetime Limited Warranty

Installation Dimensions

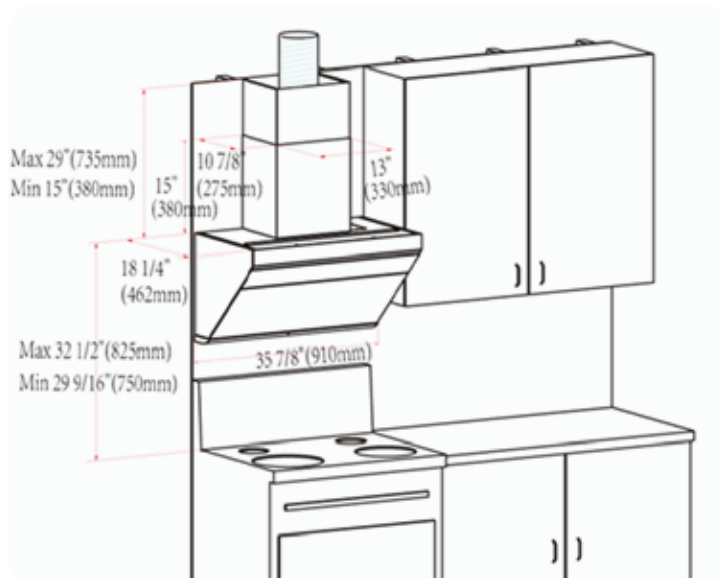

Installation Examples



Slant Vent Series Range Hoods

JQG7505 Spec Sheet

FOTILE

A BREATH OF FRESH ENGINEERING®

FOTILE JQG7505 30" Slant Vent Range Hood is both powerful and sleek looking. With versatile mounting options whether under cabinet or wall mount, this powerful certified Range Hood offers superior smoke, grease, and odor extraction due to its unique design, dual DC centrifugal motors, and a 90 degree angle automatic open Capture Shield. The JQG7505 not only offers excellent venting performance, it is also exceptionally quiet so you can have a casual conversation as you are preparing a meal. Best of all, you can operate this range hood using touch free motion gesture control for easy



Key Features



90° Automatic Open Capture Shield to Prevent Smoke From Spreading



Dual DC Motors for Smoother and Stronger Ventilation



Stir-fry Mode to Provide Instant Powerful Extraction Power



Motion Detection for Hands Free Operation

Secondary Features

- Extra Wide Smoke Inlet
Covers 6 ft² of Cooking Area (5-6 Burners)
- Auto Delay Shutoff
Extracts Lingering Odors After Cooking
- Powerful LED Light
Lights Up Your Cooktop
- Large Oil Collection Cup
Detachable and Easy to Clean

Slant Vent Series Range Hoods JQG7505 Spec Sheet

FOTILE

A BREATH OF FRESH ENGINEERING®

Specifications Table

Model	JQG7505
Certification	ETL, HVI
Width(inch)	29 7/8
Installation	Under Cabinet/Wall Mount(Optional Decorative Cover Required)
Max. EQUIV.CFM	1000
Max Static Pressure(Pa)	540
Power Supply(V/Hz)	120/60
Speed Setting	4
Min. Noise Level(dB)	38
Illumination(W)	3W × 2 (LED)
Motor	Dual DC Motors
Operation Type	Touch + Motion
Delay Shutoff	2min
Screen Lock	Y
Grease Filtration Rate	95%
Odor Reduction Rate	98%
Warranty	Labor: 2 Years Parts: 5 Years(Limited) Motors: Lifetime Limited Warranty

Installation Dimensions

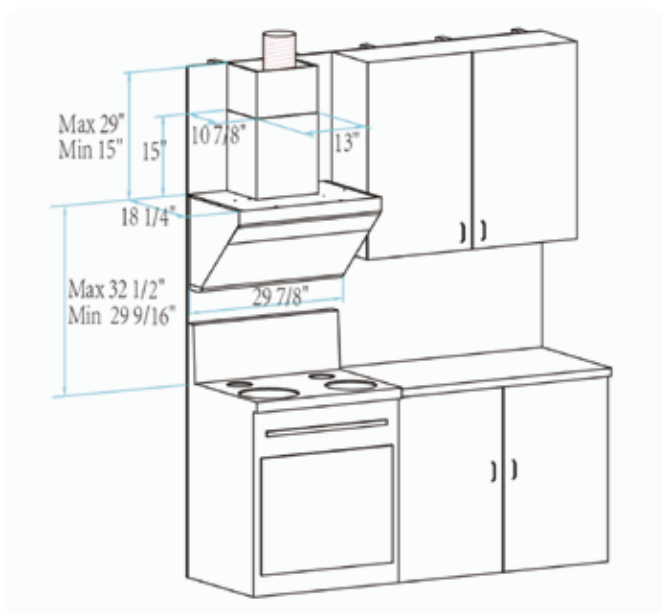

Installation Examples



Slant Vent Series Range Hoods JQG7502/JQG7502.G Spec Sheet

FOTILE
A BREATH OF FRESH ENGINEERING®

FOTILE JQG7502 and JQG7502.G 30" Slant Vent Range Hoods are powerful and sleek looking. With versatile mounting options whether under cabinet or wall mount, these powerful certified Range Hoods offer superior smoke, grease, and odor extraction due to their unique design, close proximity to the cooktop, and a 90 degree angle Capture Shield. Best of all, these powerful range hoods not only offer excellent venting performance, they are exceptionally quiet so you can have a casual conversation as you are preparing a meal. Available in Onyx Black Tempered Glass or Grey Tempered



JQG7502



JQG7502.G

Key Features



90° Open Capture Shield to Prevent Smoke From Spreading



Slant Vent Design Ensures Close Proximity to Cooking Surface and Smoke



Dual AC Centrifugal Motors for Exhaustive and Strong Ventilation



98% Odor Reduction Rate &
95% Grease Separation Rate

Secondary Features

- Extra Wide Smoke Inlet
Covers 6 ft² of Cooking Area (5-6 Burners)
- Push Button Control
Intuitive and Easy Operation
- Powerful LED Light
Lights Up Your Cooktop
- Large Oil Collection Cup
Detachable and Easy to Clean

Slant Vent Series Range Hoods JQG7502/JQG7502.G Spec Sheet

Specifications Table

Model	JQG7502 / JQG7502.G
Certification	ETL, HVI
Width(inch)	29 7/8
Installation	Under Cabinet/Wall Mount(Optional Decorative Cover Required)
Max. EQUIV.CFM	850
Max Static Pressure(Pa)	400
Power Supply(V/Hz)	120/60
Speed Setting	3
Min. Noise Level(dB)	39
Illumination(W)	3W × 2 (LED)
Motor	Dual AC Motors
Operation Type	Push Button
Delay Shutoff	N
Screen Lock	N
Grease Filtration Rate	95%
Odor Reduction Rate	98%
Warranty	Labor: 2 Years Parts: 5 Years(Limited) Motors: Lifetime Limited Warranty

Installation Dimensions

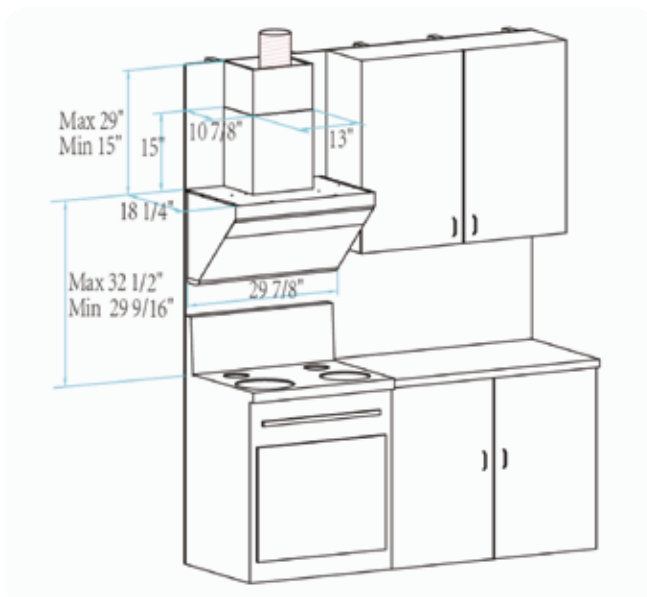

Installation Examples

