

0806 Other High Power Device

HH1002-P

780 nm High Power Tap Isolator Hybrid, 1/99, 20 W, PM

The HH1002-P has very low insertion loss, high return loss, high isolation and high extinction ratio. It can be used for fiber sensor, fiber laser and compact fiber optical system.

FEATURES

- High Return Loss
- Low Insertion Loss
- High Extinction Ratio
- High Isolation

USE IN

- Fiber Sensor
- Fiber Laser
- Compact Fiber Optical System

Center Wavelength	780 nm
Operating Wavelength Range	±5 nm
Excess Loss at 23°C	1.0 dB max.
Signal Tap Ratio	1±0.2% or Specified
Isolation at 23°C	25 dB min.
Extinction Ratio at 23°C	20 dB min.
Return Loss at 23°C	50 dB min.
Optical Power (CW)	20 W max. or Specified
Peak Power for ns Pulse	10 kW or Specified
Tensile Load	5 N max.
Operating Temperature	+10°C to +50°C
Storage Temperature	0°C to +60°C

* With connectors, IL is 0.3 dB higher, RL is 5 dB lower, and ER is 2 dB lower.

* Connector key is aligned to slow axis.

0806 Other High Power Device

MECHANICAL DRAWING

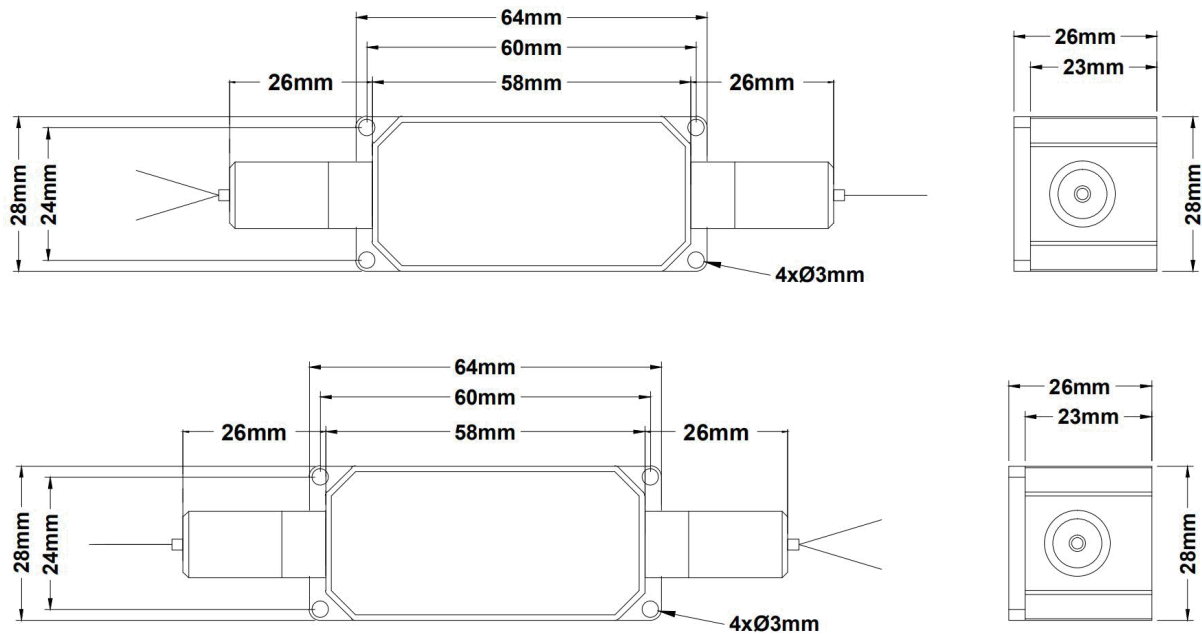

Options for Working Axis

Option 1, 2x1

Input→Output: Fast axis blocked
 Input→Tap: Both axis working

Option 2, 2x1

Input→Output: Both axis working
 Input→Tap: Both axis working

Option 3, 2x1

Input→Output: Both axis working
 Input→Tap: PM to SM, Polarization Insensitive

Option 4, 2x1

Input→Output: SM to SM, Polarization Insensitive
 Input→Tap: SM to SM, Polarization Insensitive

Option 5, 1x2

Input→Output: Fast axis blocked
 Input→Tap: Fast axis blocked

Option 6, 1x2

Input→Output: Fast axis blocked
 Input→Tap: PM to SM, Polarization Sensitive

Option 7, 1x2

Input→Output: SM to SM, Polarization Sensitive
 Input→Tap: SM to SM, Polarization Sensitive