

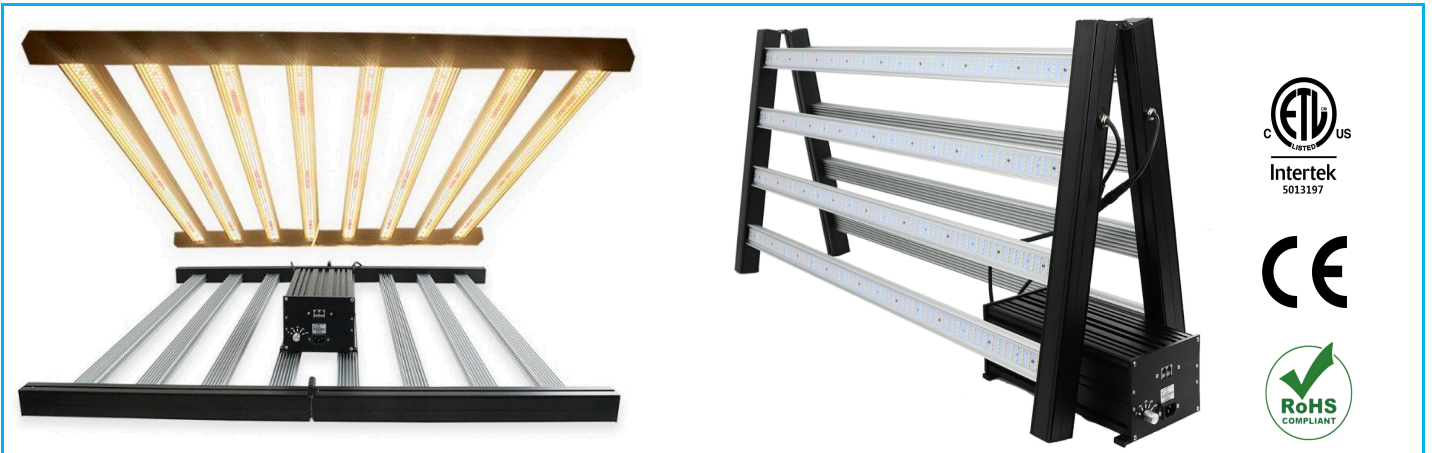

## Foldable Dimmable LED Grow Light

### Product Description

Eagle Star Lighting Foldable Dimmable LED Grow Light series are full spectrum grow lamp fixtures with Samsung +OSROM LED Chips. They can provide more than 60% higher in PPF compared with HID lamps with lower temperature, which increases the production and saves more than 50% power consumption. The fixtures can be used in many applications such as cannabis cultivation, vegetables, greenhouse, ornamental plants and so on. The slim design fixture that is foldable up to 180 degrees, making it small, compact, and easy to install.



- Inventronics driver
- Samsung LM561C s6+Osram Chips
- Full Spectrum red+white+660nm+730nm
- Input voltage 100-277VAC 50Hz/60Hz
- Ideal Working time: 10-14hours;
- Big&wide aluminum body with great heat dissipation
- The fixture can be connected one by one
- 0-10V/APP/WIFI/Computer/Control Table+RJ14
- Easy installation and maintenance
- Biggest Footprint: 4 ft\*4 ft. Suitable for at least 2-4 plants;
- Certificate: CE RoHS ETL cETL

### Product Parameters

Model NO.	ES-GL600A01-YY	ES-GL800A01-YY	ES-GL1000A01-YY
Rated Power	600W	800W	1000W
LED Chips	Samsung LM561C s6+Osram Chips		
Bars Qty	6 pieces	8 pieces	10 pieces
Chips Qty	264piece x6	264piece x8	264piece x10
PPF	1772 $\mu\text{mol/s}$	1862 $\mu\text{mol/s}$	2094 $\mu\text{mol/s}$
Efficacy	2.8-3.0 $\mu\text{mol/J}$	2.8-3.0 $\mu\text{mol/J}$	2.8-3.0 $\mu\text{mol/J}$
Input Voltage	100-277VAC 50Hz/60Hz		
Color Ratio	Full Spectrum red+white+660nm+730nm		
Working Environment	-20°C~+40°C 45%~95%RH		
Certifications	CE, RoHS, ETL, cETL		
Product Size	1100*1100*80mm		
G.W	19.6kg(43Lbs)	22.6kg(49.7Lbs)	27kg(59.4Lbs)
Carton Size	1145*620*190mm		
Replacement	1000W MH	1500W MH	2000W MH
Warranty	5 years		

## Product Size

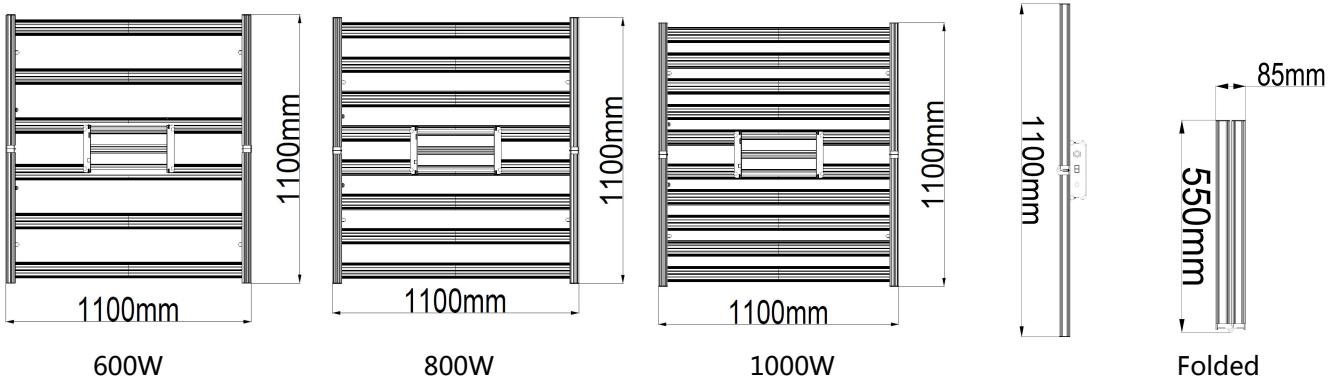

## Product Details

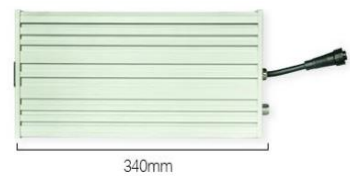
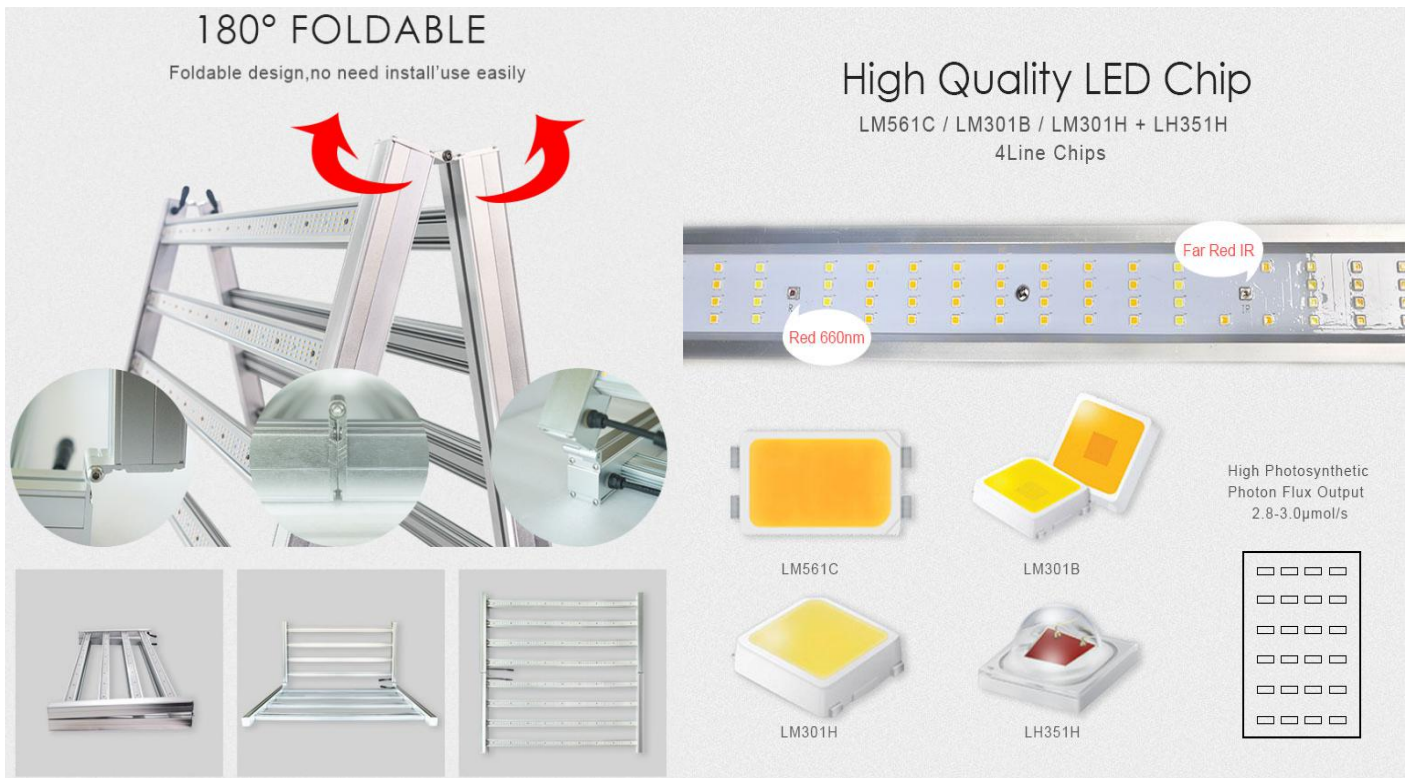

## Product Pictures



600W

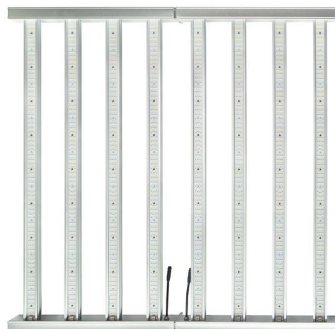

800W



1000W

# Test Report

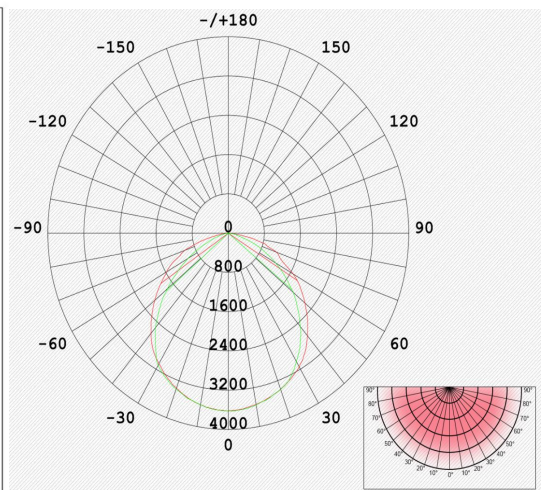
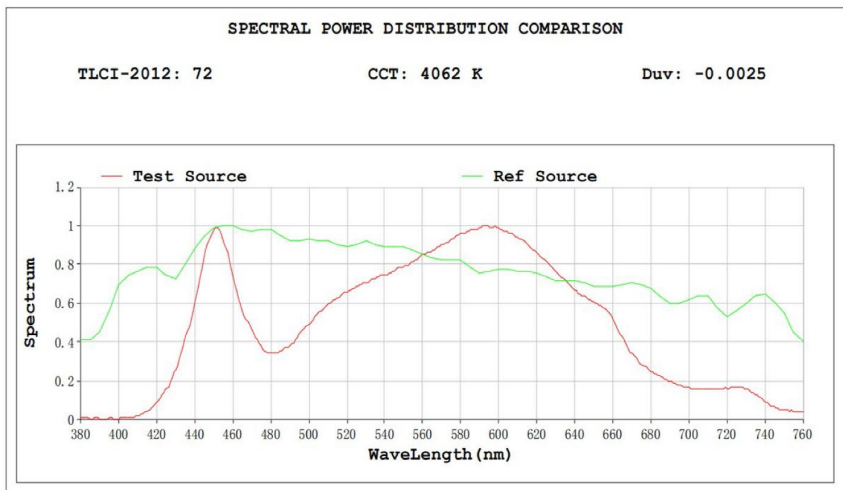
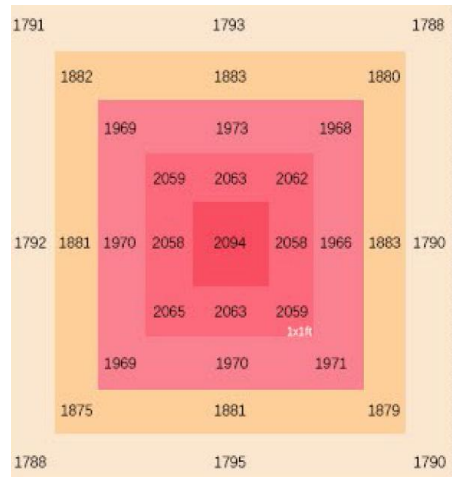
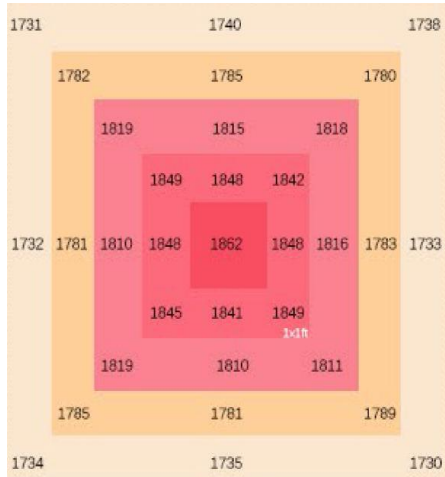
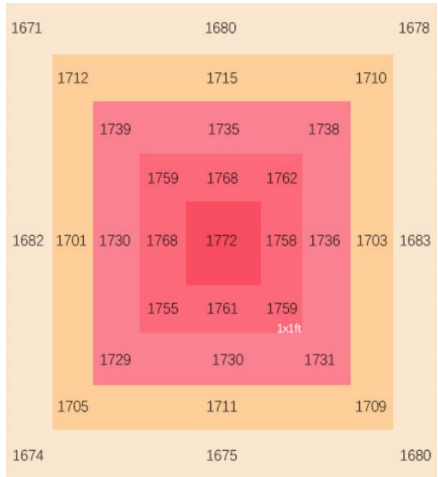
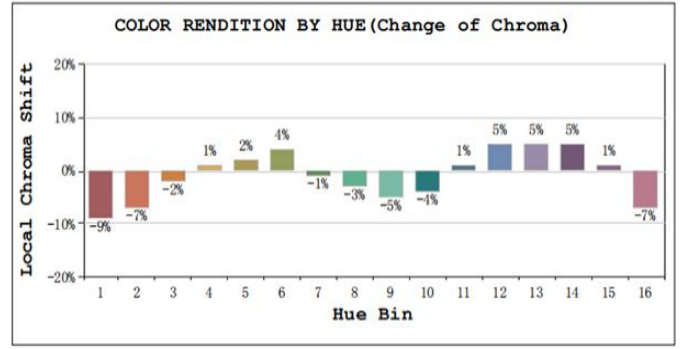
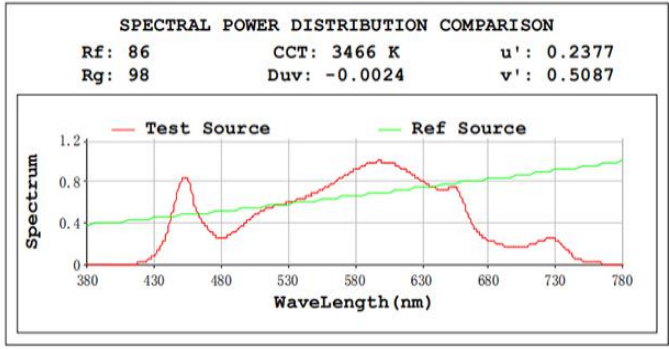
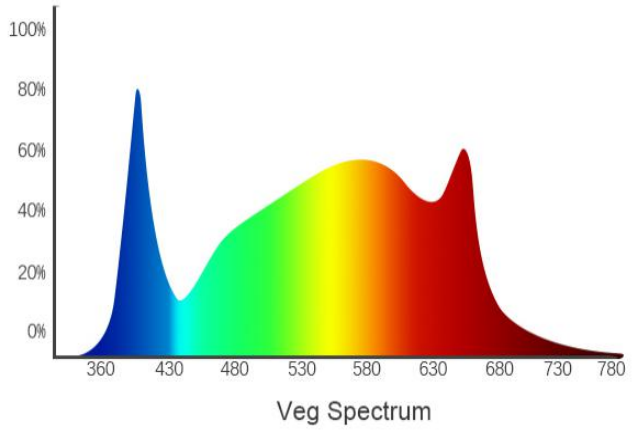
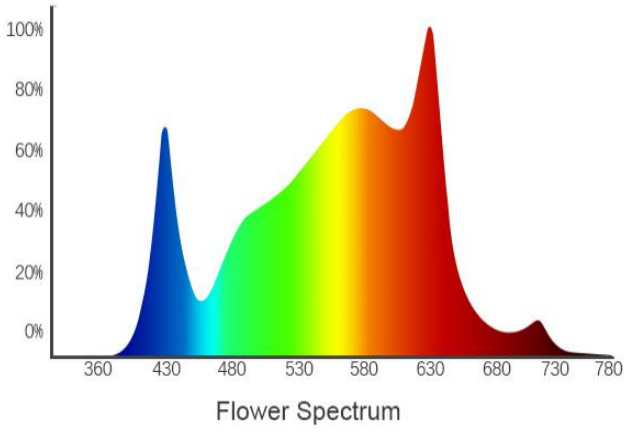

## Applications

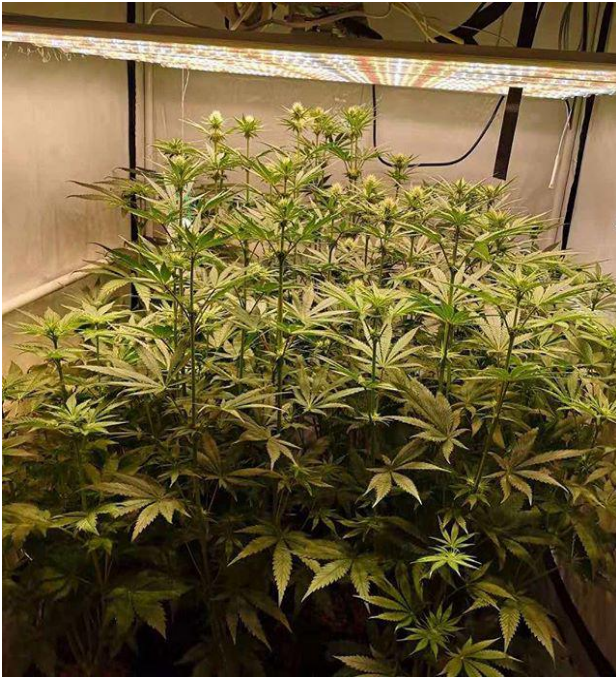

USA, Michigan, 12000 Square Meter, 1259 pcs light



Canada, Montréal, 3000 Square Meter, 429 pcs lights



UK, London, 6000 Square Meter, 665 pcs Lights



New Zealand, Wellington, 5000 Square Meter, 880 pcs light