

Classical Standard LED Wall Pack

Product Description

Eagle Star LED wall pack series of luminaires provides an architectural style with super bright, energy efficient LEDs. The low-profile, rugged die-cast aluminum construction along with a sealed and gasketed optical compartment make the light impervious to contaminants. It is ideal for wall/surface. Typical applications include building entrances, multi-use facilities, apartment buildings, institutions, schools, stairways and loading docks.



- Voltage 100-277V AV 50Hz/60Hz
- Light Efficiency 130lm/w
- Lifespan above 50,000 hours
- Qualified with CE, RoHS, cETL, ETL, DLC
- UL certificated LED driver
- 5 years warranty
- IP 65
- Heavy-duty cast aluminum housing is polyester powder coated to be rust and corrosion proof
- Sealed fixture is dirt and bug free
- Multiple knockouts for mounting convenience
- Photocell is available
- Die-casting aluminum alloy & PC
- Ambient temperature from -30°C to 50°C

Product Parameters

Input Power	40W	62W	80W	100W	120W
LED Chips	PHILIPS LEDS				
Initial Lumens	5,200lm	8,060lm	10,400lm	13,000lm	15,600
Efficacy	130lm/w	130lm/w	130lm/w	130lm/w	130lm/w
CRI	> 75Ra				
CCT	5000k				
Beam Angle	110°*130°				
Input Voltage	100-277V AV 50/60Hz				
Working Temperature	-30°C Up to 50°C (-22°F up to 122°F)				
Certification	CE, RoHS, cETL, ETL, DLC				
Warranty	5 years				
Carton/Pieces	1	1	1	1	1
G.W	4.5kg	4.6kg	4.7kg	5.2kg	5.6kg
Carton Size	44*32*29CM	44*32*29CM	44*32*29CM	44*32*29CM	44*32*29CM

Goods are shipped from CA NY TX Warehouses in the USA. Email: info@eaglestarled.com.

<https://eaglestarled.com/collections/led-wall-pack-light>

Dimensions

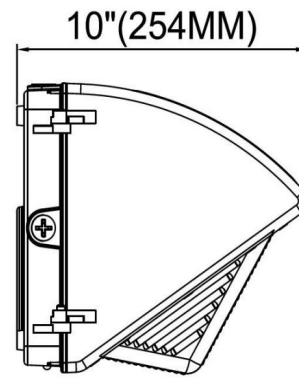
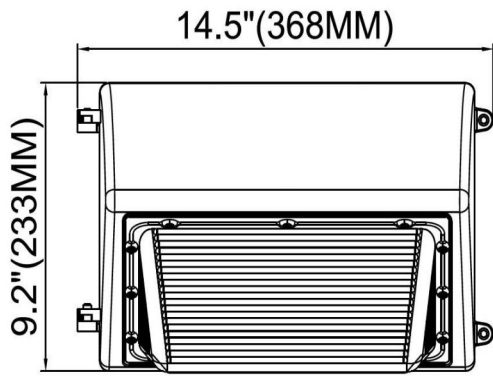

Photometrics

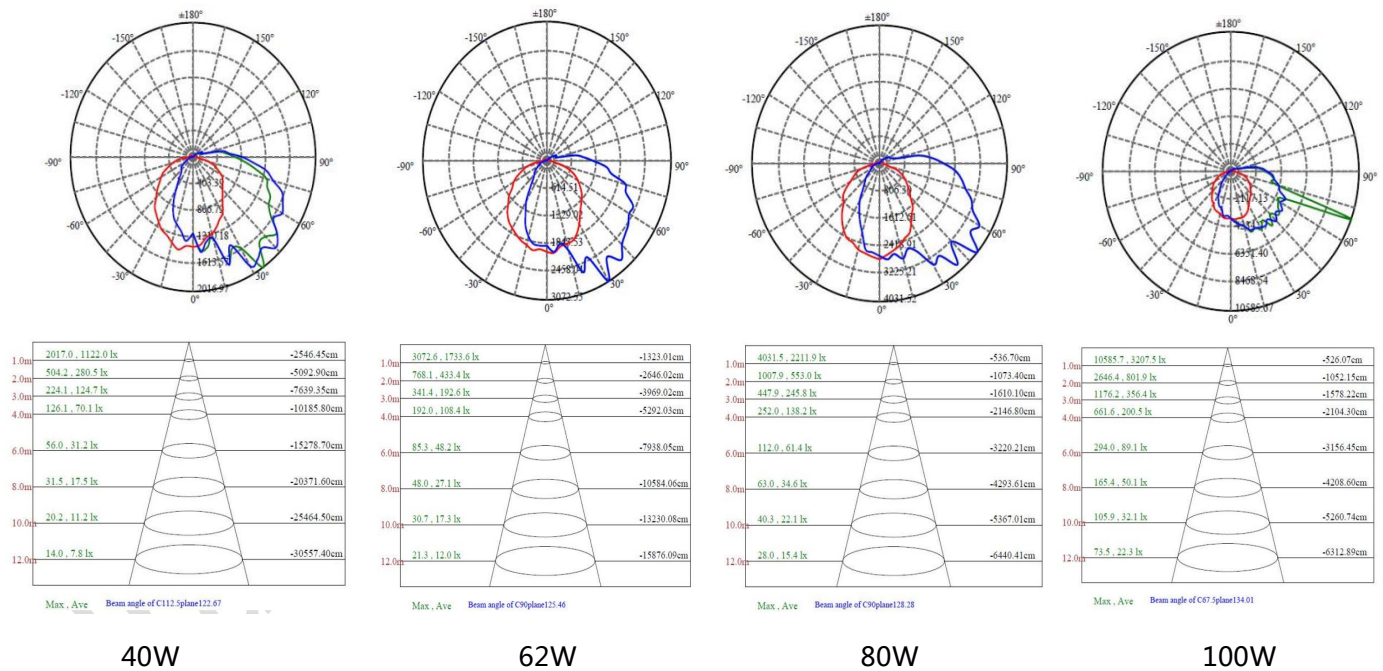

40W

62W

80W

100W

Installation



Get the screw on the fixture loosened by using the hexagon wrench, then take off the mounting plate on the fixture.

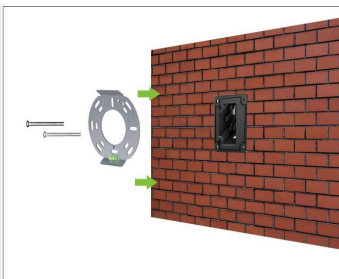

Use two #8 screws to attach the mounting plate to the junction box.



Use the threaded ermental to connect L/N/ ground wire, dim+/dim-(if not, please ignore) separately.



Complete the wiring to the power source and ground.

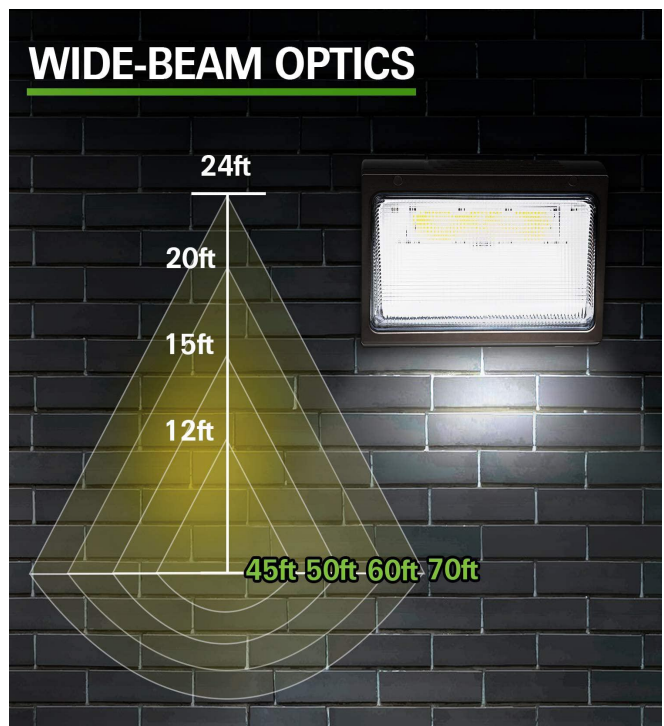

Goods are shipped from CA NY TX Warehouses in the USA. Email: info@eaglestarled.com.

<https://eaglestarled.com/collections/led-wall-pack-light>