

New Combo Heat Press Machine

Swing-away, Digital, Double-display, Self-locking

Instruction

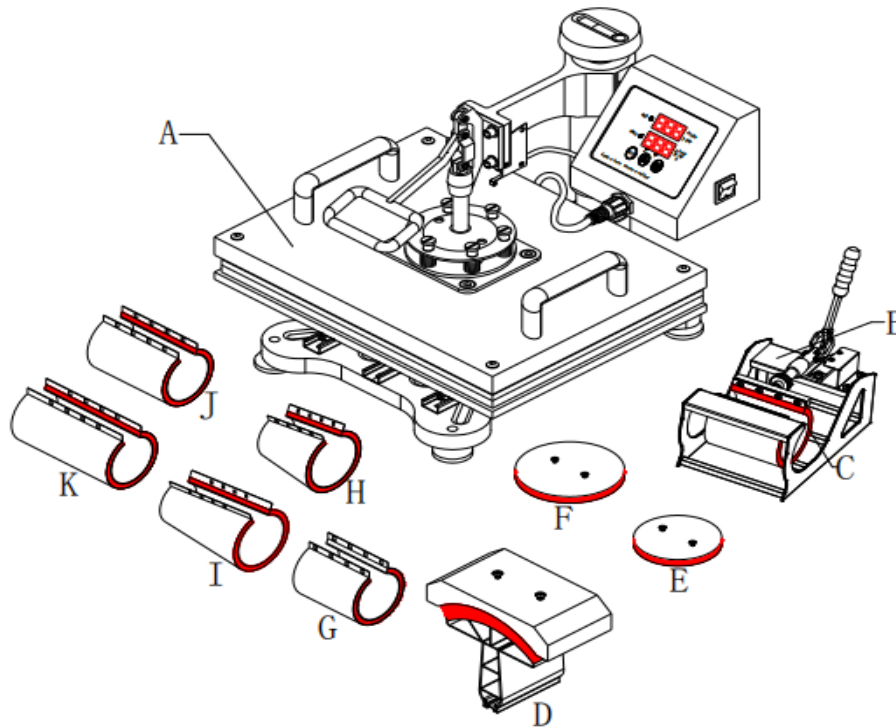

A: Platen Press (telfon-coated)

B: Mug Press Machine

C: Mug Press 11oz (4.7" × 9.25")

D: Hat/Cap press 5.5" × 3" (14 × 8cm) curved

E: Plate Press #1 - 5" max diameter (Ø12.5cm)

F: Plate Press #2 - 6" max diameter (Ø15.5cm)

G: Mug Press 9oz (4.7" × 7.5")

H: Mug Press 12oz (Cone)

I: Mug Press 17oz (Cone)

J: Mug Press 15 × 19cm (6" × 7.5")

K: Mug Press 13.5 × 23.5cm (5.3" × 9.25")

Respectable users, thanks for purchasing Yifei multi-functional heat press machine. It is the unique combo heat press with perfect slideway in the world, which have got the patented technology protection.

This machine adopts microprocessor program control, featuring high precision inparameter memory and control and unique touch button control panel in China. The advanced design philosophy and independent control unit structure provides convenience for combination and upgrading of machines and after-sale service.

With slideway, it is faster and more convenient to replace thermal transfer components. In addition, the design of the machine is very nice and luxurious, and machine takes very small room, so it is good for the selling and operating of the shops.

I . Features

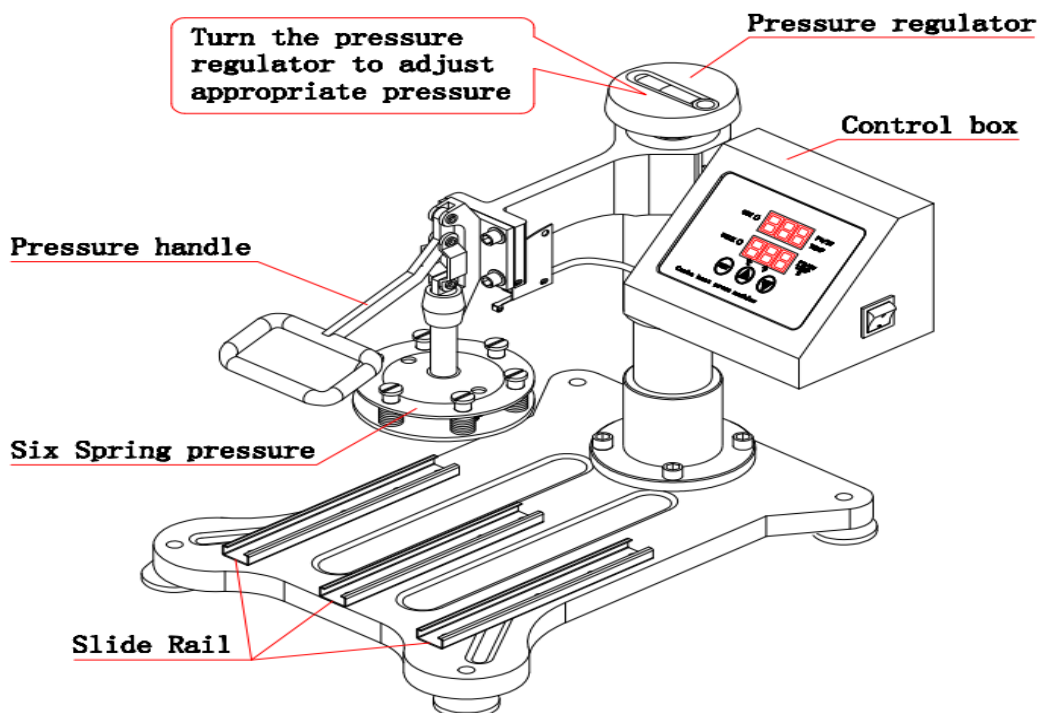

1. Brand new slideway design, so it is easy and fast to replace parts.
2. Add automatic count down button and self-clocking alarm.
3. Digital double control the controller uses microprocessor program, parameter memory, so the control accuracy is much higher.

4. For the controlling heating chip, it uses the new degree Celsius, so the power is more stable, and the circuit board will not break down when the voltage is not steady.

5. Heating thermocouple: adopting new generation “K” updated version heating thermocouple .with double lines merged ,it is safer and not easily broken down.(The glass tube is adopted for traditional ordinary machinery to pack thermistor .once in case of unstable voltage, it will be easily broken down ,burn out or crashed into pieces due to the uneven pressure!)

6. The aluminum plates are all upgraded and thickened, the quality becomes more secure and the phenomena of uneven base board and carrying capacity are avoided. The upgrading of quality, material and technology further guarantees the quality!

7. Can be lifted, lowered and rotated by 360 degrees and convenient to retrieve articles and transfer of alien articles.

8. Adding one heat-resisting foaming silicon on the baseboard, which can stand 400 centigrade degrees and will not deform.

II. Technical parameters

Specification:

Main Heating plate size: 15" × 15" (38 × 38CM)

Power: 1100W

Voltage: 110v, 60Hz, 10A

Temperature range: 0 - 250°C (0 - 482°F)

Timer control: 0 - 999 seconds

Packing Size: 23.4" × 20.3" × 17.5" (59.5 × 51.5 × 44.5CM)

4in1

Four Elements:

Main Heating plate (teflon-coated)

Hat/Cap pad: 5.5" × 3" (14 × 8cm)

Mug Press: 11oz (4.7" × 9.25")

Plate Press #1 - 5" (Ø12.5cm)

5in1

Five Elements:

Main Heating plate (teflon-coated)

Hat/Cap pad: 5.5" × 3" (14 × 8cm)

Mug Press: 11oz (4.7" × 9.25")

Plate Press #1 - 5" (Ø12.5cm)

Plate Press #2 - 6" (Ø15.5cm)

6in1

Six elements:

Main Heating plate (teflon-coated)

Hat/Cap pad: 5.5" × 3" (14 × 8cm)

Plate Press #1 - 5" (Ø12.5cm)

Plate Press #2 - 6" (Ø15.5cm)

Mug Press: 11oz (4.7" × 9.25")

Mug Press: 9oz (4.7" × 7.5")

8in1

Eight elements:

Main Heating plate (teflon-coated)

Hat/Cap pad: 5.5" × 3" (14 × 8cm)

Plate Press #1 - 5" (Ø12.5cm)

Plate Press #2 - 6" (Ø15.5cm)

Mug Press: 11oz (4.7" × 9.25")

Mug Press: 9oz (4.7" × 7.5")

Mug Press 12OZ

Mug Press 17OZ

10in1

Ten Elements:

Main Heating plate (teflon-coated)

Plate Press #1 - 5" (Ø12.5cm)

Mug Press: 9oz (4.7" × 7.5")

Mug Press: 12OZ

Mug Press: 6" × 7.5" (15 × 19cm)

Hat/Cap pad: 5.5" × 3" (14 × 8cm)

Plate Press #2 - 6" (Ø15.5cm)

Mug Press: 11oz (4.7" × 9.25")

Mug Press: 17OZ

Mug Press: 5.3" × 9.25" (13.5 × 23.5cm)

III. Operation guide

1. Connection

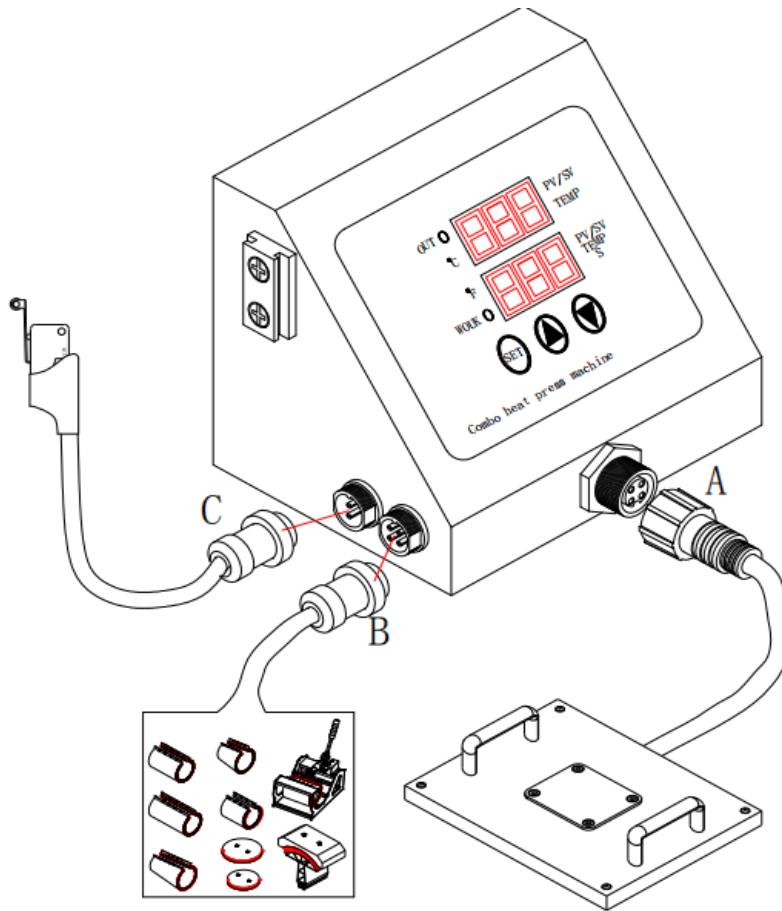

Connection Method for Each Part of the Heat Press Machine and the Control Box
As shown as image:

"A", "B" and "C" are respectively responsible for different functions.

"A" is the high-power plug for the heating plate of the main engine.

"B" is the plug for printing cups, plates and hats.

"C" is the plug for timer switch.

Due to different specifications and shapes, these three socket heat and socket aperture don't cross each other. Each set of socket heat and socket aperture has a directional or sequential guidance groove. Please align the orientation groove when plugging it, as shown in the red dotted line below:

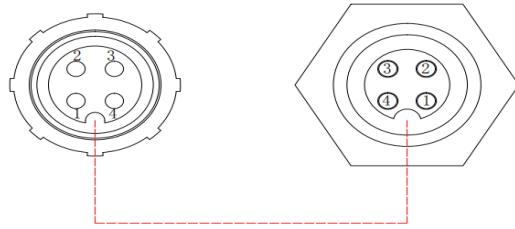

The red dashed line indicates that the bumps and grooves are properly connected. Since the four wires on the plug carry different functions, they must be connected in the correct way. The force in

the other direction can't be inserted by 50 kg after testing, but it can be easily done if some shapes are slightly deformed.

Also need pay attention to is that when you use the hot plate, "A" and "B" cannot be used at the same time, at the same time use will lead to connect to the "B" on the part after rising to the setting temperature and hot plate temperature cannot reach the set temperature, resulting in the hot plate can't be used normally. When "A" is connected to the control box, "B" must be unplugged. When "B" is connected to the control box, "A" must be unplugged.

2. Controller introduction:

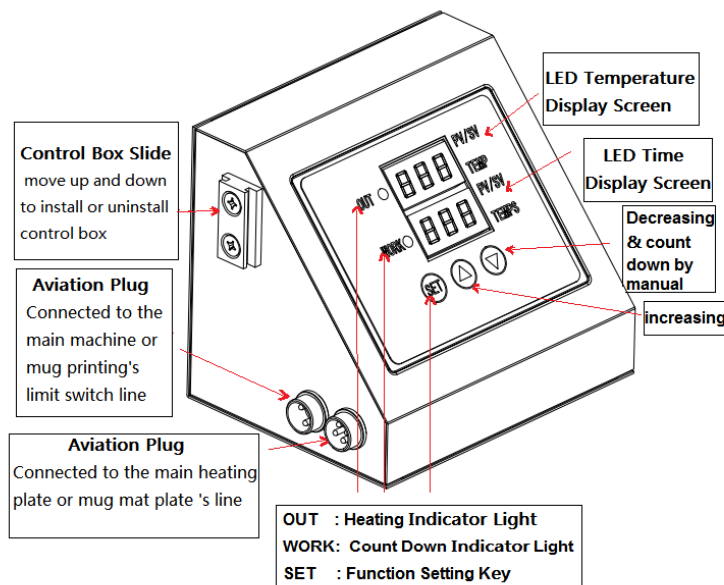

OUT: heating

WORK: count down introduction light

SET: function setting

▲: increasing

▼: decreasing /count down by manual

PV/SV
TEMP

 : LED temperature display

3. Parameter setting guide (Celsius showing):

Temperature or Time setting

Press "SET", the upper display will show "SP", and the lower of display will showing the temperature of last setting, then enter temperature setting option, press ▲ or ▼ (increase or decrease) to set the needed temperature. After setting well, Press "SET" again, LED will show "St", then enter the time setting, press ▲ or ▼ (increase or decrease) to set the needed time. (Normally the time is 180 seconds for mugs and 15-20 seconds for T-shirt printing)

4. Advanced parameters setting:

Long press "SET " button for 5 seconds, and then enter into advanced setting (Attention !!! Please don't use this advanced setting if you are not professional, In the course of using, the " E " displayed on the display screen is "t")

Warm Tip: Because of the use of high-temperature silica gel pad with bubbles, when used for the first time, the air inside the silica gel will expand and emit odor after heating. Please ensure indoor air circulation. Ten minutes later, the odor will disappear and there will be no odor in the future.

A、 Celsius and Fahrenheit setting

Long Press "SET" again, the controller display will showing C-F, the bottom of display will showing "C" or "F", please press ▲ or ▼ to adjust C (Celsius) or F (Fahrenheit) according to your demands.

B、 Temperature adjust: long press "SET" button for 5 seconds, and press "SET " one more time, the upper of display will showing "SC", then enter into temperature adjust, press ▲ to decrease, or press ▼ to increase the temperature.

When the actual platen measurement temperature not in accordance with the display temperature, please set again as following:

Press ▲ to decrease the temperature when the actual measurement temperature is lower the display temperature.

Press ▼ to increase the temperature when the actual measurement temperature is higher the display temperature.

C、 Overshoot setting:

Long press “SET” button for 5 seconds and press “SET” 2 times again, the upper display will show “P” and the bottom of display show “1”.

Press ▲ or ▼ to adjust. When turn on the machine, the temperature will raise up and over the setting temperature, and calm down to the set temperature, press ▲ button to increase “1”, when turn on the machine the temperature is raising very slow and cannot reach on the set temperature, press ▼ button to decrease “1”. The specific data of increase or decrease will be going well after several trying.

D、 Constant temperature setting: long press “SET” for 5 seconds, and press “SET” 3 times again, the upper display will showing “1”, the bottom of display showing “25”, press ▲ or ▼ to adjust. When power on the machine, the temperature raising up and reached the setting temperature, but the display showing not accurate, always higher or lower the actual temperature, please use this function to adjust. When the display showing temperature is higher the actual temperature, press ▲ button to adjust “25” become higher; when the display showing temperature is lower the setting, press ▼ to adjust “25” become smaller, until the display showing correctly.

E、 Heating period: long press “SET” button for 5 seconds, and press “SET”4 times again, the upper display will showing “t“, and the bottom display will shoeing “8”, press ▲ or ▼ to adjust.

The principle of this function is that when the temperature raising up and reached the setting temperature, the temperature controller will control the relay (SSR), every 8 seconds will power on and then power off after 8 seconds in order to control the constant temperature heating. If the platen heating up and reached the temperature, and the temperature not stable, always higher and lower, it says 8 seconds frequency is too low, press ▼ to adjust till it stable. If the temperature is stable, please do not use this function. since if use too much, will short the life of relay.

IV.Replacement of accessories

The counterdie of the heat press equipment is slide rail design. It is only necessary to plug it out and replace accessories easily and conveniently.

1. Adjustable mat

For uneven work surface, adjust the height and direction of the mat will be ok.

A、 Adjust the height of the mat roughly, in order to achieve the basic flat.

B、 Adjust the direction of the mat finely, in order to achieve the completely flat.

installation for each heating accessories :



Step 1, Loosen the screw with a screwdriver.
Step 2, Hold the handle and gently pull it forward, and then remove the parts

Platen press (for t-shirt): plug out other heating pad and put this flat into the sliding rails and fix it.

Plate press parts installation: maintain the bottom flat-panel, and push "E" or "F" (Plate Press) into the hole and fixed with a screwdriver.

Mug press parts installation: put foaming rubber pad fixed in mag shelves (push the long screws into the both side holes of the steel mug shelves directly, without disassembly of the screws). Mug press parts installation: the mug press you ordered (C、 G、 H、 I、 J or K) fixed on the Mug press machine "B", the cup pad (directly to the cup mat sheet steel on both sides of the long screw on both ends of the Mug press machine "B" directly into the corresponding hole location can, without the mounting screws), put the mug press mat thermocouple plug and mug press machine countdown on switch plug to control box outlet can printing the corresponding size mugs.

Cap press parts installation: push one part along the slide rails and push the other part into the hole and fixed with a screwdriver. Push the below part of the "D" (Hat/Cap press) along the slide rails, the above part (Hat/Cap pad printing mat) into the hole and fixed with a screwdriver.

C、 Adjust pressure

Adjust the right pressure before printing or after rep; ace different accessories.

Turn the pressure regulator to adjust appropriate pressure, then turn the back side to lock the screw cap.

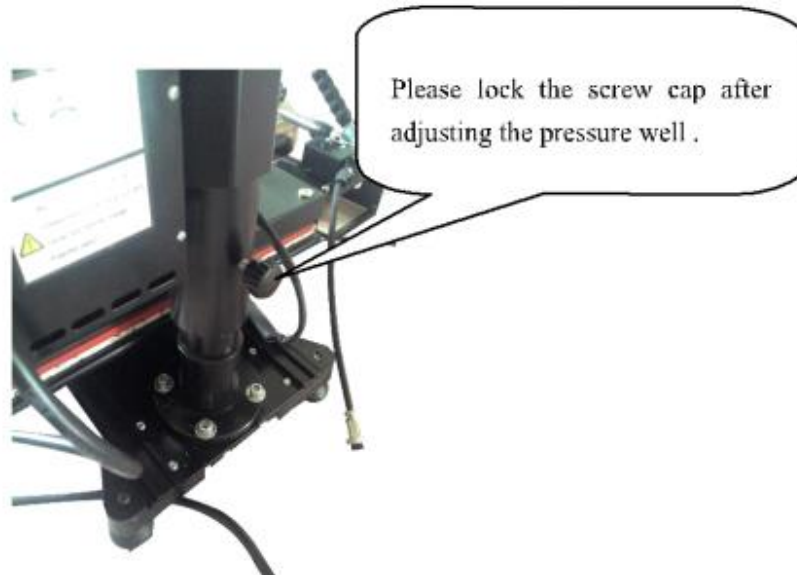

D、 Install control box to heating plate and connecting limit switch.

V. Kindly prompts:

To print and make individualized DIY products, it is also necessary for you to prepare the following equipment and materials.

1. Ink jet printer / six colors printer (For example: Epson R-230 / R270 / R290 / T50)
2. CISS (Continuous ink supply system)

Different models of Ink jet Printer will need different CISS

3. Sublimation ink / Heat transfer ink
4. High-temperature resistant tape
5. Sublimation paper / Heat transfer paper (for Ceramic and fabric)
6. Paper cutter
7. Press mug / cup and plate: Normal mug and plate will can't use for press, only sublimation mug and plate can be use.

Temperature and time requirements of different materials.

Material	Temperature	Time
Pure cotton	356°F-428°F (180°C-220°C)	15s-25s
Polyester	356°F (180°C)	40s
Chemical fiber	302°F-356°F (150°C-180°C)	10s-40s
Pearl board	356°F (180°C)	60s-100s
Metal pendant	356°F (180°C)	60s
Mouse pad	374°F (190°C)	50s
Vitrolite	392°F (200°C)	180s
Key ring pendant	356°F (180°C)	100s
Ceramics	356°F-428°F (180°C-220°C)	180s

VI. Warranty & Service

All machine can enjoy three months free warranty since the sale date. Please contact us, if have any quality problems.

More than warranty period we still provide long-term technical support and maintenance instruction, only charge the accessories costs.