



# MULTIFUNCTIONAL BLENDER

## USER MANUAL

[WWW.KOIOSSHOP.COM](http://WWW.KOIOSSHOP.COM)

# CUSTOMER SERVICE

Our customer service team is always ready to assist you if you have any issues or concerns.

 [www.koiosshop.com](http://www.koiosshop.com)

 [support@koiosshop.com](mailto:support@koiosshop.com)

 1-855-888-2111

 [m.me/KoiosShop](https://m.me/KoiosShop)

IMPORTANT SAFEGUARDS ..... 01

PRODUCT OVERVIEW ..... 03

USER GUIDE ..... 04

TROUBLESHOOTING ..... 05

CLEANING AND MAINTENANCE ..... 06

## 01 IMPORTANT SAFEGUARDS

To avoid electric shock, fire, or injury, please read the user manual carefully before using the appliance and keep it for future reference.

1. This appliance can be used by children aged from 8 years and above and persons.
2. Do not operate any appliance with damaged cord or plug, or after appliance has been dropped or damaged in any way. Contact KOIOS official for replacement.
3. Never immerse the motor unit or supply cord in water nor rinse it under the tap.
4. Make sure motor has completely stopped before removing cover.
5. Make sure the cover is securely locked into position before operating.
6. Unauthorized use or the use of attachments that do not belong to this product may cause fire, electrical shock or personal injury, or damage to your appliance.
7. This appliance is intended for home use only.

## IMPORTANT SAFEGUARDS 02

8. If the supply cord is damaged, it must be replaced by the manufacturer, its service agent or similarly qualified persons in order to avoid a hazard.
9. Always unplug the appliance from the outlet when it is not in use, before putting on or taking off parts, before removing food, and before cleaning.
10. Take care while handling the sharp cutting blades or emptying the bowl in order to avoid injury.
11. This product is strictly prohibited for no-load or overload operating.
12. Keep hands and utensils out of container while blending to reduce the risk of severe injury to persons or damage to the blender.
13. To reduce the risk of injury, never place cutter-assembly blades on base without jar properly attached.

## 03 PRODUCT OVERVIEW

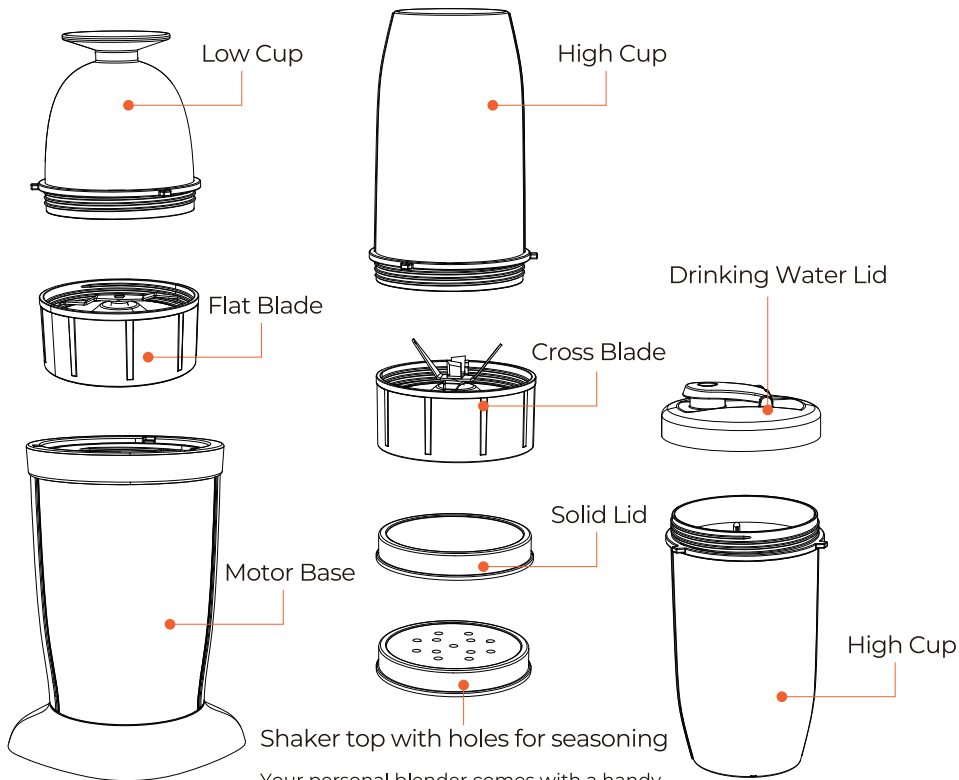

Your personal blender comes with a handy sieve lid that is used as a cooking shaker for pouring out spices such as cinnamon, nutmeg, ground coffee beans, cocoa powder, etc.

Food	Blade Type	Cup Type	Time
Fruits and Vegetables	Cross Blade	High Cup	60 seconds with the recommended max 400g loaded capacity with water
Coffee beans or nut	Flat Blade	Short Cup	30 seconds with the recommended max 100g loaded capacity

1. Place the cup on a flat surface with the open end facing up. Fill the cup with your favorite ingredients. Make sure not to exceed the maximum mark of the cup.
2. Twist the blade assembly onto the cup. Flip-over the cup and place it onto the motor base aligning the protrusion on the blade assembly with the groove on the inside surface of the motor base. Press the cup down to start blending.
3. Release the cup from the motor base. Remove the blade assembly.

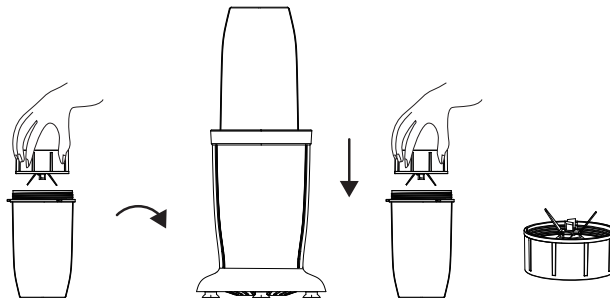

## 05 TROUBLESHOOTING

### **1. The appliance doesn't work.**

- 1). Check if the power cord is plugged into the outlet properly.
- 2). If it still does not work, please contact us and we will provide 24-month replacement or return service.

### **2. Can I blend hot foods?**

No. NEVER blend hot foods in a blender. Cool the food to a temperature that is lower than 60°C (140°F).

### **3. My KOIOS blender smells when I use it.**

It is normal for a new product to produce an unusual smell when it is used for the first time. It stops after you have used the appliance several times. If an unusual smell appears after the usage for a long time, turn the appliance off and let it cool down for 60 minutes.

### **4. Blender stops while blending.**

Unplug the power cord, take out the cup and try to:

- a.Shake the cup;
- b.Reduce the loaded capacity.

### **5. How to crush ice cubes?**

1. Don't put too many ice cubes at a time to prevent the blade from jamming.
2. Don't blend continuously for more than 20 seconds.
3. It is recommended to press down the cup intermittently several times in quick, two-second bursts until the ice cubes are crushed completely.
4. Please add enough liquid (more than one third).



## CLEANING AND MAINTENANCE 06

1. Remove the cross/flat blade attachment from the cross blade plastic base by pushing the blade gear.
2. Remove the gasket ring.
3. Add dishwashing liquid. Clean the gasket ring and the cross blade attachment with the small brush to loosen debris, then rinse with water.
4. Dry well in a cool place.
5. Assemble the extractor blade. Please ensure the gasket ring attached properly.

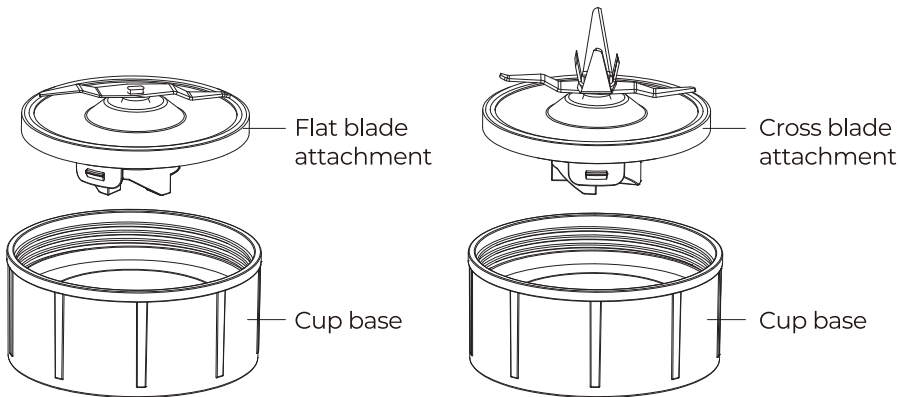

## 07 CLEANING AND MAINTENANCE

1. UNPLUG the appliance from the power source when it is not in use.
2. Please store the appliance in a dry, well-ventilated place when it is not in use for a long time.
3. You can clean the accessories under running water.
4. Clean the blender with a dry cloth. To protect against the risk of electrical shock, never immerse the motor base in water or place it under running water.

### DISPOSAL

The appliance should not be disposed off via the household bin collection. Disposal of the appliance should be carried out in accordance with the national regulations. If electrical appliances are disposed of in landfills or dumps, hazardous substances can leak into the groundwater and get into the food chain, damaging your health and well-being.

When replacing old appliances with new ones, the retailer is legally obligated to take back your old appliance for disposal.





# KOIOS

-  [www.koiosshop.com](http://www.koiosshop.com)
-  [support@koiosshop.com](mailto:support@koiosshop.com)
-  1-855-888-2111
-  [m.me/KoiosShop](https://m.me/KoiosShop)



Made in China