

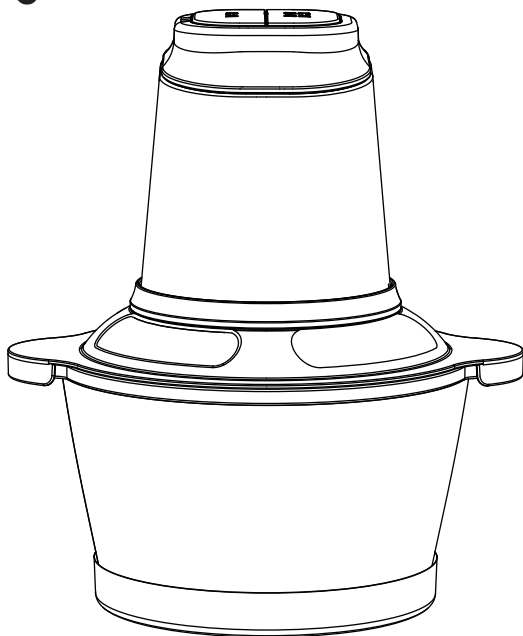

KOIOS



FOOD PROCESSOR

USER MANUAL

WWW.KOIOSSHOP.COM

CUSTOMER SERVICE

Our customer service team is standing by to assist you if you have any questions or concerns.



www.koiosshop.com



support@koiosshop.com



1-855-888-2111



m.me/KoiosShop

CONTENTS

Important Safeguards	01
Special Cord Set Instructions	03
Package Contents	03
Product Introduction	04
Before Using Your Food Processor	05
How to Use Your Food Processor	06
Tips for Using Your Food Processor	08
Cleaning and Maintenance	09
Troubleshooting	10

IMPORTANT SAFEGUARDS

WHEN USING ELECTRICAL APPLIANCES, BASIC SAFETY PRECAUTIONS SHOULD ALWAYS BE FOLLOWED, INCLUDING THE FOLLOWING:

Your safety and the safety of others are very important.

We have provided many important safety messages in this manual and on your appliance. Always read and obey all safety messages.



This is the safety alert symbol.

This symbol alerts you to potential hazards that can kill or hurt you and

others. All safety messages will follow the safety alert symbol and either

the word "DANGER" or "WARNING". These mean:



You can be killed or seriously injured if you don't immediately follow instructions.



You can be killed or seriously injured if you don't follow instructions.

All safety messages will tell you what the potential hazard is, tell you how to reduce the chance of injury, and tell you what can happen if the instructions are not followed.

WARNING

1. Ensure the polarized plug fit into the polarized outlet only one way. If not, reverse the plug or contact a qualified electrician to install the proper outlet. **DO NOT** modify the plug in any way.
2. Never use the extension cord with this product.
3. Remove utensils prior to processing to avoid the damage of the jar or personal injury.
4. The Chopping Blade Assembly is sharp and unlocked in place. Remove and hold it by the shaft before emptying contents to prevent the risk of laceration.
5. Don't blend hot liquids to avoid excessive pressure to prevent risk of being burned.

CAUTION

6. Don't allow young children to operate or use it as a toy. Close supervision is necessary when any appliance is used near children.
7. Keep the appliance and the power cord away liquids.
8. Don't let the power cord hang over the edge of table or counter or touch hot surfaces such as the stove.
9. Don't operate the appliance with a damaged cord or plug to ensure the device functions properly.
10. Remove the power cord from the electrical outlet when not in use.
11. Just grasp the plug to pull the power cord from electrical outlet for disconnection instead of yanking it.
12. Keep the appliance away from any hot surfaces.
13. Don't use the appliance's accessories in the microwave.
14. Don't remove the power pod before the chopping blade assembly has stopped turning.
15. Don't sharpen the blades.
16. Don't use the cracked container.
17. Don't add overmuch food into the appliance.
18. Don't use the appliance if the chopping blades are bent or damaged.
19. Keep everything away from working blades and container to prevent personal injury and damage to the appliance.
20. Never operate the appliance without the lid and bowl in place.
21. Don't try to defeat the interlock mechanism. Make sure that the cutting blades are properly assembled before operating the appliance.
22. This product is only for household use.
23. Don't operate the appliance continuously for more than 15 seconds.
24. Don't operate the appliance without anything.
25. If the appliance overheats, a thermal switch will become activated to shut off the motor. Unplug the appliance and let it cool down for about 20 minutes before using it again.
26. Ensure the cover is secured in place before operating the appliance.

SPECIAL CORD SET INSTRUCTIONS

The length of the cord used on this appliance was selected to reduce the hazards of becoming tangled in or tripping over a longer cord. If a longer cord is necessary, an approved extension cord may be used.

The electrical rating of the extension cord must be equal to or greater than the rating of the appliance. Care must be taken to arrange the extension cord so that it will not drape over the countertop or tabletop where it can be pulled on by children or accidentally tripped over.

This appliance has a polarized plug (one blade is wider than the other). As a safety feature, this plug will fit in a polarized outlet only one way.

If the plug does not fit fully in the outlet, reverse the plug. If it still does not fit, contact a qualified electrician. Do not attempt to fix it on your own.

SAVE THIS INSTRUCTIONS

PACKAGE CONTENTS

- 1 * Power Pod
- 2 * Chopping Blade Assembly
- 2 * Lid
- 8 * Blade Protector
- 2 * Sealing Ring
- 2 * Non-slip Base
- 1 * Glass Processing Bowl
- 1 * Stainless steel Processing Bowl
- 1 * User Manual

PRODUCT INTRODUCTION

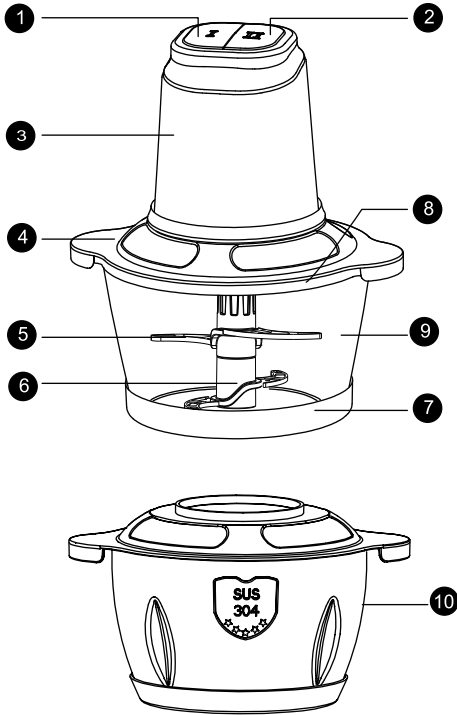

- 1. Low Speed Button
- 2. High Speed Button
- 3. Power Pod
- 4. Lid
- 5. Blade Protector

- 6. Chopping Blade Assembly
- 7. Non-slip Base
- 8. Sealing Ring
- 9. Glass Processing Bowl
- 10. Stainless steel Processing Bowl

BEFORE USING YOUR FOOD PROCESSOR

Before first use of the Food Processor, we recommend washing the unit. Please refer to cleaning instructions in the Cleaning & Maintenance section on page 9.

※ Remove and then install the chopping blade assembly again.

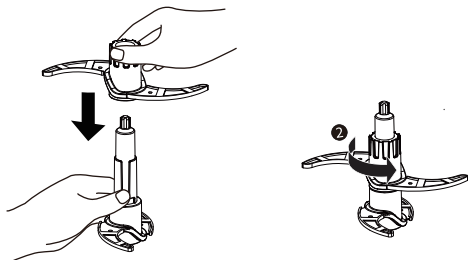

1. Firstly install the upper blade holder into the lower blade holder, and then tighten them by turning them counterclockwise.



⚠ WARNING

Cut Hazard.
Handle blades carefully.
Failure to do so can result in cuts.

2. Carefully remove the blade protector and avoid being hurt by the sharp blades.

HOW TO USE YOUR FOOD PROCESSOR

 **Review warning and caution statements on page 1 - 2 before proceeding.**

2. Pre-cut large and hard foods into 2.5cm cubes to make them fit into the processing bowl.

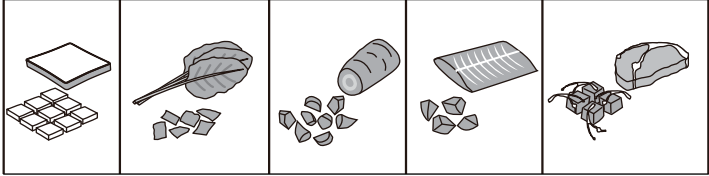

3. Insert the chopping blade assembly into the spindle pin inside the processing bowl.

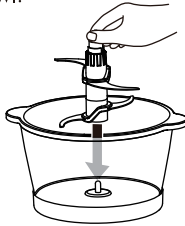

 **CAUTION: Never add ingredients into the container before placing the blade assembly into it.**

4. Put the pre-cut ingredients into the processing bowl and ensure they are below the MAX position. **DO NOT OVERFILL.**



 **CAUTION: Do not process flour, frozen fruit, or hard spices. This could damage the chopper.**

5. Install the lid on the processing bowl.



6. Install the power pod on the top of the lid. Rotate it if it cannot be successfully installed.



⚠ CAUTION: The power pod will only work if it is properly installed on the lid.

7. Plug the power cord into a power outlet and press the speed button to start the appliance.

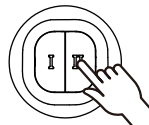
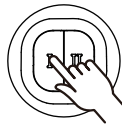

NOTE: Low speeds are good for softer ingredients and hard ingredients are good for high speeds.

8. Hold the processing bowl firmly while pressing the speed button to ensure the unit stays in place.

⚠ IMPORTANT: DO NOT operate the appliance continuously for more than 30 seconds at a time. For coarsely chopped foods, use repeated short pulsing action until the desired consistency is reached.

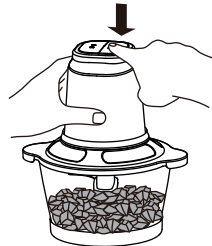

TIPS FOR USING YOUR FOOD PROCESSOR

- For mincing, chopping and pureeing, increase the length of pulses.
- For coarse chopping, use short, quick pulses and monitor food texture.
- Pre-cut large and hard foods into 2.5cm cubes to make them fit into the processing bowl.
- For raw ingredients: peel, core and or remove seeds and pits.
- For the finest chop, process continuously. Watch ingredients closely to achieve desired consistency and scrape the work bowl as necessary.
- For best results most foods should not reach more than 2/3 of the way up the work bowl.
- For pitted ingredients, the pitted ingredients must be removed before being chopped.

CLEANING AND MAINTENANCE

⚠ CAUTION: Make sure that the power pod is unplugged from power source before inserting or removing the blade assembly and before cleaning.

DO NOT immerse the power pod into water or any other liquid.

Clean with a damp sponge or cloth and wipe dry.

DO NOT place the lid in the dishwasher or it may damage the lid.

1 Separate/remove all parts from each other.

2 **Hand Washing:** Wash the Processing bowl, lid, and Chopping Blade Assembly in warm, soapy water. When washing the Chopping Blade Assembly, use a dish-washing utensil with a handle to avoid direct hand contact with blades.

Handle the Chopping Blade Assembly with care to avoid contact with sharp edges. Rinse and air dry thoroughly.

Dishwasher: Only Processing bowl and Chopping Blade Assembly are all dishwasher safe. Ensure that the Chopping Blade Assembly is removed from the container before placing in the dishwasher.

⚠ WARNING: Handle the chopping blade assembly with care when washing, as the blades are sharp. Contact with the blades' edges can result in laceration.

TROUBLESHOOTING

PROBLEMS	POSSIBLE REASONS & SOLUTIONS
Motor doesn't start or blade assembly doesn't rotate.	Check whether the bottom of power pod is clean and ensure no food blocks connection when placing it on the container.
	There is too much food in the container.
	The unit is overheated. Unplug and wait for about 20 minutes before using it again.
	Make sure the power pod is securely placed on the lid.
	Check whether the plug is securely inserted into the electrical outlet.
Food is unevenly chopped.	Maybe you've chopped too much food at one time, or the pieces are too big. Cut the food into smaller pieces. Chop smaller amounts per batch.
Food is chopped too fine or too watery.	The food has been over processed. Use brief pulses or process the food for a shorter time. Let the chopping blade assembly stops completely between pulses.



www.koiosshop.com



support@koiosshop.com



1-855-888-2111



m.me/KoiosShop