

Laminar Flow Cabinet

User Manual

(Apply to Vertical Flow Type BKCB-V1100/1300/1500)

Preface

Thank you for using the Laminar Flow Cabinet produced by our company. In order for you to use this product properly and to prevent damage to persons, property and experimental products, please be sure to read and comply with the contents of the manual carefully. If you do not use the cabinet in the way specified by the manufacturer and disassemble the cabinet by yourself, the protection provided by the cabinet lock may be damaged.

Only our after-sales service personnel and technicians authorized by us can install and repair this cabinet, otherwise it may cause electric shock or fire.

Be sure to place the cabinet firmly on a solid and horizontal surface. If the ground is not firm or the cabinet placed in an inappropriate place, it will cause the cabinet to fall over and cause injury to people.

Please use the AC 220V \pm 10% special power supply indicated on the nameplate of this cabinet, otherwise it may cause fire or electric shock. If the use of voltage does not meet the requirements of the marked power supply, you need to add 3000W or more automatic voltage regulator that suitable for motor load.

Please use a grounded power outlet to prevent electric shock. If the power outlet is not grounded, be sure to have a professional technician install the grounding wire.

This cabinet is for indoor use only, do not use it in the open air. If Laminar Flow Cabinet is wet by rain, it may cause leakage or electric shock.

Do not put the container with water on the Laminar Flow Cabinet. If the item falls, it may cause injury to people. And the run-off water can cause cabinet leakage or electric shock. Do not ground Laminar Flow Cabinet through gas pipes, power pipes, telephone lines or lightning rods. Such grounding may cause electric shock or other greater danger.

If the Laminar Flow Cabinet is not operating properly, stop using it and unplug it from the power source. Operating the cabinet in an abnormal condition may cause other hazards such as cabinet leakage.

When the Laminar Flow Cabinet is not used for a long time, unplug the power supply to prevent the power cord from causing electric shock, leakage and other dangers due to aging.

Do not store acid, alkali and other corrosive, flammable, explosive or volatile hazardous materials in the Laminar Flow Cabinet, or use combustible spray near the Laminar Flow Cabinet, which may easily cause cabinet damage as well as casualties and property damage.

If you need to move the cabinet after installation, you need to confirm with the manufacturer.

Dispose the replaced old filter as biological waste.

The top air outlet must not be blocked.

Our company reserves the right to change the design and user manual of the products, when changes, the user will not be notified.

Catalogue

Preface	1
Chapter 1 Product Introduction.....	3
1.1 Product Description	3
1.2 Product Features.....	3
1.2.1 Control of glass window	3
1.2.2 Structure.....	3
1.2.3 UV sterilization	3
1.3 Technical Parameters	4
1.4 Product Structure	4
Chapter 2 Installation.....	6
2.1 Installation Environment.....	6
2.2 Location Selection	6
2.3 Installation Steps.....	6
2.4 Check after Installation	9
Chapter 3 Operating Instruction.....	11
3.1 The Main Screen Introduction	11
3.2 Settings Interface	12
3.2.1 Timing switch.....	12
3.2.2 Standby settings	12
3.3 Introduction to the use process.....	12
Chapter 4 Maintenance	14
4.1 Comprehensive Maintenance Cycle.....	14
4.2 Maintenance Methods.....	14
4.2.1 Cleaning.....	14
4.2.2 Regular maintenance.....	14
Chapter 5 Handling of Common Problems.....	16
Chapter 6 Simple Parts Replacement.....	18
6.1 Replace the Fuse	18
6.2 Replace the UV Lamp.....	18
6.3 Replace the LED Lamp.....	19
Chapter 7 Caution	20
7.1 Storage Conditions.....	20
7.2 Transportation Conditions.....	20
7.3 Caution.....	20
Chapter 8 Label Description	22
Chapter 9 Warranty Commitment	23
Appendix Wiring Schematic Diagram	24

Chapter 1 Product Introduction

1.1 Product Description

There are strict requirements for the cleanliness of the air in the operating area including laboratories, electronic technology, aerospace, precision equipments and other fields at present. And clean air technology is also required in biological fields such as medicine and health, biopharmaceuticals, food, medical science experiments, sterile microorganisms, etc. Laminar Flow Cabinet is an ideal local air purification equipment to improve the clean working environment.

The cleanliness of the work area of this Laminar Flow Cabinet reaches ISO class 5, which can effectively improve the process conditions, ensure the accuracy of products and provide a sterile environment in the fields of scientific experiments and biological experiments.

1.2 Product Features

1.2.1 Control of glass window

The front glass window is counterweight controlled, it can be stopped smoothly at any height position within the range, so that the glass window can also be controlled to take out the test products or instruments in the operation area when the power is out.

1.2.2 Structure

- (1) The cabinet adopts 1.2mm thick cold-rolled steel plate and electrostatic spraying on the surface, which enhances the structural strength and makes the whole cabinet more stable and heavy.
- (2) The work surface is made of stainless steel, which is beautiful and corrosion-resistant.
- (3) The bracket is made of metal with electrostatic spraying on the surface.
- (4) Control panel adopt touch switch to make the cabinet appearance beautiful and easy to operate.

1.2.3 UV sterilization

This Laminar Flow Cabinet using UV-C type 254nm wavelength UV sterilization, which can not only kill the active cells of microorganisms, but also kill strong heat-resistant budding spores and other mold spores, in addition that phage and viruses can quickly break under UV rays.

1.3 Technical Parameters

Model	BKCB-V1100	BKCB-V1300	BKCB-V1500
Dimension(W*D*H)	1100*630*1860mm	1300*630*1860mm	1500*630*1860mm
Work area dimension (W*D*H)	1000*610*650mm	1200*610*650mm	1400*610*650mm
Air flow mode	Vertical Flow Type		
Work surface height	750mm	750mm	750mm
Front window	4.8mm		
HEPA	HEPA without partitions, with 99.995%, filtration efficiency for $\phi 0.3\mu\text{m}$ particles		
HEPA specification	910*400*69mm	1090*400*69mm	1310*400*69mm
Noise	$\leq 65\text{dB(A)}$		
Illumination	$\geq 300\text{ lx}$		
Vibration	$\leq 5\mu\text{m (rms)}$		
Temperature rise	$\leq 8^{\circ}\text{C}$		
Display	LCD (Liquid Crystal Display)		
Waterproof socket	The power of the cabinet used does not exceed 500W.		
Grounding resistance	$\leq 0.1\Omega$		
Power supply	AC220V $\pm 10\%$, 50 Hz(standard) AC110V $\pm 10\%$, 60Hz (Optional)		
Working area	304 Brushed stainless steel		
Cabinet	Made of 1.2mm (1mm) cold-rolled steel plate and the surface is electrostatically sprayed.		
UV Lamp appointed timing	UV lamp delayed 10s open for the safety of the operator.		
UV Lamp	15W	30W	40W
LED lamp	8W	8W	16W
Velocity of air flow	0.2-0.45m/s		
Safe height of front window opening	200mm	200mm	200mm
Max height of front window opening	350mm	350mm	350mm
Net Weight	190kg	225kg	235kg
Gross Weight	248kg	289kg	308kg
Alarm for height of front window opening	Yes		
Safety	Colonies numbers $\leq 0.5\text{CFU}/30\text{min}$		

1.4 Product Structure

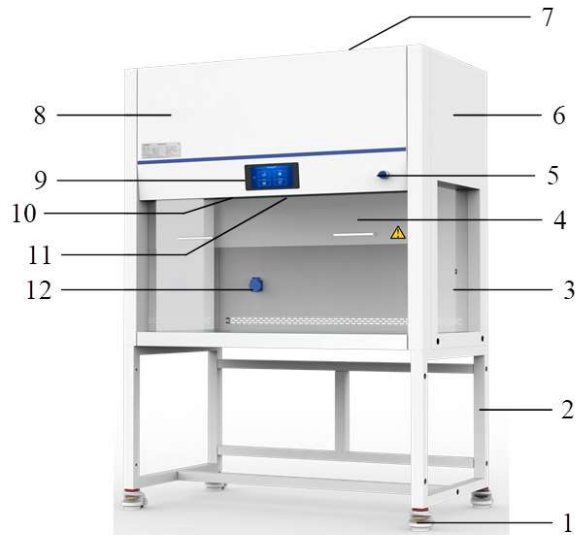

Figure 1 Product Structure

1	Footmaster caster	2	Base stand	3	Side window
4	Front window	5	Button switch	6	Upper cabinet
7	Power socket	8	Control panel	9	Touch screen
10	LED lamp	11	UV lamp	12	Waterproof socket



Caution

- The power of the cabinet used on the receptacle should not exceed 500W (rated voltage * rated current 220V * 2.3A).
- The waterproof receptacle as waterproof only when its front cover is lay down; the receptacle cannot be considered as waterproof when the front cover is opened.

Note: IP44 is the socket degree of protection. According to IEC 60529: Protected the inside of the socket against foreign solid objects of 1.0mmΦ and greater from contacting the internal parts; protected the socket against splashing water from all directions from causing damage.

Chapter 2 Installation



Caution

This Laminar Flow Cabinet needs to be installed by our trained and qualified engineers.

1. Remove all packaging components.
2. Inspect the external surface of the host for scratches, deformations or foreign objects.
3. Carefully inventory accessories and information according to the packing list in the manual.
4. Move the entire cabinet to a position as close as possible to the final location and easy to install.



Caution

When handling the Laminar Flow Cabinet, it is strictly forbidden to place or disassemble it upside down.

2.1 Installation Environment

- a. Indoor use.
- b. Humidity range: $\leq 80\%$.
- c. Power supply: AC 220V $\pm 10\%$ (standard) AC 110V $\pm 10\%$ (Optional).
- d. Transient overvoltage: Facility category (overvoltage category) II.
- e. Rated pollution level: Class 2.

2.2 Location Selection

Laminar Flow Cabinet should be installed in the clean laboratory or indoor away from the dust source and vibration source, not at the channel. If the laboratory has windows, it should always be in the closed state. Laminar Flow Cabinet should not be placed in the circulation air entrance, for fear that the air blow over the former operation area or blow to the HEPA.

If space allows, there should be 30cm space behind and around the cabinet for cleaning, if not, there should be minimum 8cm per side and 3.8cm space at the back for cleaning. The cabinet power outlet can be closed to facilitate the maintenance, and there is no need to move the cabinet to ensure electrical safety. Do not put the cabinet in the position where it is difficult to operate and disconnect the cabinet.

2.3 Installation Steps

- a. After moving to the designated indoor location, remove the packing material and check its hardware according to the packing list to make sure there is no damage during transportation.
- b. Assemble and place the base

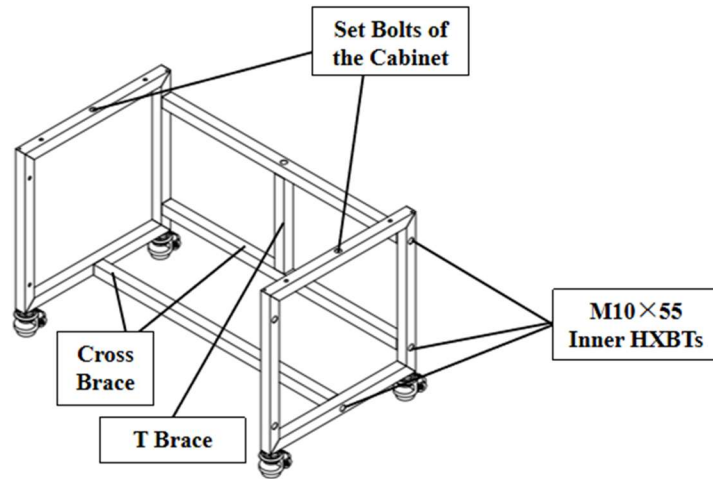

Figure 2 Base assembly

Screw out the M10×55 inner HXBTs in the cross brace and T brace, assemble the base tightly and firmly refer to the above figure.

c. Connect the host and base

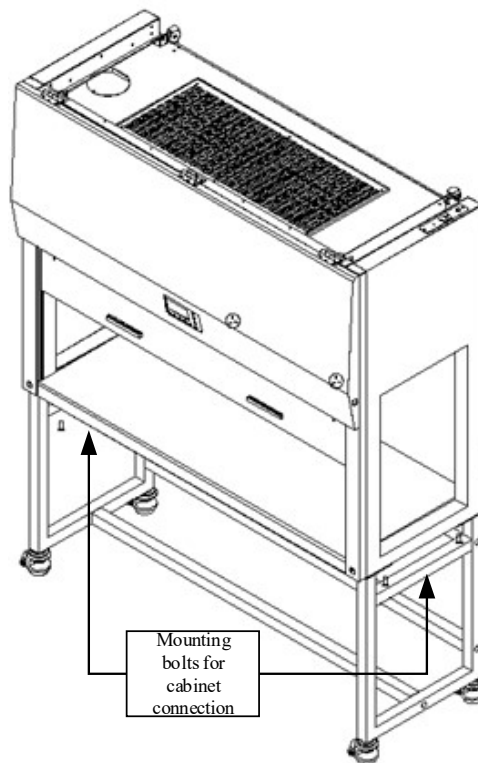

Figure 3 Connecting the host to the base

According to the above diagram, use M10×55 inner HXBTs, flat washers $\Phi 10$, spring washers $\Phi 10$ to fasten firmly through the bottom up to the base and side plate.

d. Unlock the front window

Before pushing or pulling the front window, you need to use a Phillips screwdriver to loosen the fixing screws on both sides of the counterweight plate on the back of the cabinet, so that the front window can be pushed or pulled smoothly, as shown in the figure below.

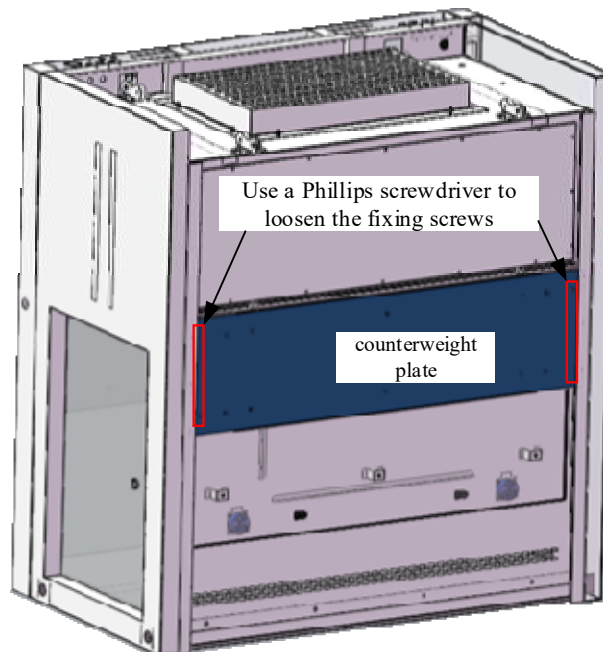

Figure 4 Unlock front window

e. Place the whole cabinet

The cabinet should be placed in a protected area of airflow to prevent the airflow from ventilation system, air conditioner, door, window and personnel movement from affecting its function.

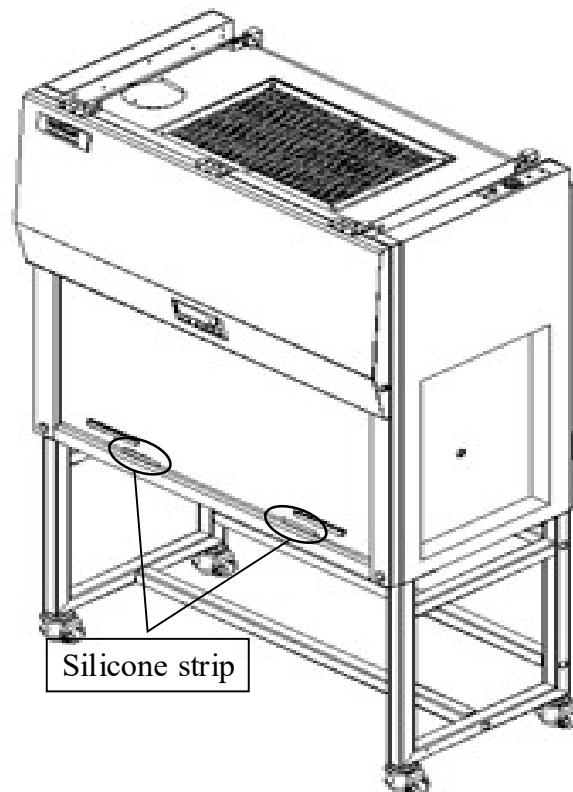

Figure 5 Diagram of silicone strip position



Caution

- The cabinet should be installed in a wide and spacious space.
- When moving the cabinet, it is necessary to cut off the power and adjust the casters before moving slowly.
- The function of the silicone strip is to prevent damage to the front window glass during transportation. Remove them after placing cabinet.

f. Footmaster caster adjustment

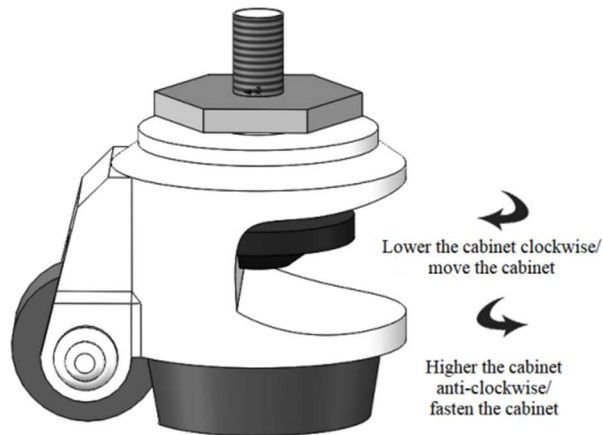

Figure 6 Footmaster caster

Rotate the red part of the caster clockwise, lower the corresponding base legs, lower the height of the cabinet, then lower four casters at the same time to move the cabinet position; counterclockwise rotate the red part of the caster, raise the corresponding base legs, raise the height of the cabinet, raise four casters at the same time to fix the cabinet; four casters can be adjusted at the same time to make the cabinet in the horizontal stable state.

2.4 Check after Installation

After powering up, check the following items according to the normal use process.

Test item	Normal condition
Normal power on-off	Connect the power supply and power on the cabinet.
Fan operation	Click the "Fan" button, fan works normally.
Front window up and down movement	The front window slides smoothly up and down.
LED lamp	Click "LED lamp" button, the LED lamp is on.
Waterproof socket	Click "Waterproof socket", output power is AC 220V±10%(standard) AC 110V±10%(Optional) tested by multimeter.

- This product is placed in laboratory sections or teaching laboratories.
- The installation location should be far away from dust and vibration sources.
- Be sure to plug the power supply into an outlet with a ground wire and ensure that the ground terminal is reliably grounded, and use a power supply with a leakage protection device.
- The interior and surroundings of the cabinet must be carefully cleaned after

installation using a vacuum cleaner or a tool that does not produce fibers.

- Test the average velocity of working area with an anemometer after installation and cleaning. When the average airflow velocity is less than 0.2m/s, the airflow velocity should be increased. On the contrary, when the average airflow velocity is greater than 0.5m/s, it should be reduced.



Caution:

If there is any problem please contact your local dealer for installation adjustment.

Chapter 3 Operating Instruction

3.1 The Main Screen Introduction

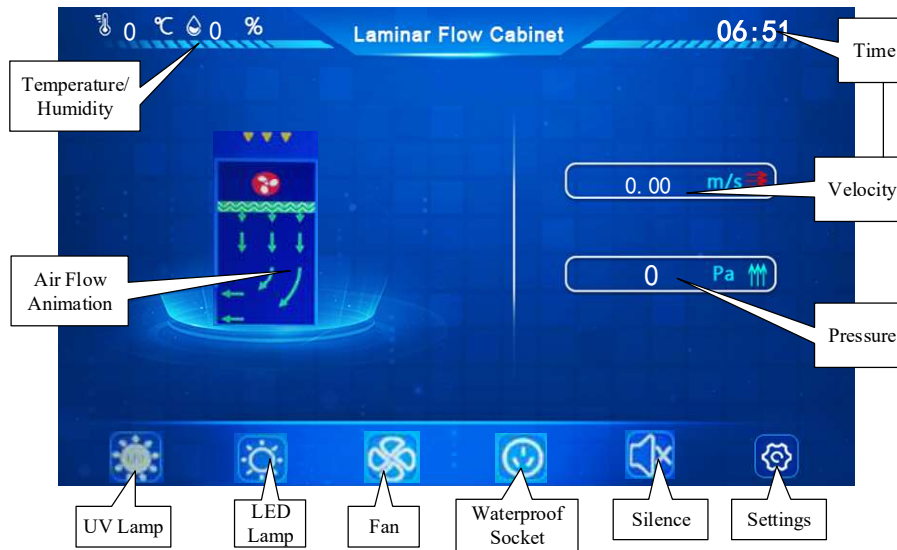

Figure 7 Main screen

- **Temperature and Humidity:** Real-time measurement and display of temperature and humidity in the operation area.
- **Air Flow Animation:** When the cabinet running, display the air flow direction, but if the fan is closed, the animation will stop.
- **UV Lamp:** Control the switch of UV lamp.

Note: UV lamp and front window have a chain mechanism, only when the front window down to the lowest can UV lamp be opened.

- **Fan:** Control the fan switch.
- **Silence:** Switch sound on and off. "×" is in front of the horn when the sound is off.
- **Settings:** After clicking "Settings", it enters the settings interface, which allows you to set the following contents of the cabinet: Timing switch, fan settings, equipment life, standby settings.
- **Pressure:** Real-time display of the pressure difference value before and after the filter.
- **Velocity:** Real-time display of vertical airflow velocity magnitude.
- **Time:** Real-time display of the current date and time.
- **LED Lamp:** Control the open and close of LED lamp.
- **Waterproof socket:** Control the power on and off of waterproof socket.

3.2 Settings Interface



Figure 8 Settings interface

Click "Settings" to enter the settings interface, in which you can set contents as shown in the figure.

3.2.1 Timing switch

Click "Timing Switch" in the above figure to enter the timing switch interface, click "Time Input/Display Area" to input the value to be timed, and then you can switch the timing for the corresponding time.

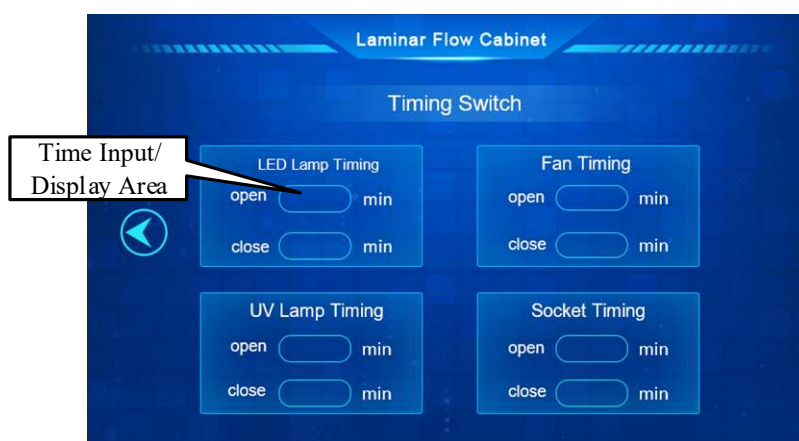

Figure 9 Timing switch

3.2.2 Standby settings

The standby time is the time when the screen is darkened and the equipment enters the screen protection state.

Click "Standby Settings" to enter the standby settings interface, click the number in the "Standby Time Display Area" to modify the standby time.

3.3 Introduction to the the usage process

- (1) Before the experiment: Lower the front window to the bottom, click the UV lamp, turn on the UV lamp, disinfect for more than half an hour.
- (2) You can manually lift the front window. When lift the front window to a suitable height, open the fan, you can start the experiment after running for half an hour.
- (3) After the experiment, lower the front window to the bottom, click the UV lamp, turn on the UV lamp and disinfect for more than half an hour.
- (4) After use, unplug the power supply and place it in suspension to avoid power contact

with moisture and water to avoid leakage.



Caution

-
- (1) When disinfecting, people should leave the room to protect their eyes and skin from inadvertent exposure.
 - (2) The intensity of the UV lamp is tested regularly according to the manufacturer's specifications, and it is recommended that it be tested once a quarter. If it fails to pass, replace it.
-

Chapter 4 Maintenance

The operability and safety of this cabinet can only be guaranteed if there are enough competent personnel and units for inspection, maintenance and repair.

4.1 Comprehensive Maintenance Cycle

Maintenance should be performed every week, every month, every year, every 1000 working hours and every restart.

4.2 Maintenance Methods

4.2.1 Cleaning

Under normal circumstances, cleaning only requires a small amount of household or commercial dishwashing detergent, which will be dissolved in water and wiped directly to wipe off the surface of the cabinet dirt.

(1) When the cabinet is used for the first time or long time out of use again.

You should first use a dry cleaning towel to remove the floating dust on the surface, after several cleanings by towel wipe, to confirm the dust-free then use medical alcohol spray on medical gauze to disinfect the operating area, laminar flow plate and work surface, to wipe the comprehensive. Before use, turn on the UV lamp to disinfect, after 30 minutes, turn off the UV lamp and press the fan key, the fan will run.

(2) When the Laminar Flow Cabinet is used continuously.

After using the laboratory clean work table every day, first clear all the debris on the work surface, wipe it again with a dry and wet cleaning towel, and finally disinfect the operation area, laminar flow plate and work table surface with medical alcohol spray on medical gauze, wipe it comprehensively to prepare for use on the next day.



Caution:

You can only spray alcohol on the medical gauze with alcohol spray, do not spray alcohol on the laminar flow plate, because the laminar flow plate has a HEPA, which can not be subject to moisture.

4.2.2 Regular maintenance

a. Daily or weekly cleaning in the process of use

Use medical alcohol to disinfect and clean the cabinet.

Disinfect and clean the operation panel with medical alcohol.

Use flexible cleaning agent or glass-specific cleaning agent to clean the outer surface of the area and glass.

Check each function of the cabinet according to the user manual.

b. Monthly cleaning

Surface cleaning.

Check functions of the cabinet, disinfection of the interior of the cabinet.

Record this maintenance process.

c. Annual maintenance

Check the firm station of steel wire ropes on the front window.

Check LED lamp tubes.

Conduct a thorough inspection of cabinet's performance for the safety of it. The maintenance fee is paid by the user.



Caution

- a. The power supply should be disconnected before performing routine maintenance.
 - b. Since the statistics of operating time will directly affect the judgment of maintenance needs, we suggest that a detailed record of operating time should be prepared for reference and inquiry when using this cabinet.
 - c. The fan must be inspected and maintained on a regular basis.
 - d. Surface cleaning: In order to keep the cabinet clean, please clean it regularly (at least once a week is recommended), wipe it with a soft cloth soaked with flexible cleaner and then wrung out and wiped. Please do not spray any chemicals on the operation panel or other labels to prevent discoloration of the label film or unclear writing. Clean the outer surface of the cabinet and the glass with a flexible cleaner or a special cleaner for glass.
-

Chapter 5 Handling of Common Problems

When there are doubts, suspicion of cabinet failure in the process of use, you can first refer to the following content to troubleshoot.

Before diagnosing the problem, please make sure that the power supply is connected, the power cord is not obviously broken, the fuse is good, and the power lock is in the open state.

Fault	Position	Judgement basis	Solution
LED lamp light is not light up or abnormal	The cabinet is equipped with an interlock program, when the UV lamp is turned on, it is normal to not be able to turn on the lighting, so make sure that the UV lamp is turned off.		
	Lamp tube	Check that the lamp tube is damage or not.	If it broken, replace lamp tube.
	Circuit	Check that the circuit is well connect or not.	If not, rewiring.
	Control board	Excluding other damage possibilities.	Replace control board.
UV lamp does not light up or abnormal	The cabinet is equipped with an interlock program, when the window is opened, the fan and the LED lamp is turned on, it is normal to not be able to turn on the UV lamp, so make sure that the window, the fan and the UV lamp are turned off.		
	Lamp holder	Check whether the lamp and the lamp holder are firmly connected.	If it broken, replace the lamp holder.
	Lamp tube	Check that the lamp tube is damage or not.	If it broken, replace the lamp tube.
	Ballast	Check that the ballast is damage or not.	If it broken, replace the lamp tube.
	Circuit	Check that the circuit is well connect or not.	If not, rewiring.
	Control board	Excluding other damage possibilities.	Replace the control board.
Fan is not work	The equipment is equipped with an interlock program, when the UV lamp is turned on, it is normal to not be able to turn on the fan, so make sure that the UV lamp is turned off.		
	Fan	Check that the fan is damage or not.	If broken, replace the fan.
	Circuit	Check that the circuit is well connect or not.	If not, rewiring.
Touch screen control is not sensitive	Circuit	Check that the circuit is well connect or not.	If not, rewiring.
	Touch screen	Excluding other damage possibilities.	Replace the control board.
Waterproof socket is not energized	Fuse of waterproof socket	Check that the fuse is intact or not.	If broken, replace the fuse.
	Waterproof socket	Check that the splash-proof socket is damage or not.	If damage, replace the waterproof socket.

	Circuit	Check that the circuit is well connect or not.	If not, rewiring.
	Control board	Excluding other damage possibilities.	Replace control board.
The cabinet is power-off	Power supply	Check that the power supply is well connect or not.	Reconnect the power supply.
	Power cord	Check that the power cord has obvious damage or not.	If it has, replace the power cord.
	Fuse	Whether fuse is good.	If damage, replace the fuse.
	Transformer	Whether transformer output is normal or not.	If not, replace the transformer.
	Control board	Excluding other damage possibilities.	Replace control board.



Caution:

- a. The operation of the above electrical components must be carried out by a qualified electrician under safe conditions (cut off the power). And other parts are not allowed to disassemble, otherwise the consequences are borne by the user.
- b. If there is other failure that is not in above list, or the operator can not immediately exclude, please immediately notify our company's maintenance department. Please do not repair the cabinet yourself for the sake of your safety.
- c. The maintenance of this cabinet should only be undertaken by trained and approved technicians.
- d. If you need to order parts, you can inform our technical service department, and indicate us the model and number of the Laminar Flow Cabinet you have purchased please.

Chapter 6 Simple Parts Replacement

Operation of all electrical components of the cabinet must be carried out by a qualified electrician under safe conditions. When the cabinet has malfunction and the operator can not immediately troubleshoot, please notify the maintenance personnel immediately. Please do not repair the cabinet by yourself for your safety.

If you need to order parts, you can find our technical service department, inform us of the model and number of the Laminar Flow Cabinet you have purchased.

6.1 Replace the Fuse

Socket fuse [$\Phi 5 \times 20(5A)$] is located on the right side of Laminar Flow Cabinet. When you replace it, first turn off the power and unplug it, use a cross screwdriver to press and screw the fuse seat counterclockwise, take off the fuse in the fuse seat and replace it with a new fuse of same specification, then press and screw the fuse seat back clockwise; fire line fuse [$\Phi 5 \times 20(10A)$] is also located in the right side of cabinet, use a screwdriver to remove the fuse and replace the fuse with a new one, then press it back.

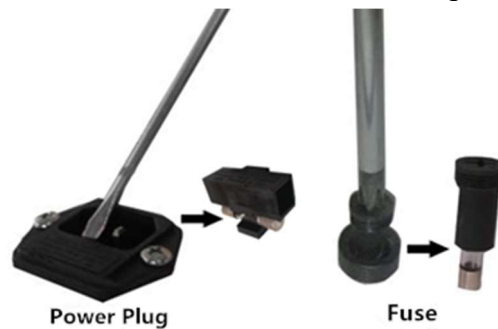

Figure 10 Fuse replacement

6.2 Replace the UV Lamp

The product is equipped with life of UV lamp for a cumulative working time of 600 hours. We recommend that you regularly test the UV intensity in order to achieve good disinfection effect. You can use the UV intensity test card to confirm whether you need to replace the UV lamp or not. When replacing, first disconnect the power supply, then remove the lamp by screwing it 90°, take out a new UV lamp of same specification, put it on the lamp holder and screw 90° in the opposite direction.

Put your hands on both ends of the lamp that near both sides of the lamp holder, and at the same time rotate the lamp clockwise (or counterclockwise) for 90°, then the lamp can be removed as shown, carefully placed aside, take out a new UV lamp and insert it into the lamp holder, rotate 90° clockwise (or counterclockwise). When installation is complete, turn power on to test.



Figure 11 UV lamp replacement

6.3 Replace the LED Lamp

When LED lamp cabinet needs to be replaced, please disconnect the power supply. Then tilt the LED integrated bracket to remove, unplug the right side, replace the new LED bracket and then tilt the card into the slot.

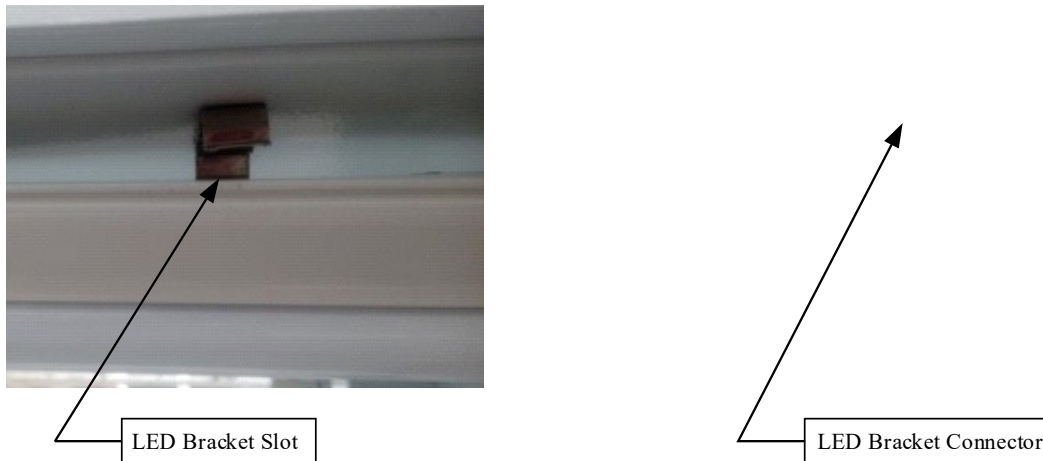

Figure 12 LED lamp replacement



Caution:

- (1) It is forbidden to wipe the lamp body with a wet cloth while cleaning in the powered state.
 - (2) Prohibit the replacement in the powered state.
-

Chapter 7 Caution

7.1 Storage Conditions

The Laminar Flow Cabinet should be stored in the warehouse with relative humidity not more than 75%, temperature less than 40°C, good ventilation, no acid, alkali and other corrosive gases. The storage cycle should not exceed one year. If it stored for more than one year, the open-package inspection is needed and only passed the inspection can it enter the circulation field.

7.2 Transportation Conditions

The cabinet should be transported in full accordance with the requirements shown on the outer surface of the packing area. The user should check the integrity of the packing area carefully when receiving the cabinet with packing area sent by the logistics company. If the packing area has damage, extrusion and other phenomena, please refuse to sign, and contact with our company in time.



Caution:

Please contact with us in time when the cabinet that has been installed and used is relocated and moved again.

7.3 Caution

(1) Before connecting the AC power supply, you need to ensure that the voltage of the power supply is consistent with input voltage and it is stable, and ensure that the rated load of the power socket is not less than the requirements. The Laminar Flow Cabinet adopts grounding plug, which has the third leg that could only match with grounding type power socket, so it is a safety cabinet. If the plug can not be inserted into the socket, you should ask an electrician to install a grounding type power socket. Be sure to confirm good grounding when using.

(2) During the using process of the cabinet, do not put soft, fine items (for example: soft tissue paper) on the countertop, avoid sucking them into the negative pressure duct and fan by the inlet, which can affect the operation of the cabinet.

(3) The maximum weight of items placed in the cabinet should not exceed 23kg/25×25cm².

(4) Avoid vibration: Avoid the use of vibrating equipments (such as centrifuges, vortex oscillators, etc.) in the cabinet, because vibration will make the particulate matter accumulated on the filter membrane shake off, resulting in the reduction of cleanliness inside the operating area. At the same time, if there is former operating surface balance failure, it will also cause Laminar Flow Cabinet contaminate to the operator.

(5) Open flame is prohibited: The use of open flame is prohibited in the Laminar Flow Cabinet. The use of open flame will lead to flocculation of airflow in the operating area, and will damage the filter. During the process of experiments that requiring high temperature sterilization, it is highly recommended to use infrared sterilizer.

(6) HEPA has service life. With the extension of the use period, dust and bacteria accumulation in the filter will lead to the increase of pressure loss of HEPA. When the increase of the velocity can not meet the requirements, you must promptly contact our service department to replace the HEPA, otherwise it will affect the safety of the cabinet.

Replaced filter should be disposed according to the medical waste.

(7) The fan and its lower side steel plate is the static pressure area cover, these air ducts are strictly sealed when leave factory and needed to maintain their tightness. The operator should not loosen or remove the screws of these parts. If there is a special need, it must be handled by our service personnel.





(8) The storage period of the cabinet is one year. When it exceed the storage period, it must be opened and inspected once by the company's technical personnel, only qualified can it be used.

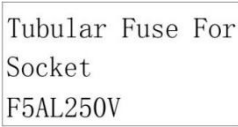

Caution:

Solemnly declare: If the cabinet is not used in accordance with the methods prescribed by our company, it may damage the protection provided by the cabinet, and our company should not be responsible for the risks caused by the operation that not in accordance with the provisions!

Chapter 8 Label Description

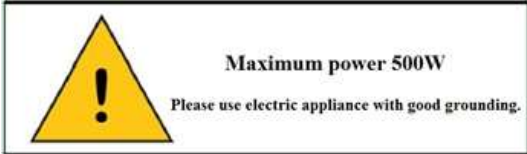
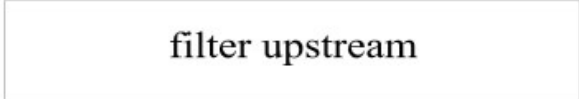
	<p>10A Fuse Label</p>
	<p>5A Tubular Fuse for Socket Label</p>
<p>Tublar Fuse For Blower F10AL250V</p>	<p>10A Tubular Fuse for Blower Label</p>
	<p>Grounding Label</p>
	<p>Over-height Warning Label for Front Window</p>
	<p>Warning Film for Front Window</p>
	<p>UV Lamp Warning Label</p>
	<p>Load Requirement Label</p>
	<p>Filter Upstream Label</p>

Chapter 9 Warranty Commitment

- The warranty period of the purchased product and maintenance contents are subject to the sales contract.
- In the warranty period of the cabinet, if the user improper use caused by failure or damage, our company does not assume warranty obligations.
- Out of the warranty period, our company is also responsible for maintenance, but charged the corresponding maintenance fees.
- The service life is 8 years, production date see product label.
- Our company trains and approves the maintenance unit and maintenance personnel to provide drawings and some necessary technical data of the cabinet.

Appendix Wiring Schematic Diagram

