

S-10

CONSTRUCTION MANUAL

DOCYKE



安装时间/Time to build: 90 min
最大载重/Max weight: 50Kg

1

装配时螺钉需要拧紧。

Tighten the bolts with full force to prevent them coming loose.

A

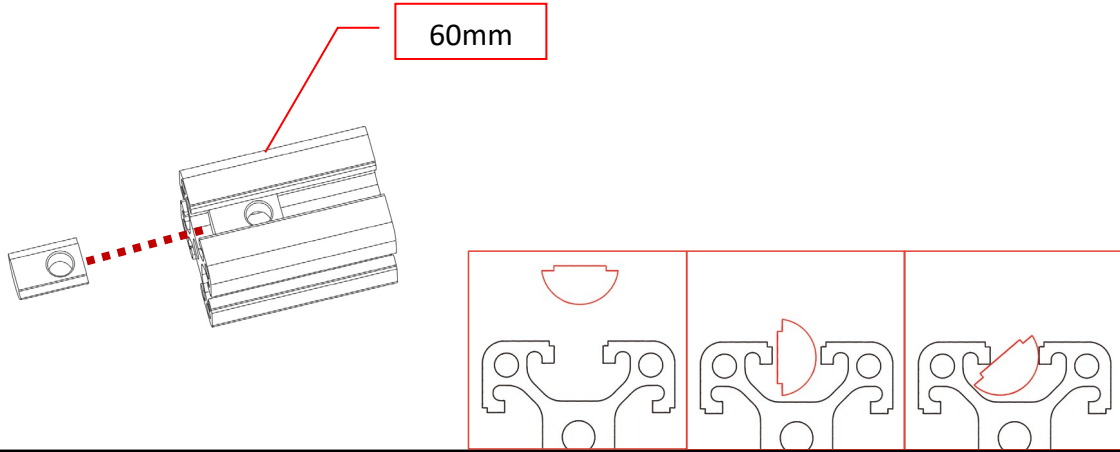

B

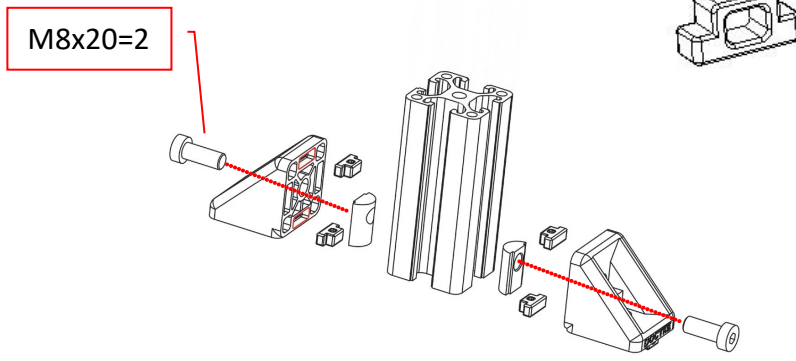

产品中一共包含两种定位块，它是至关重要的部件，请仔细分辨，避免漏装或误装。

The positioning blocks are some of the smallest parts but they also some of the most important. Putting them in the right place is a key of the DOCYKE.

C

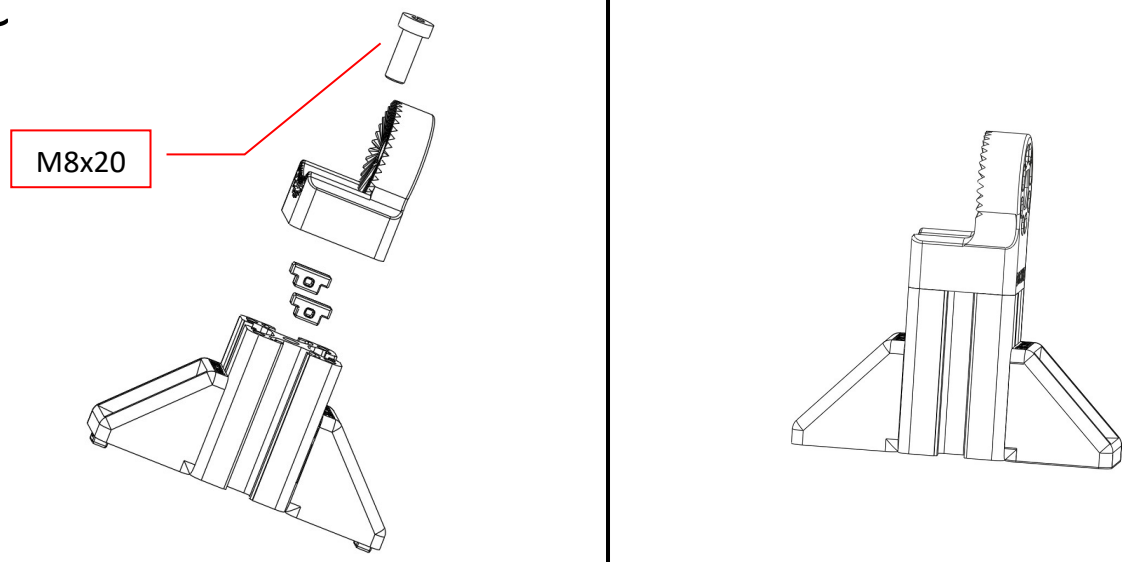

A

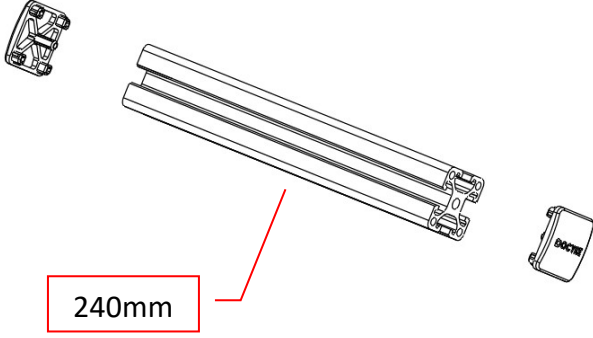

B

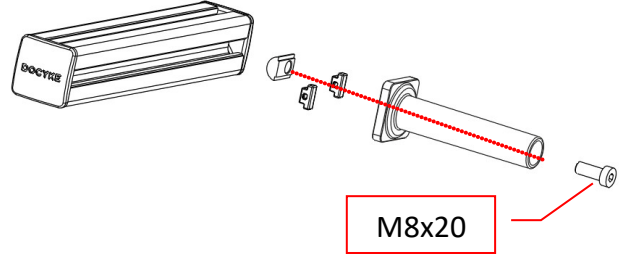

C

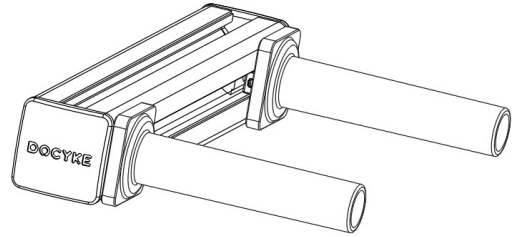
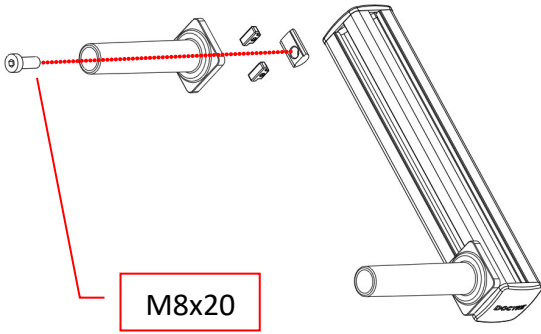

D

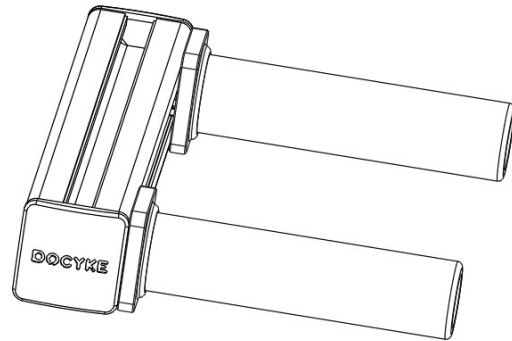
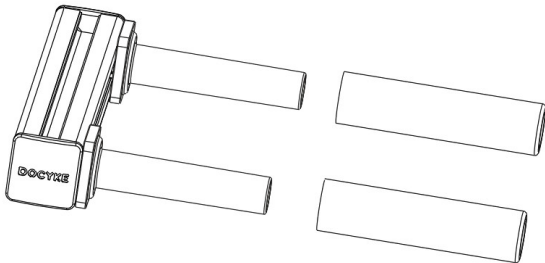

3

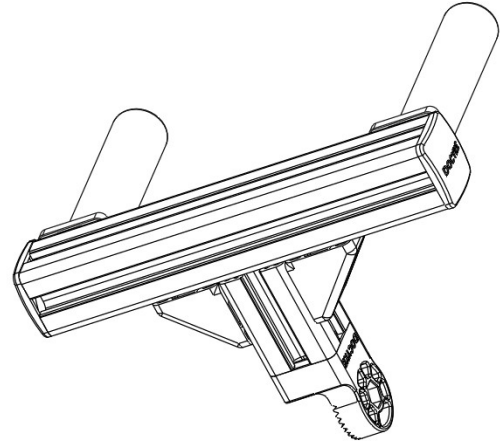
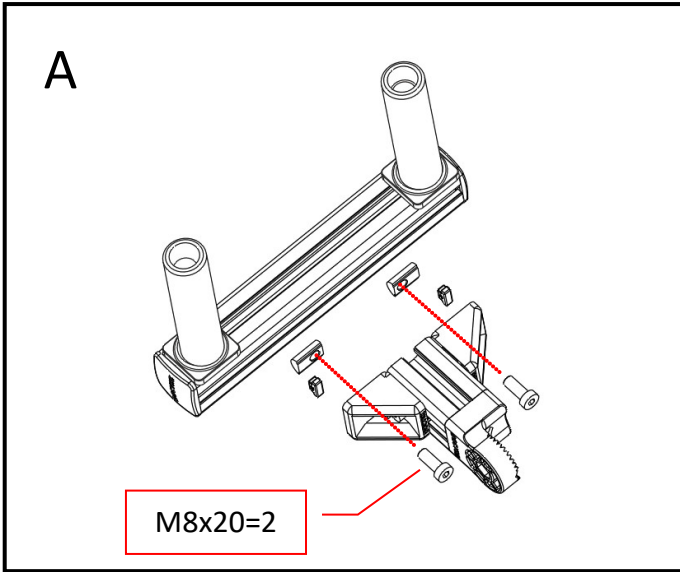

4

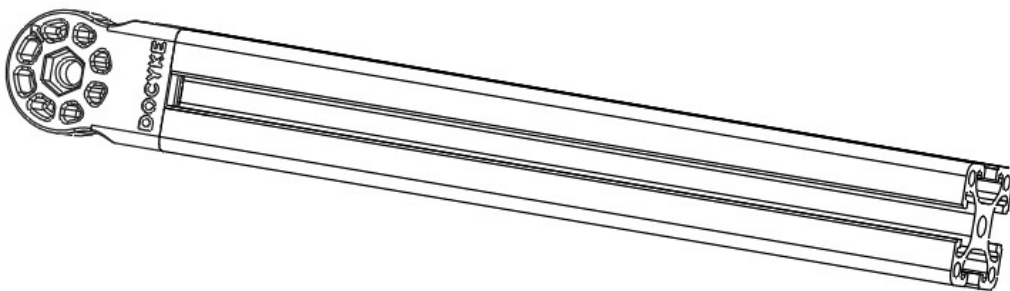
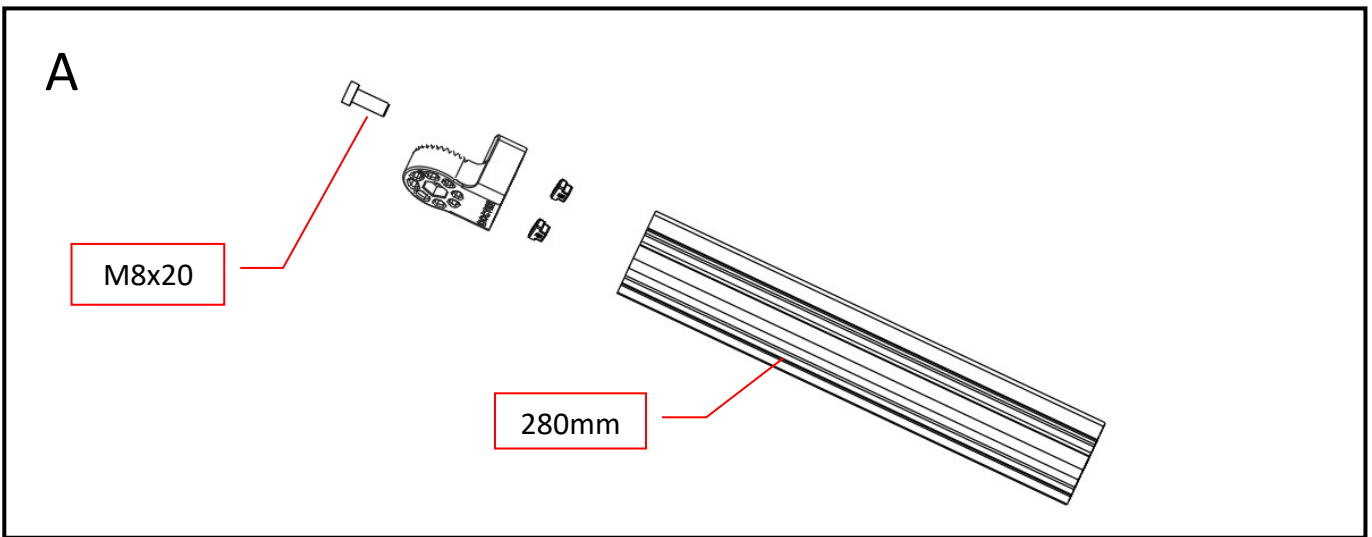

5

A



B

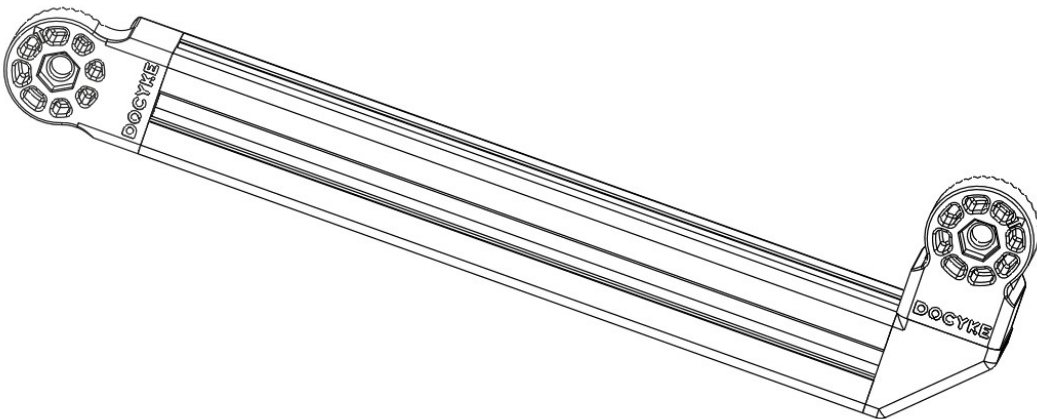
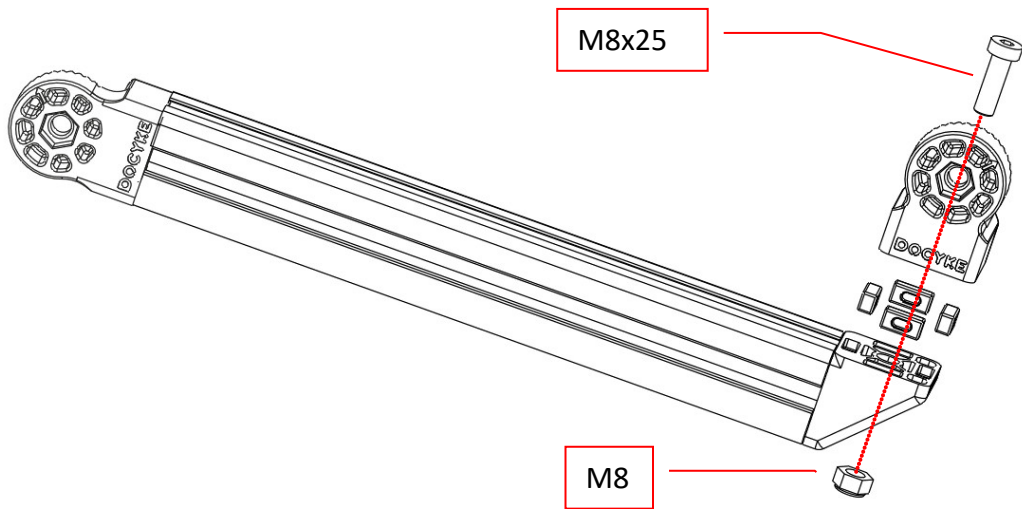

角度片的齿型分 2 种：
 一种可安装成 5°，15°，25°.....等
 一种可安装成 10°，20°，30°.....等

A

There are two types of knurled discs :
 One can be installed in 5°，15°，25°，etc.
 The other can be installed in 10°，20°，30°，etc.

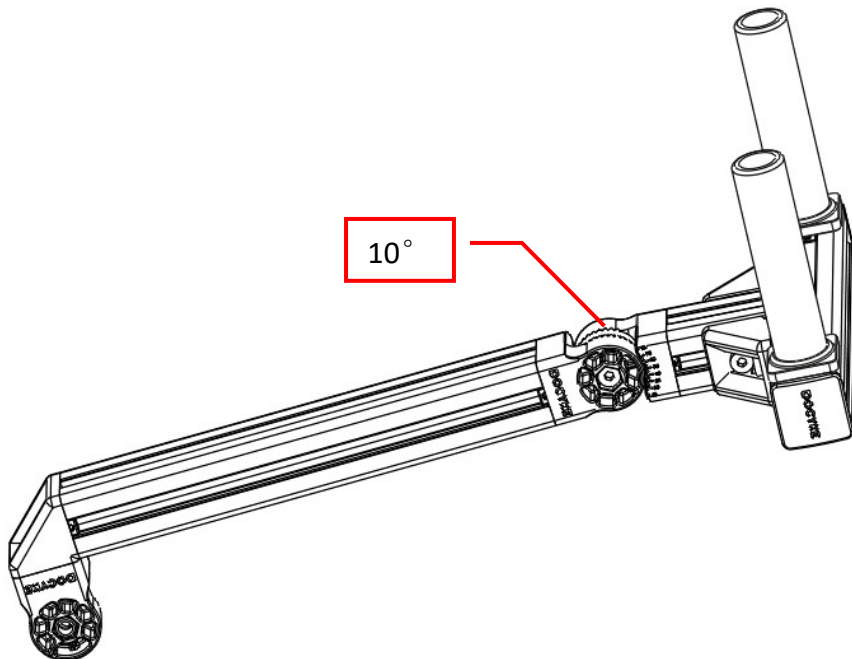
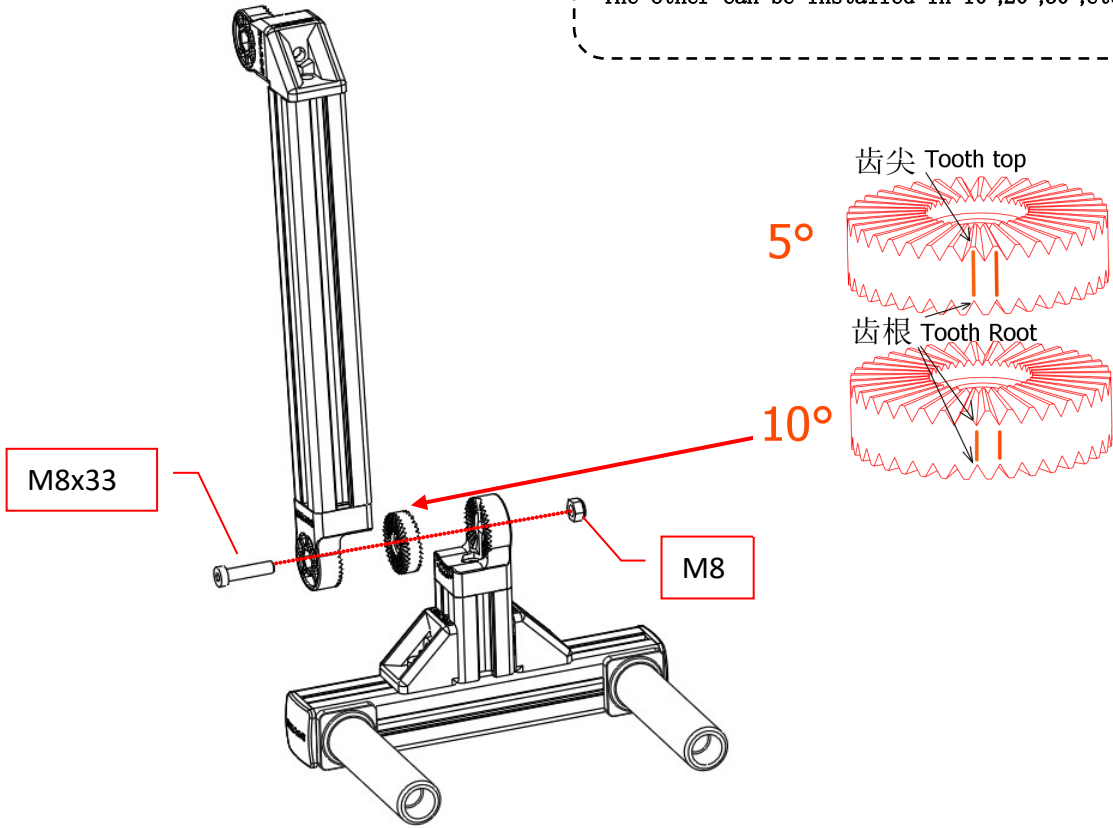

7

A

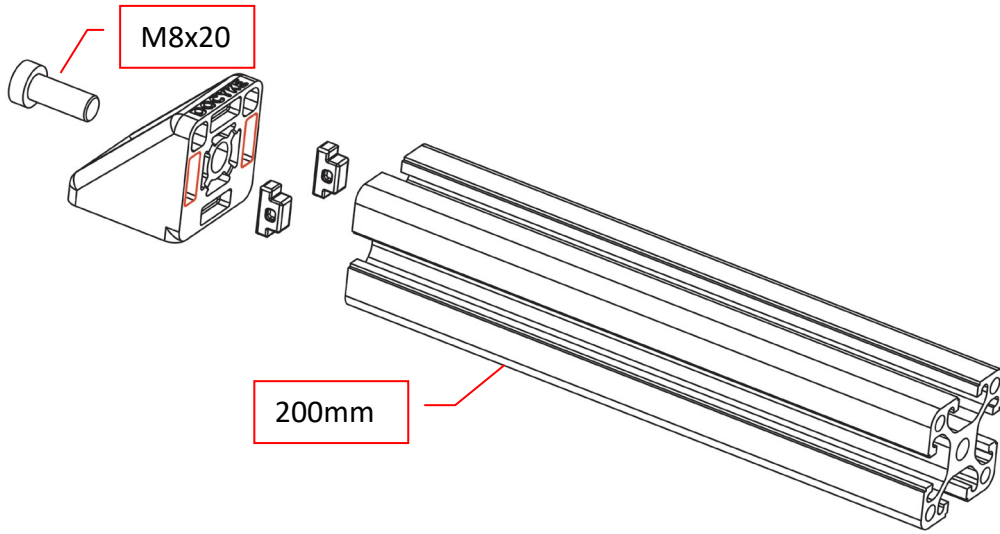

B

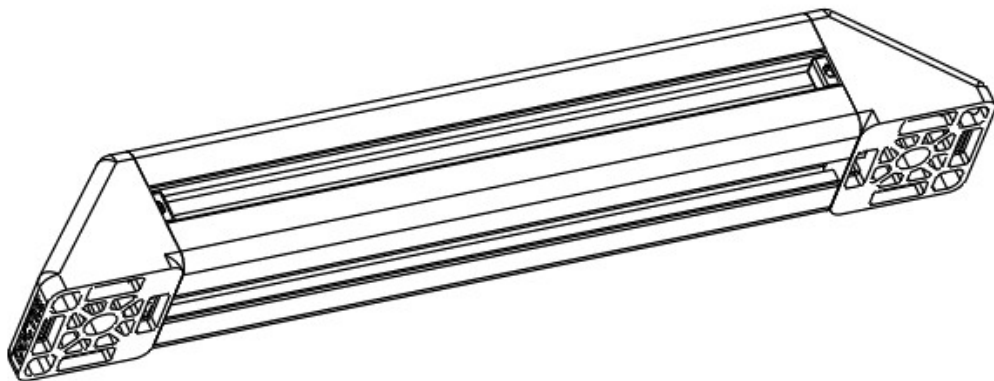
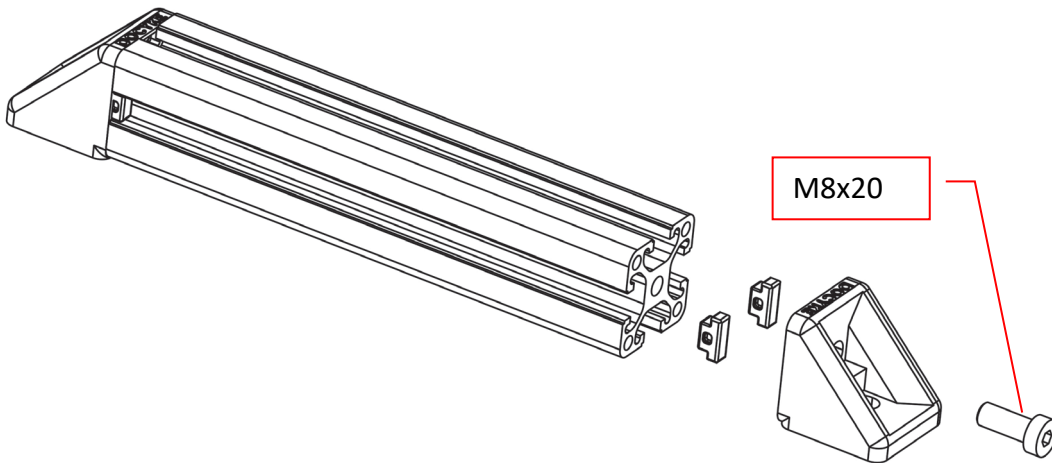

8

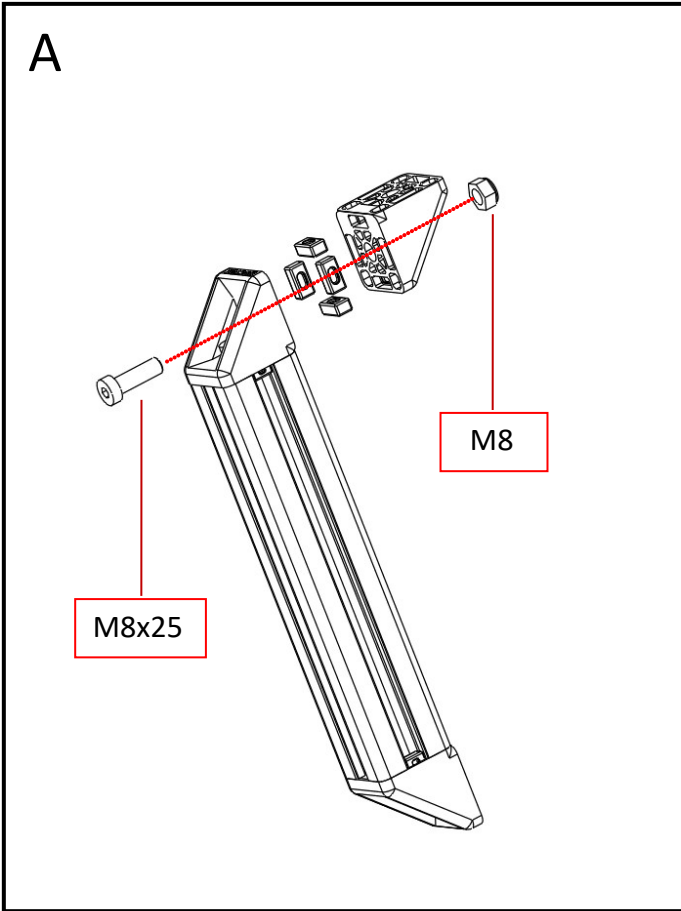

重复上述步骤。
Repeat the steps as figure.

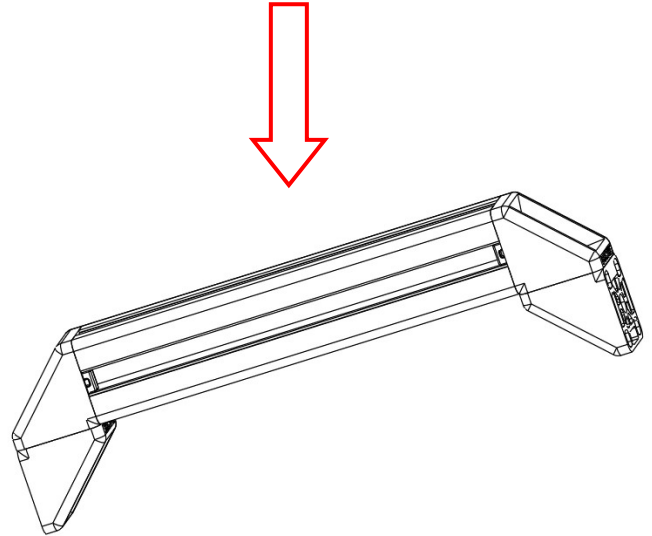

9

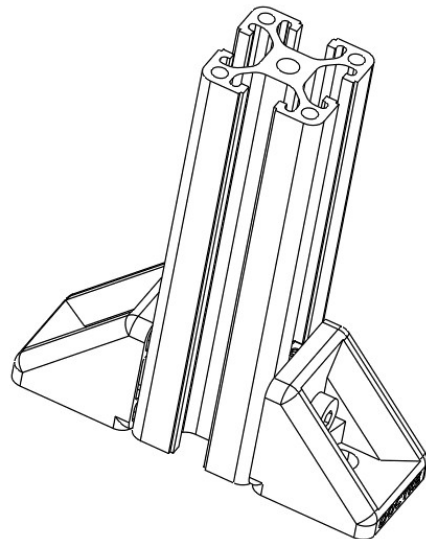
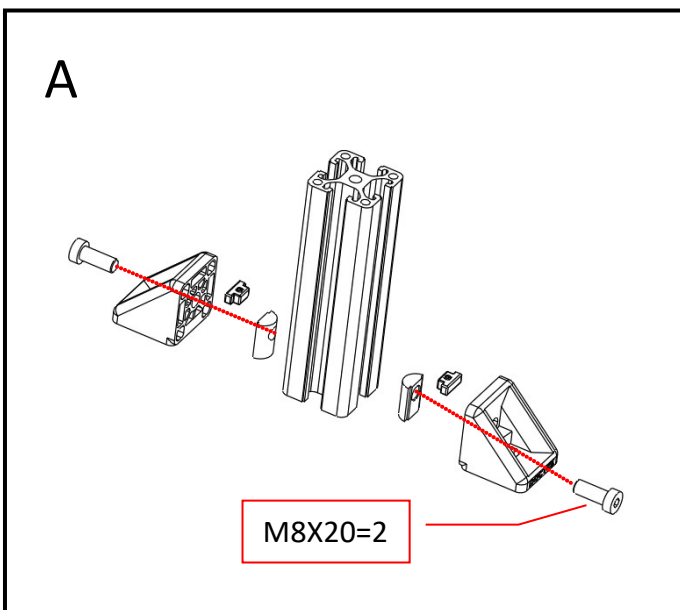

10

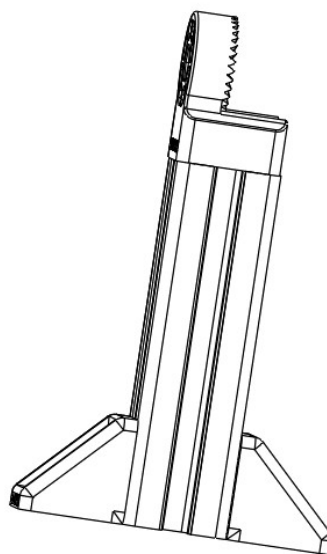
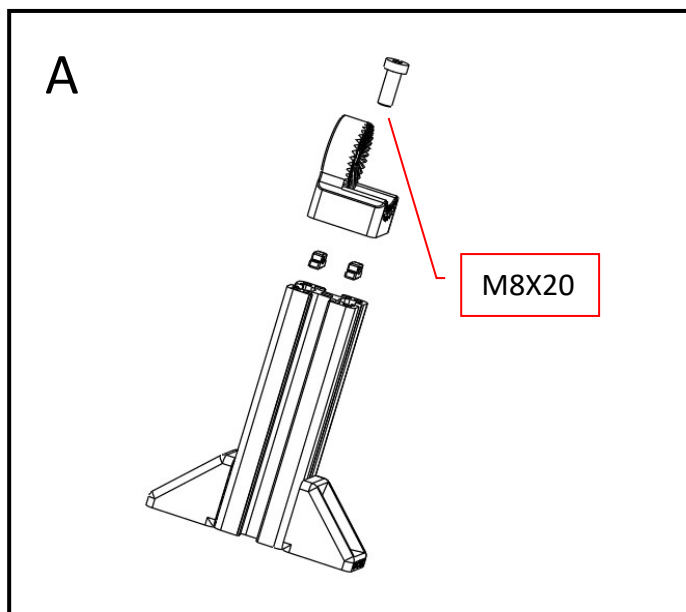

11

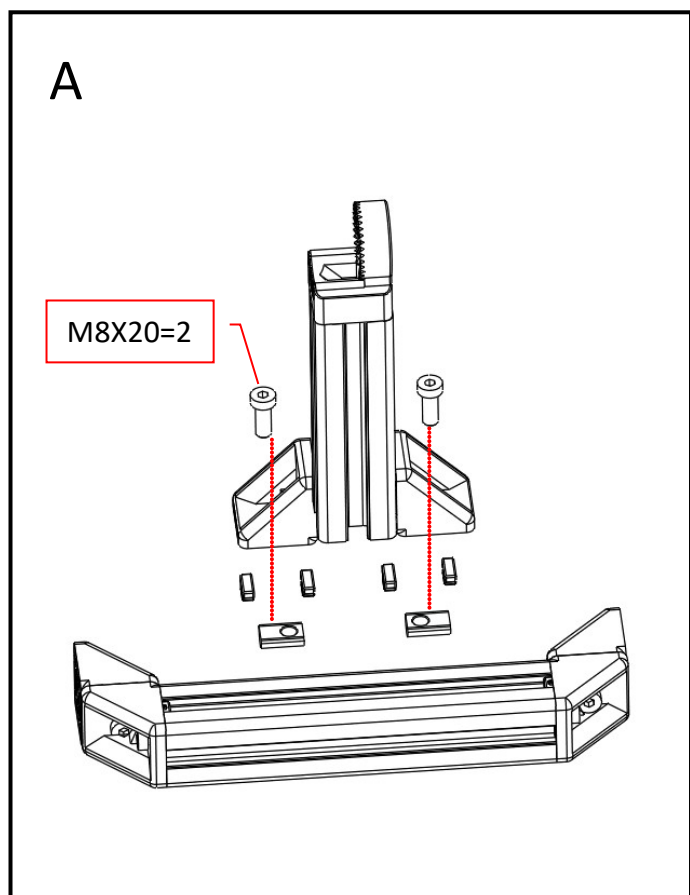

装配时螺钉必须拧紧。
Tighten the bolts with full force to
prevent them coming loose.

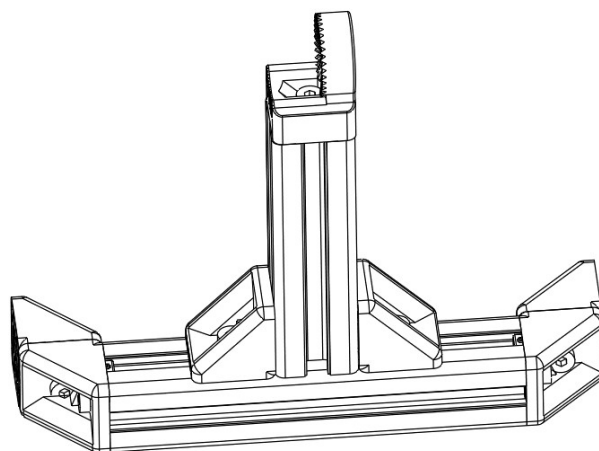

A

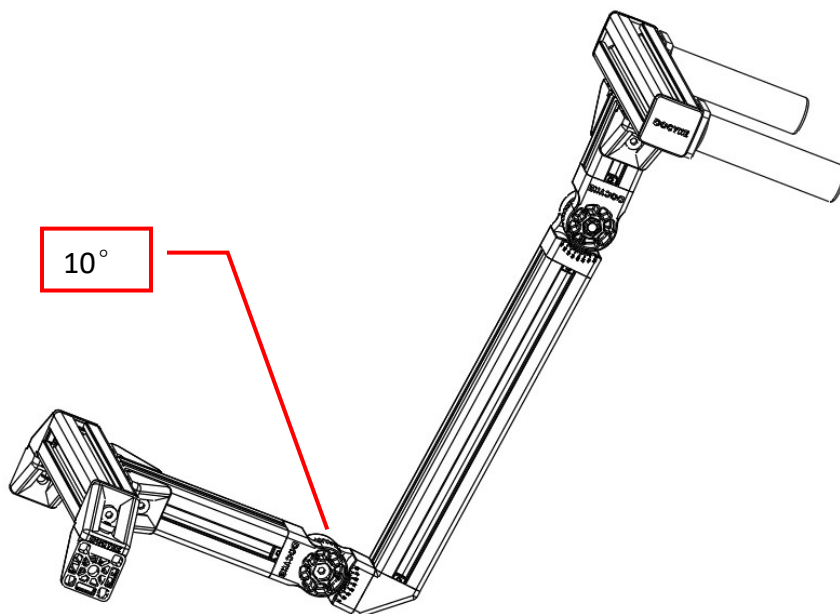
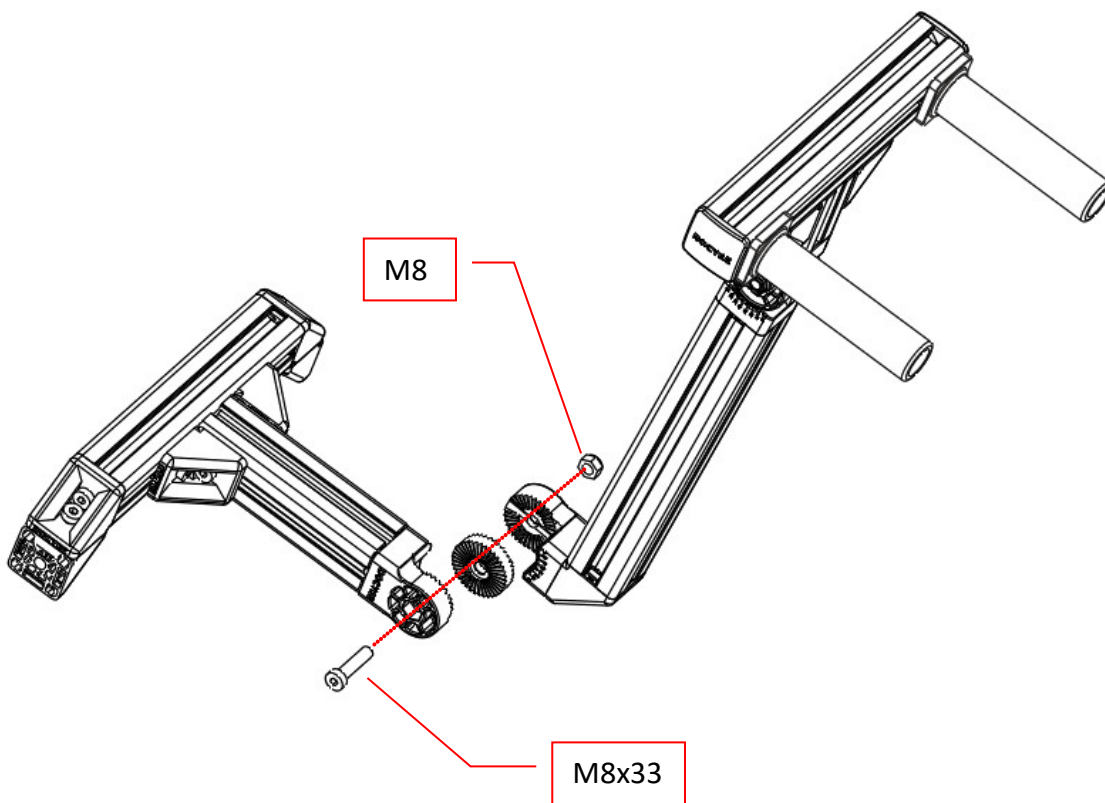

A

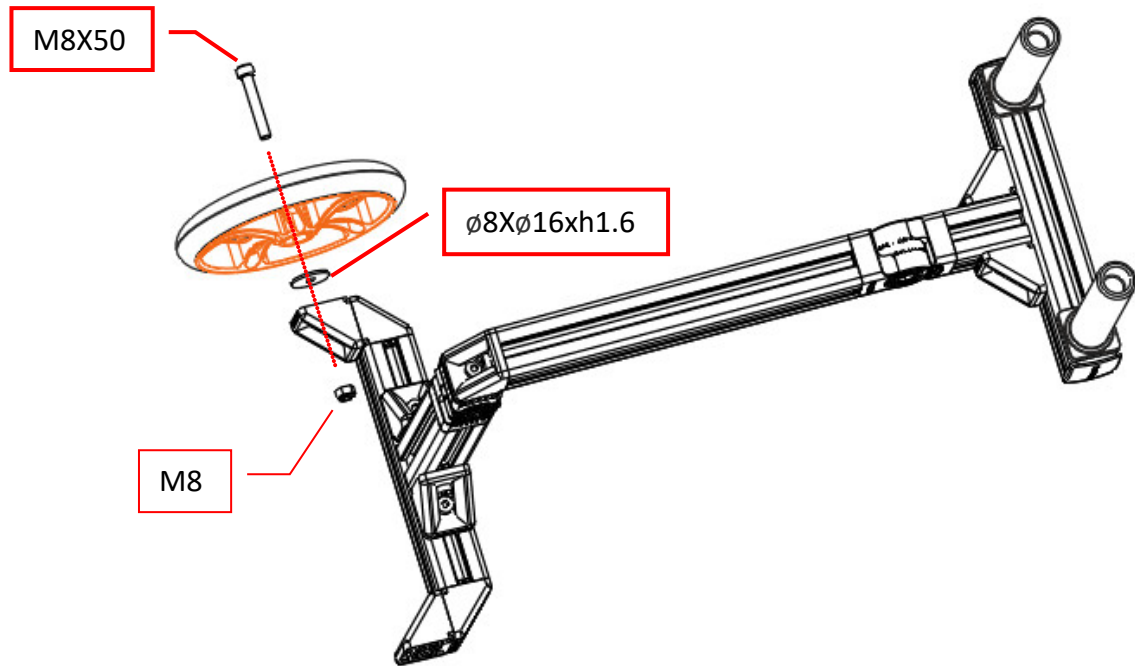

重复上述步骤。
Repeat the steps as figure.

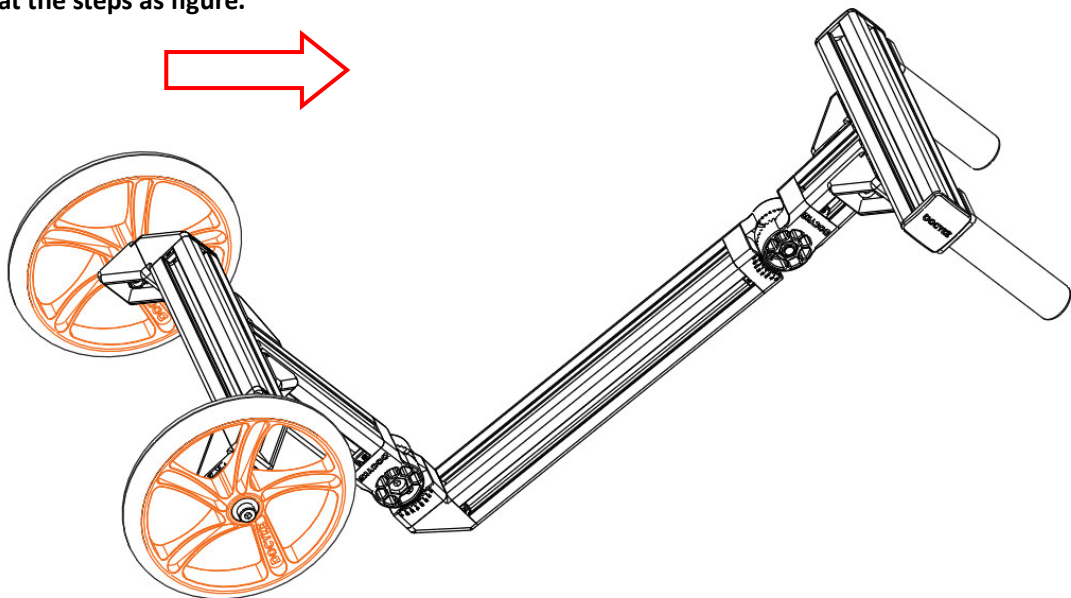

14

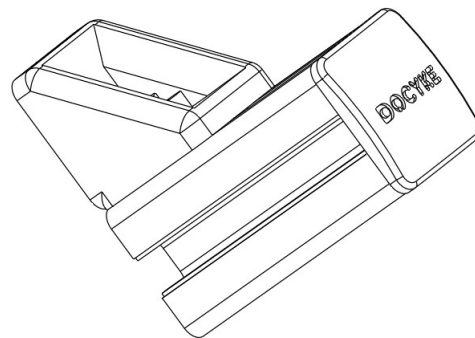
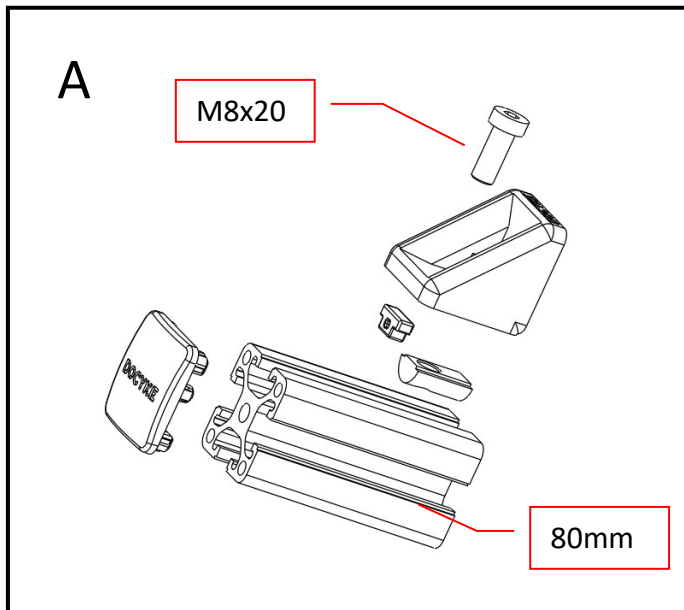

15

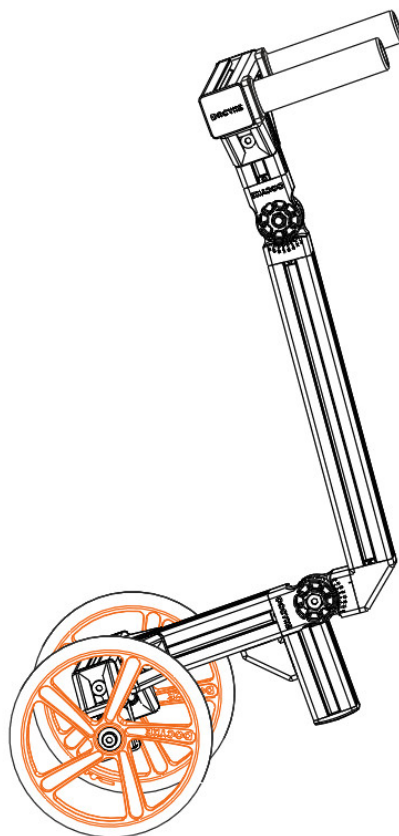
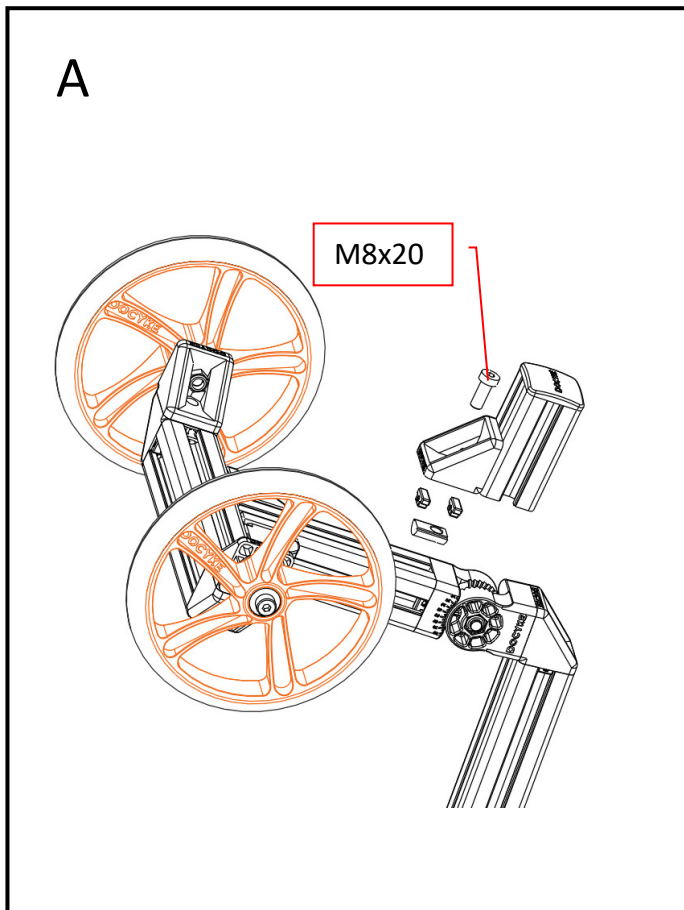

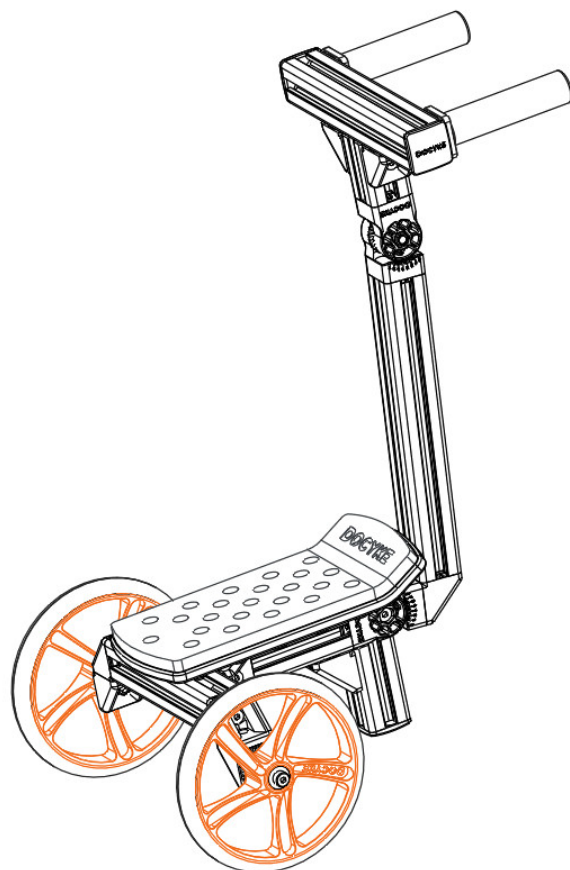
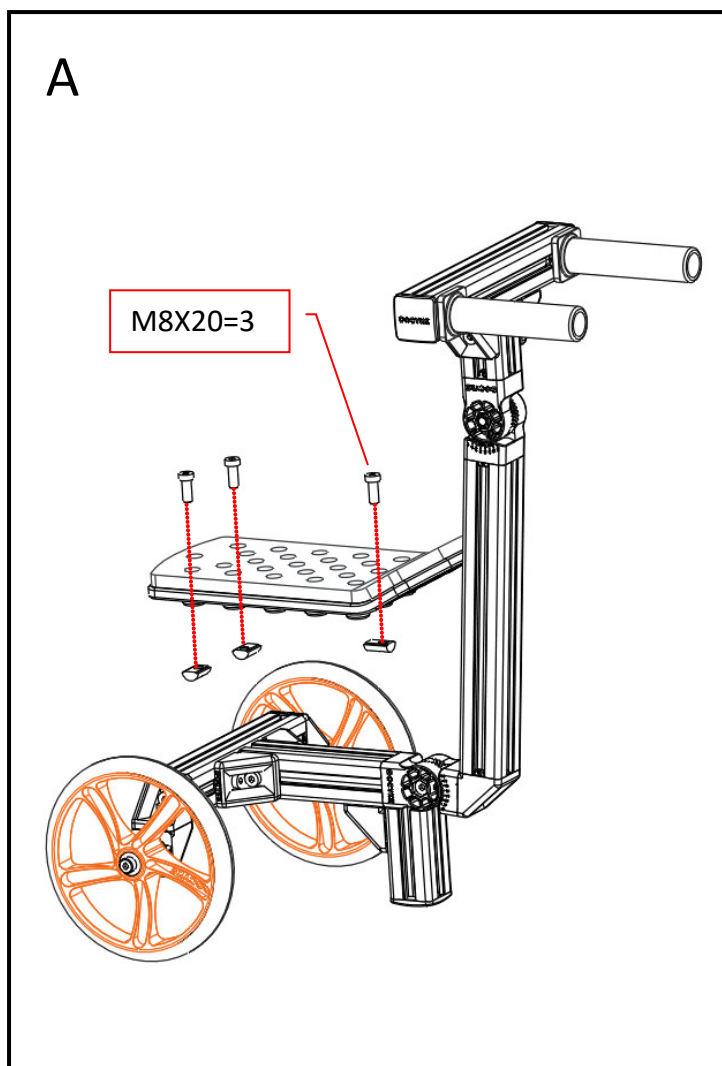

如果您有任何问题，或者更好，更酷的创意，欢迎联系我们。

If you have any questions, or better ideas, welcome to
contact us. www.DOCYKE.com

S-10

Max weight=50kg

