

L-08

CONSTRUCTION MANUAL

DOCYKE



安装时间/Time to build: 120 min

最大载重/Max weight: 30Kg

1

装配时螺钉需要拧紧。

Tighten the bolts with full force to prevent them coming loose.

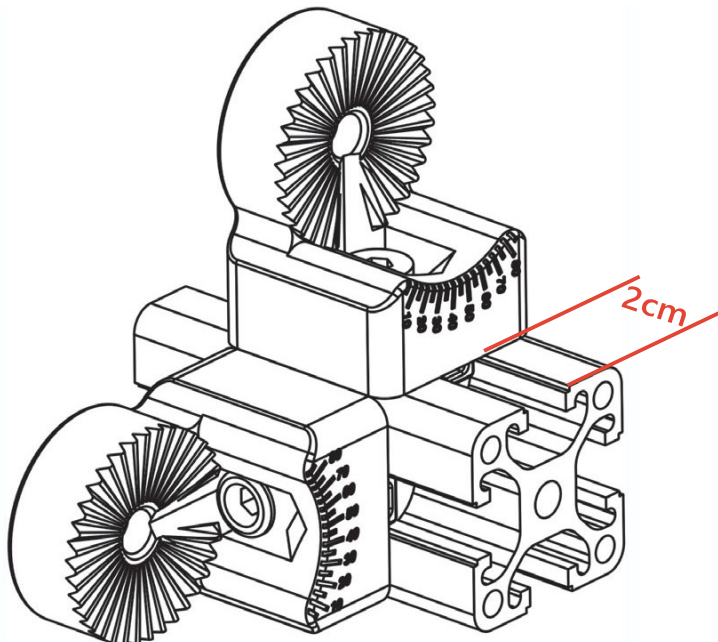
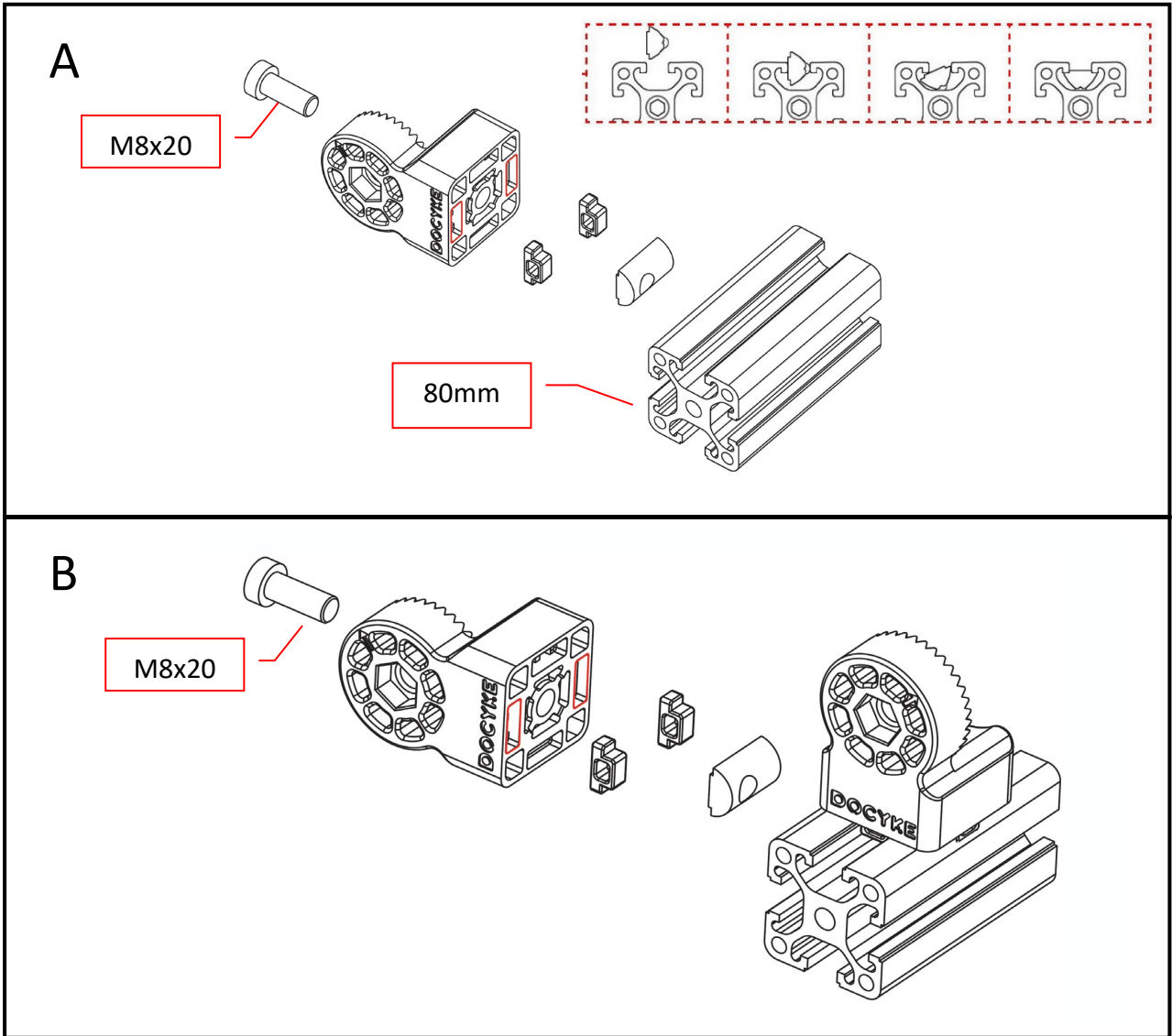

产品中一共包含两种定位块，它是至关重要的部件，请仔细分辨，避免漏装或误装。

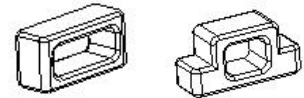

The positioning blocks are some of the smallest parts but they also some of the most important. Putting them in the right place is

2

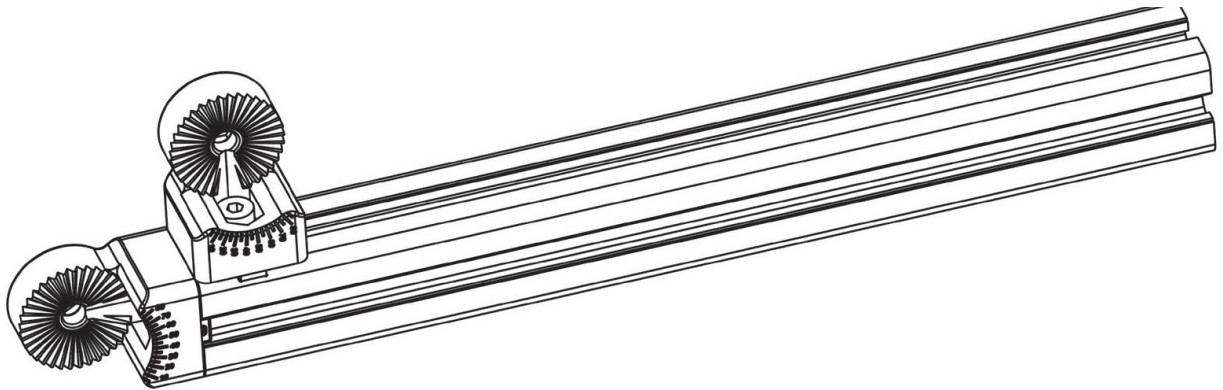
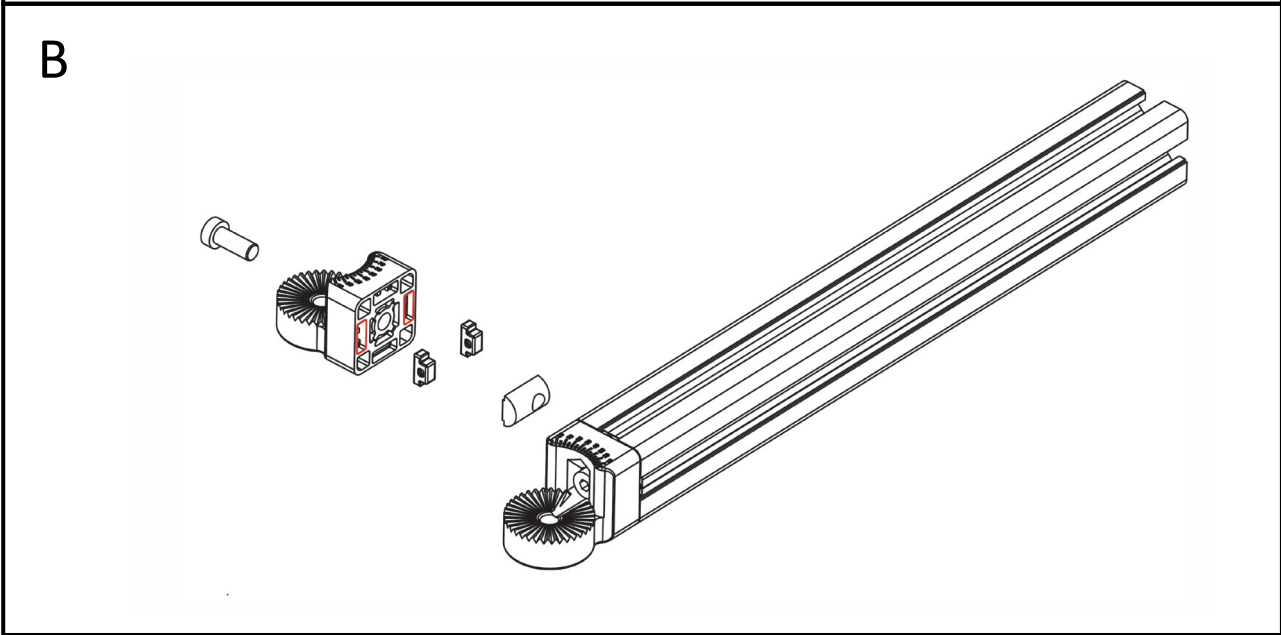
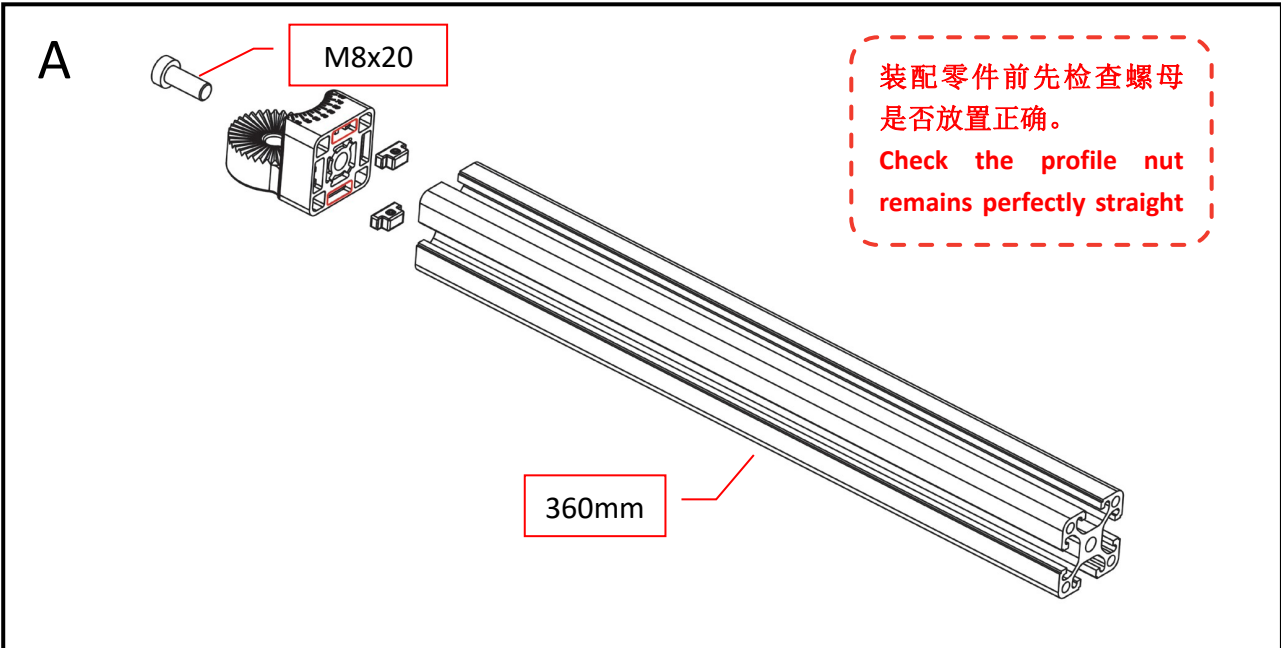

3

产品中一共包含两种齿片：

第一种使角度座按 5,15,25,35,45, 等等依次调整。

第二种使角度座按 10,20,30,40, 等依次调整。

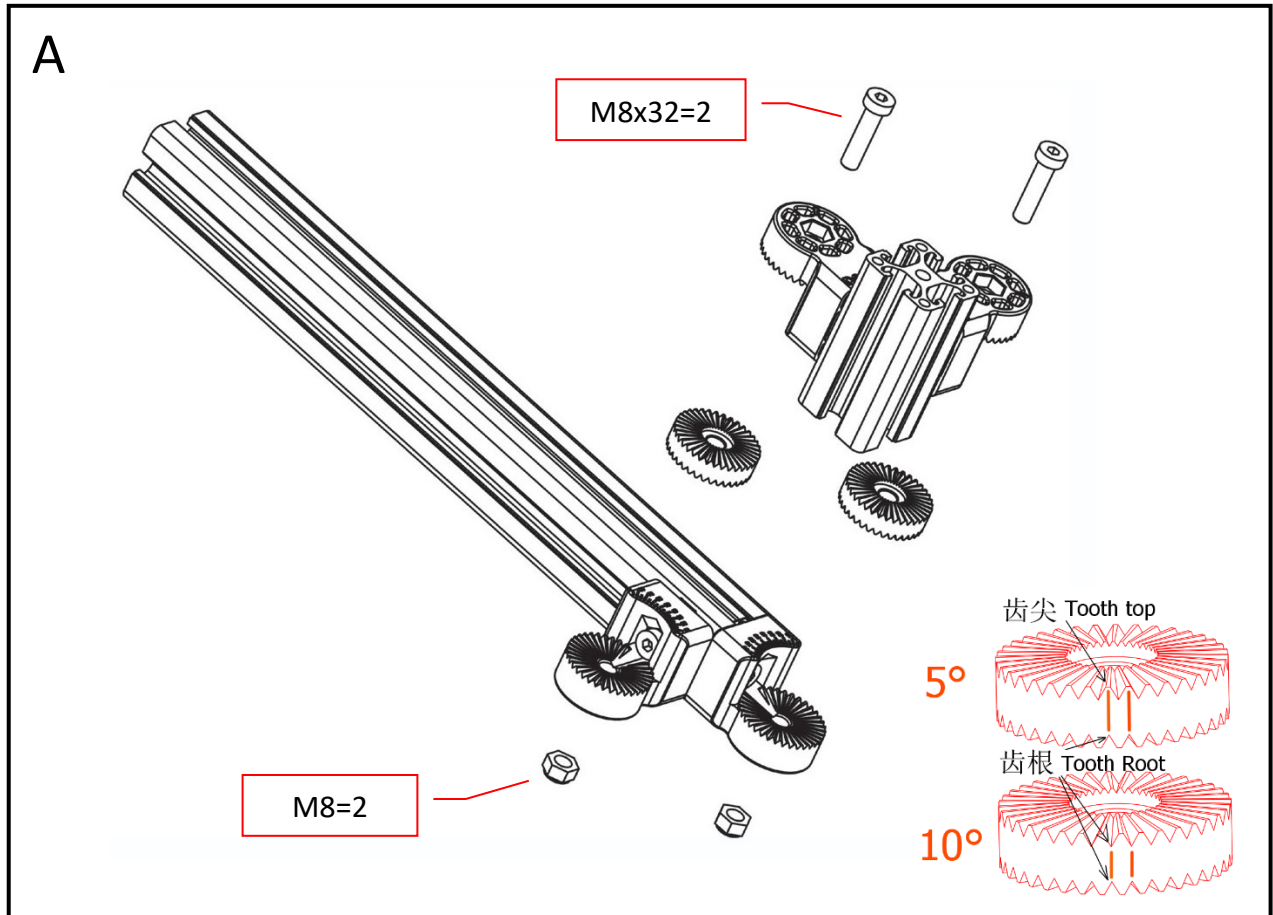

There are two different knurled discs.

One for each corner ending in a 5(5-15-25-etc. degrees)

One for each corner ending in a 10(0-10-20-etc. degrees)

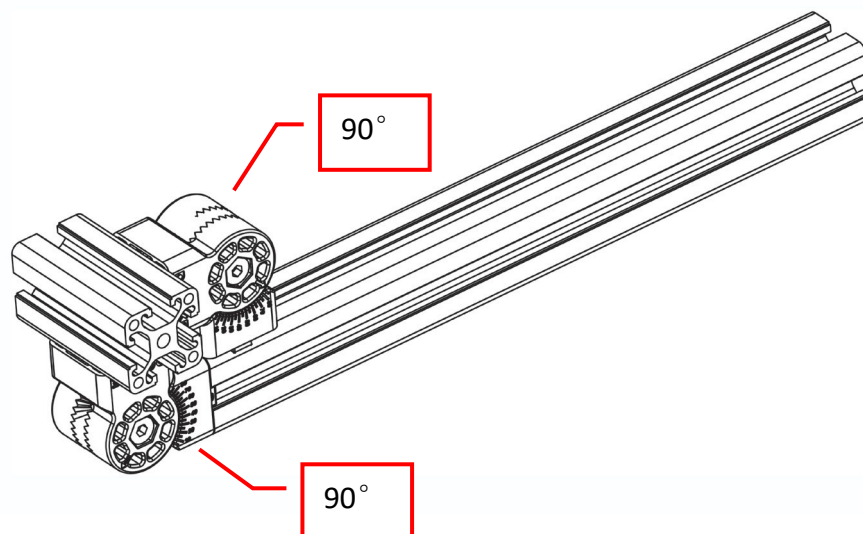

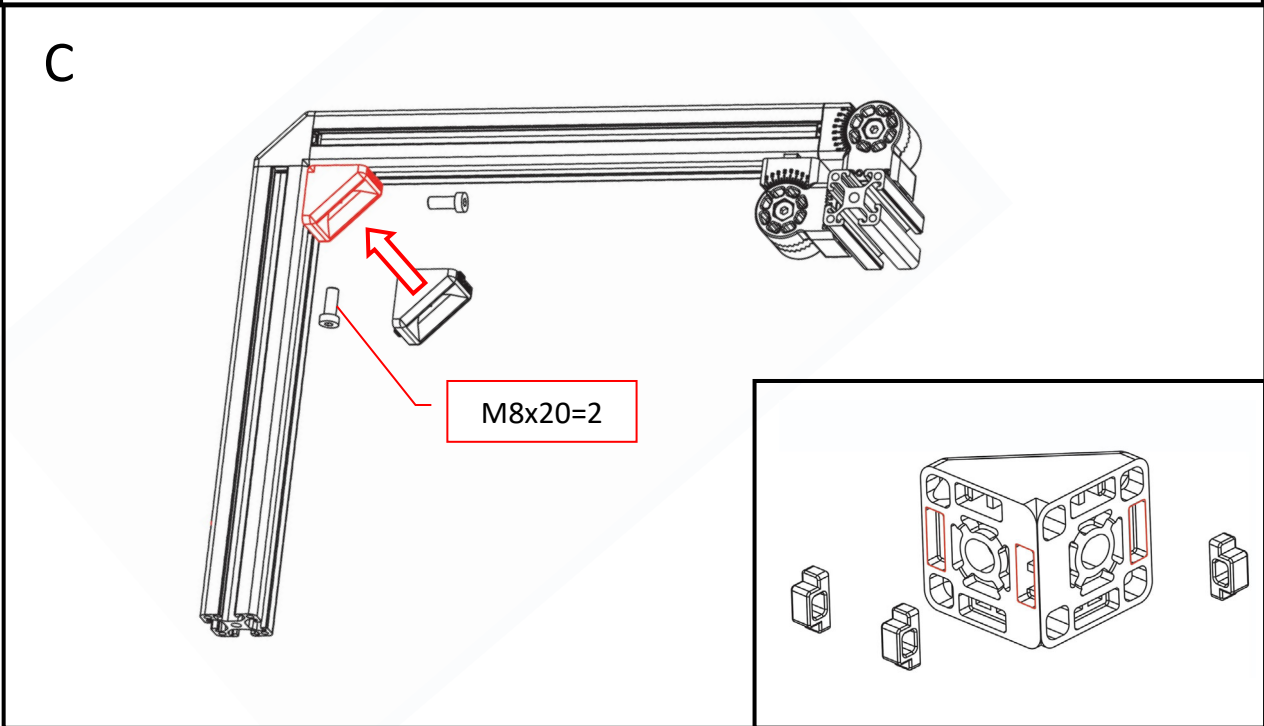
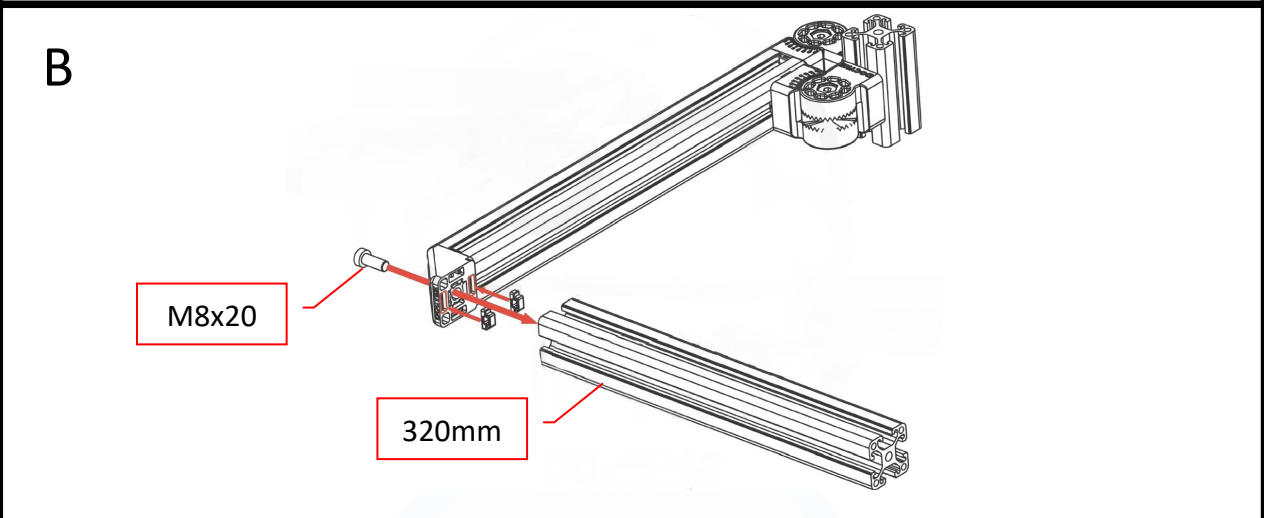
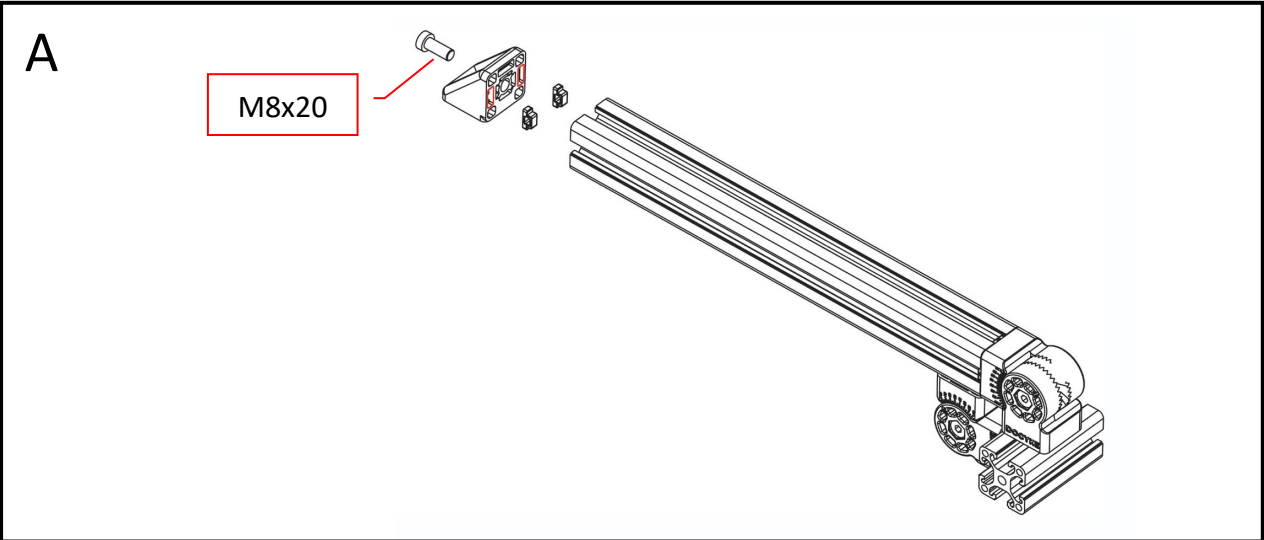

5

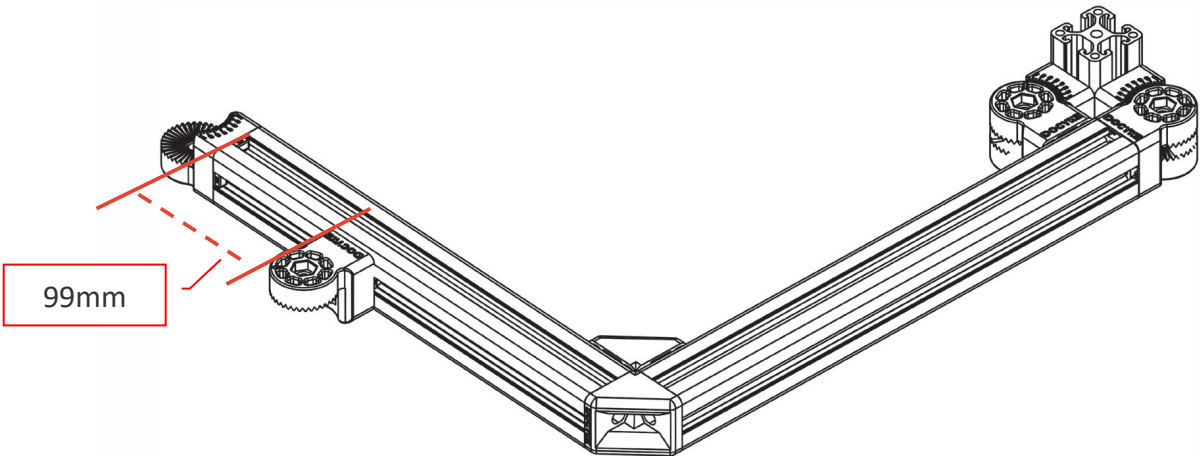
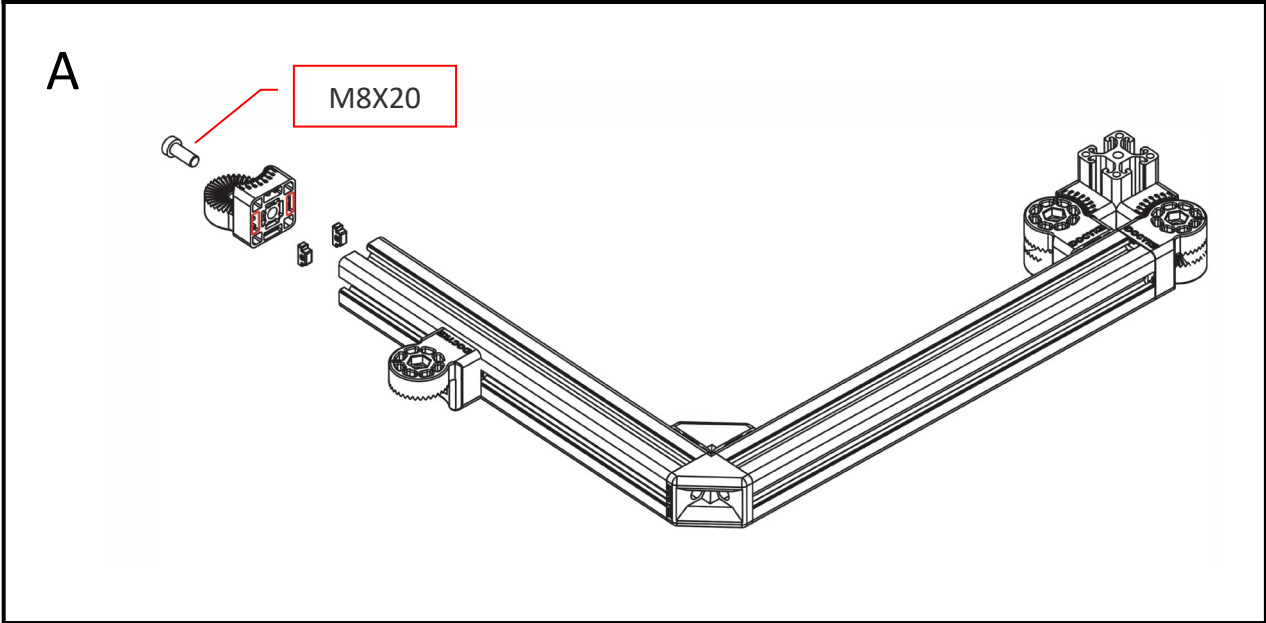
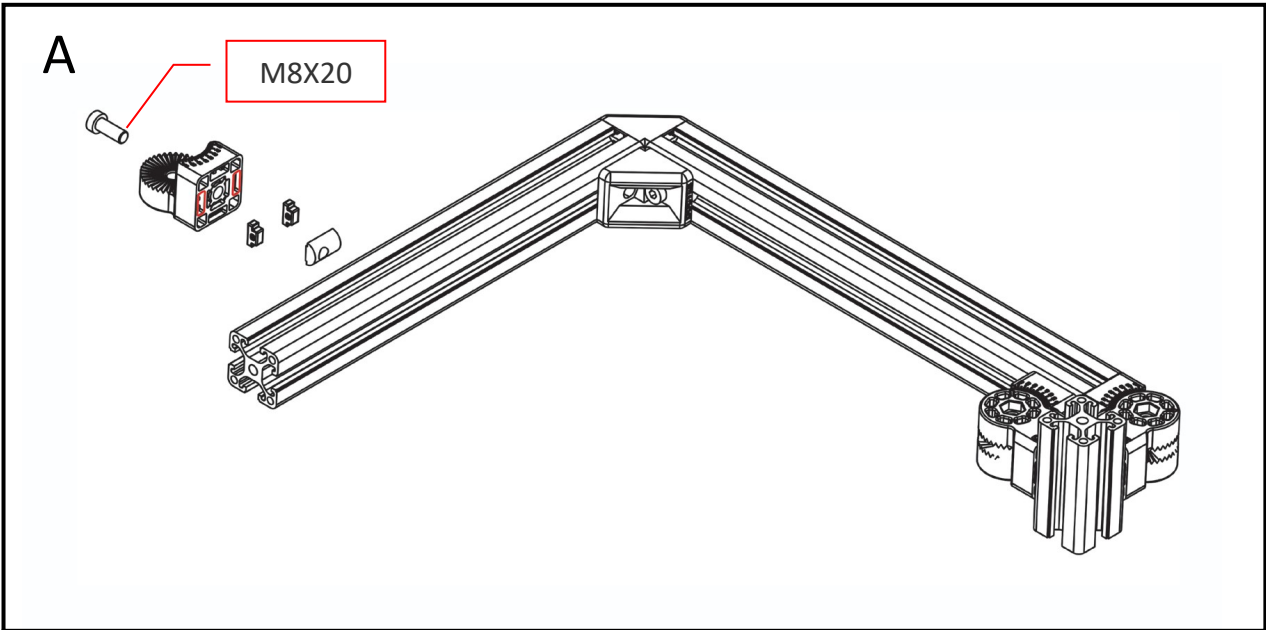

6

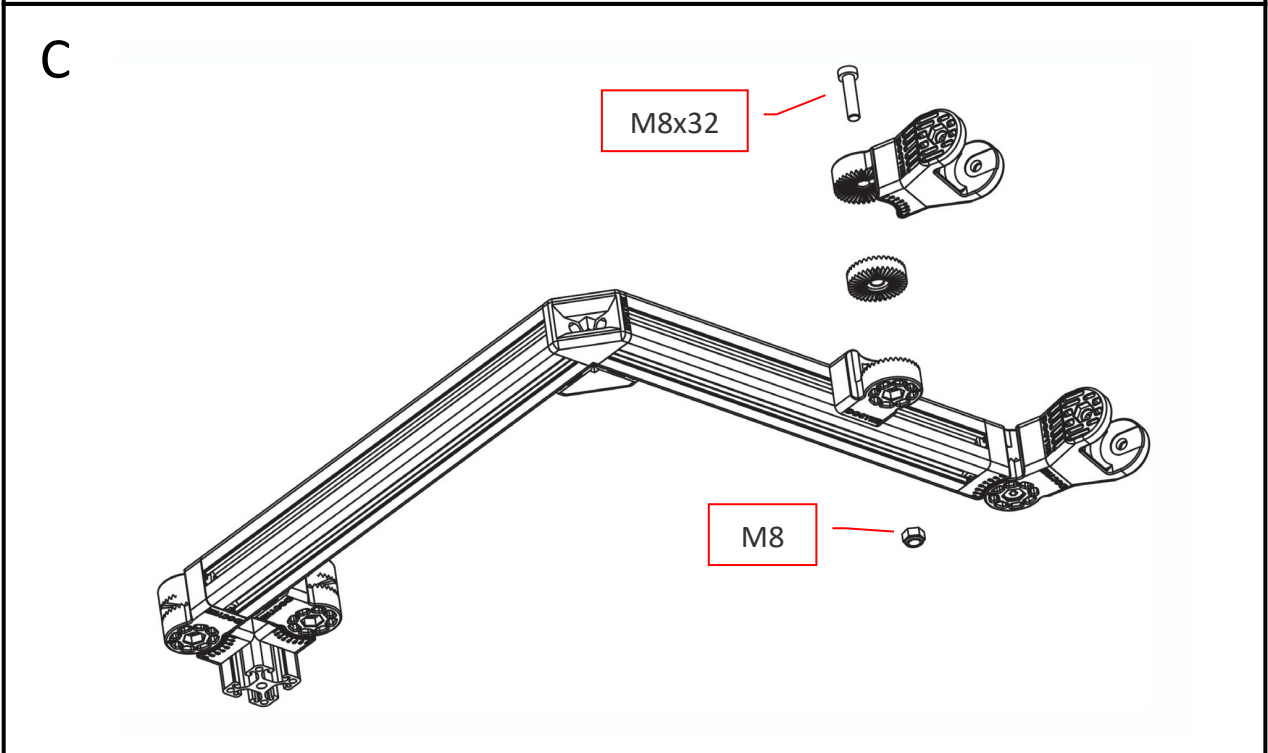
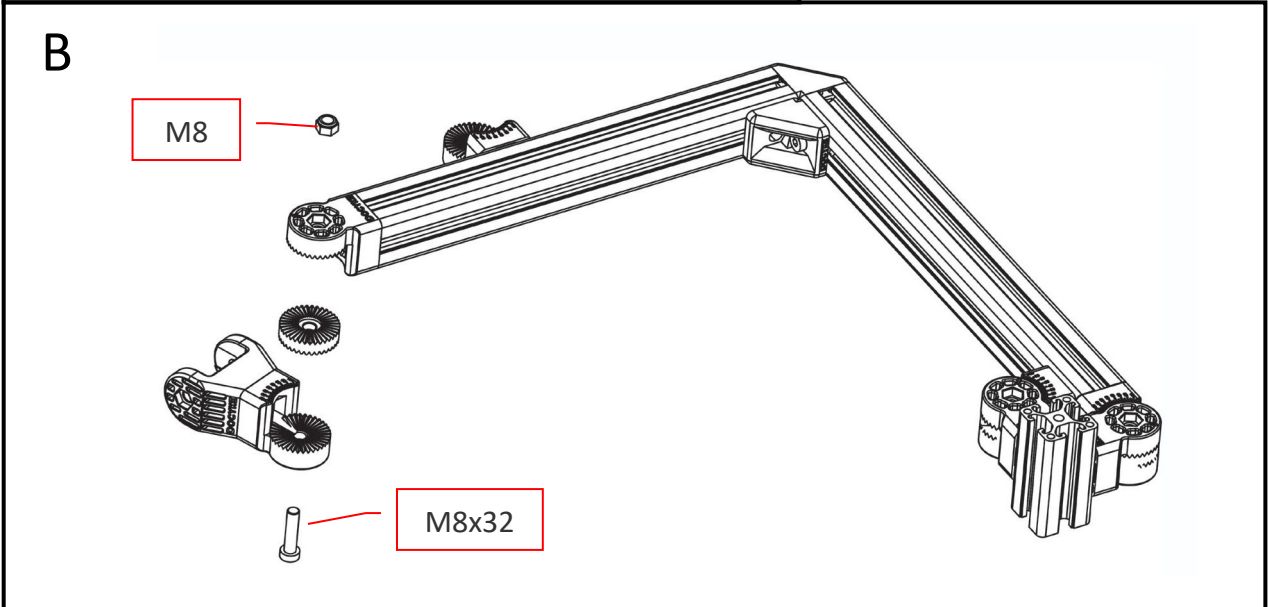
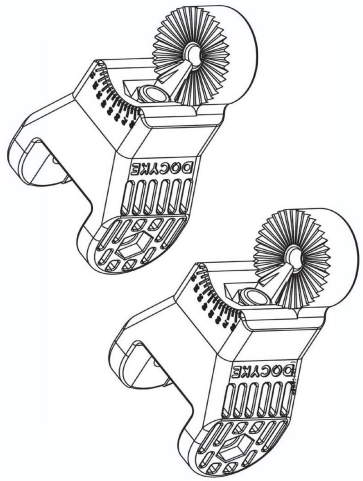
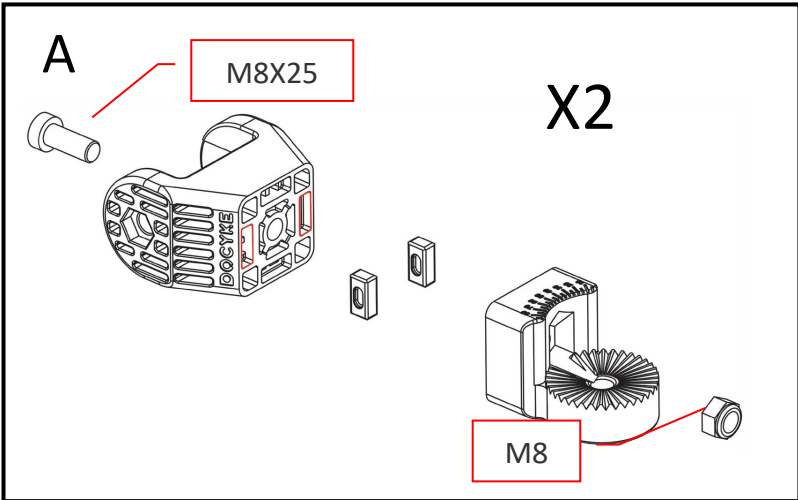

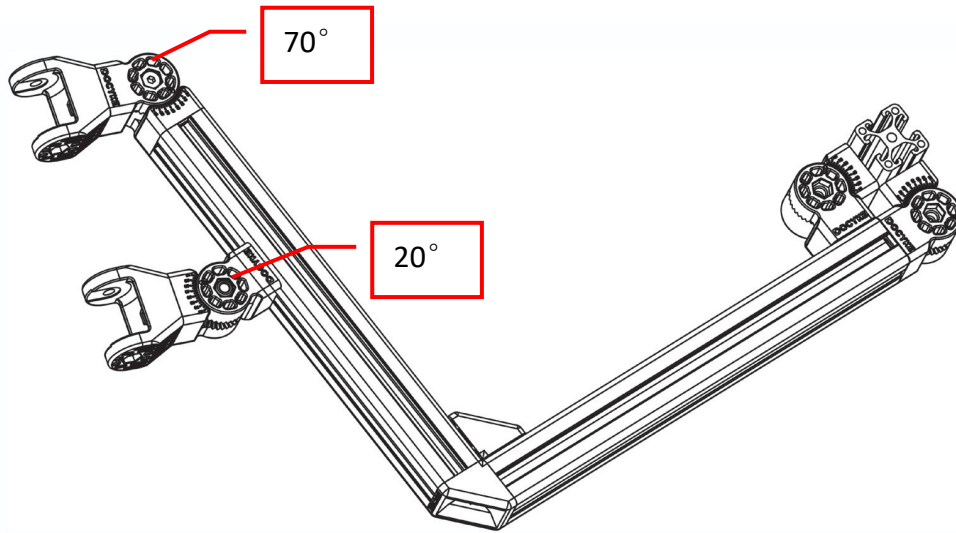

7

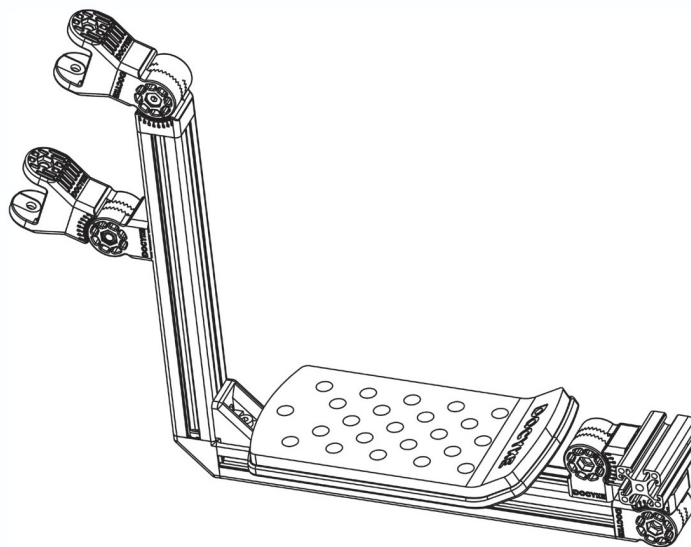
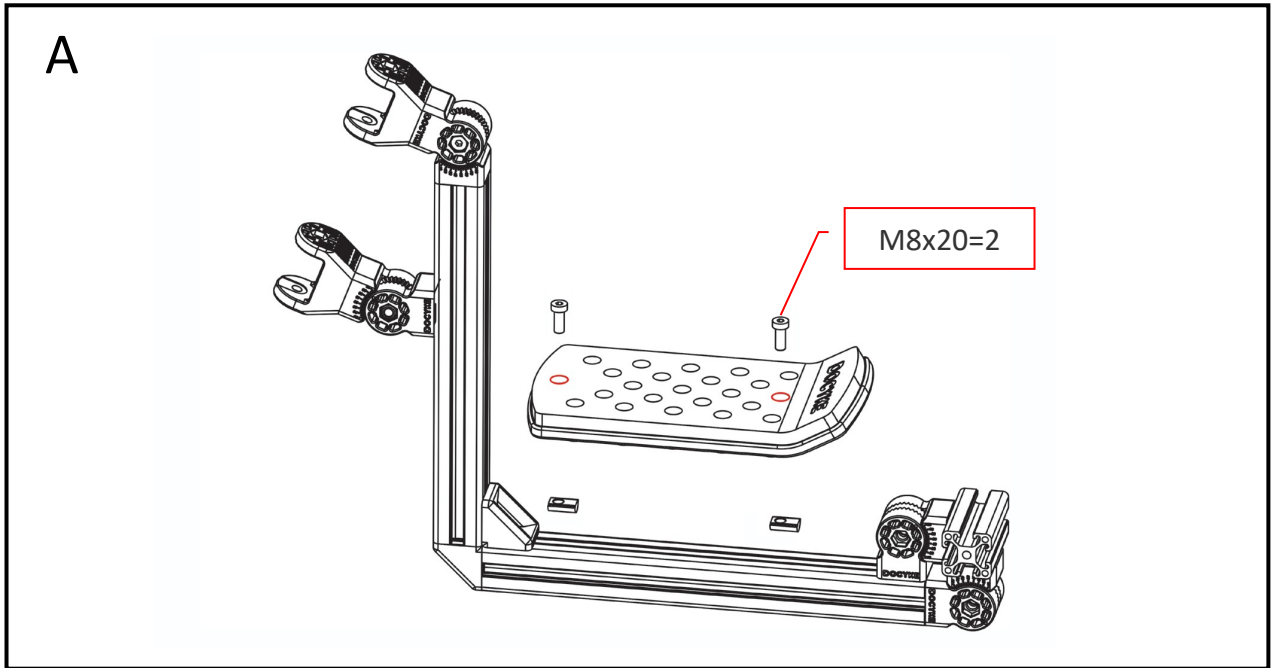

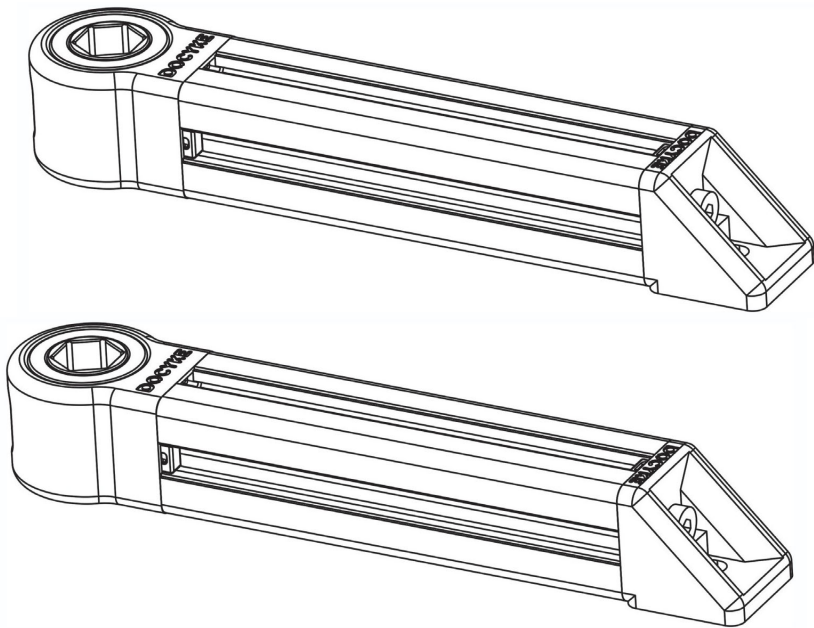
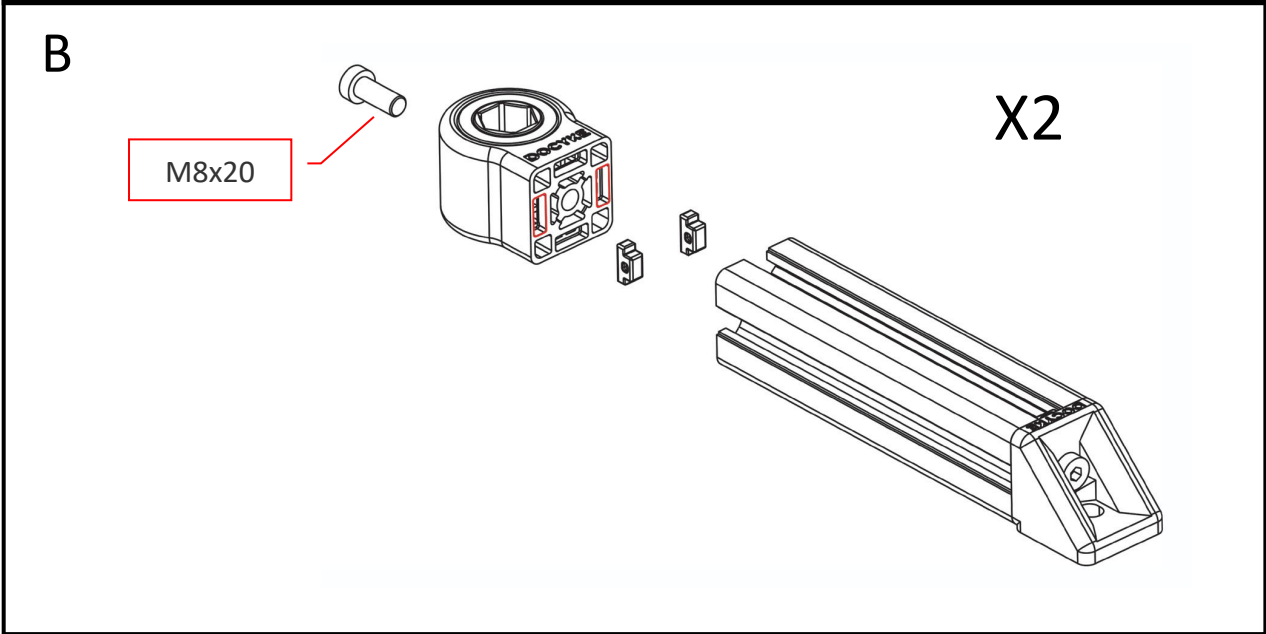
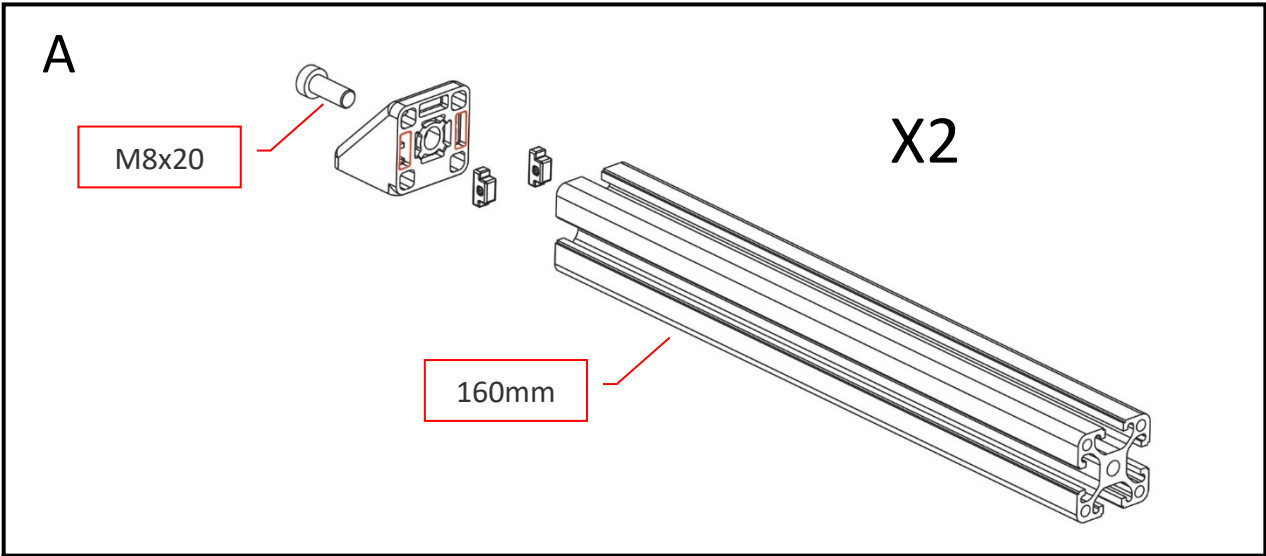

A

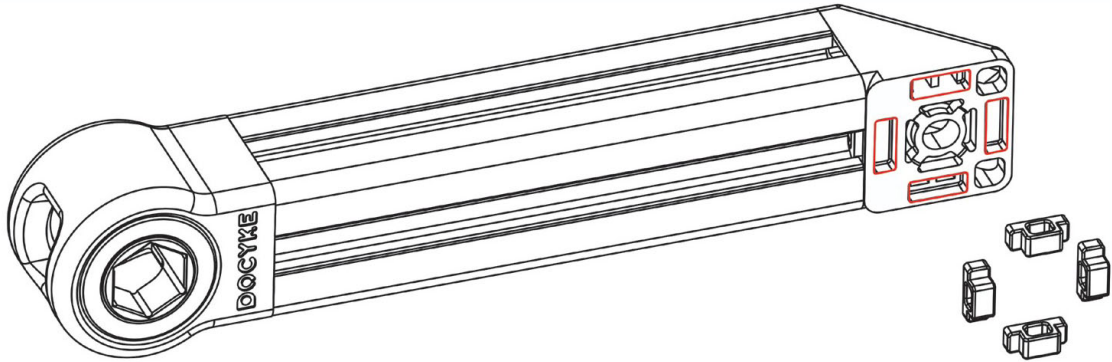

B

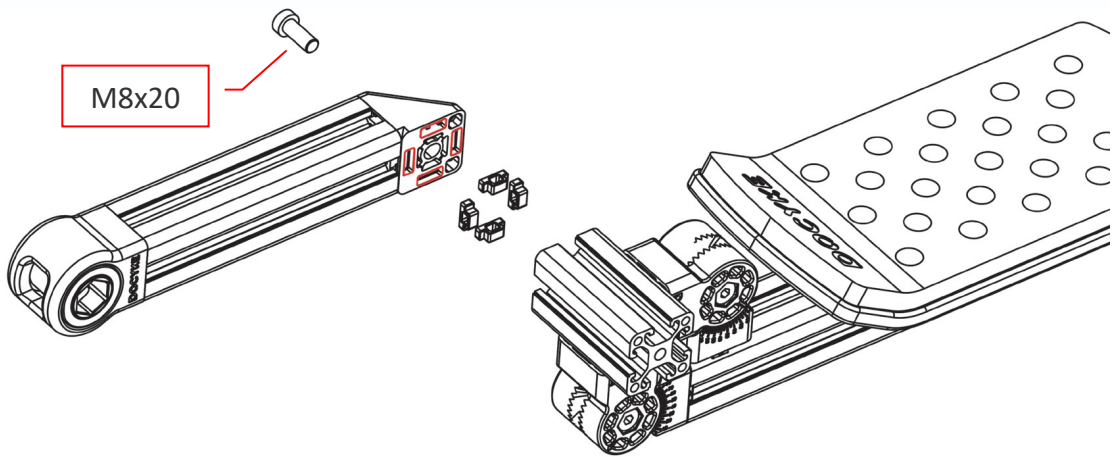

C

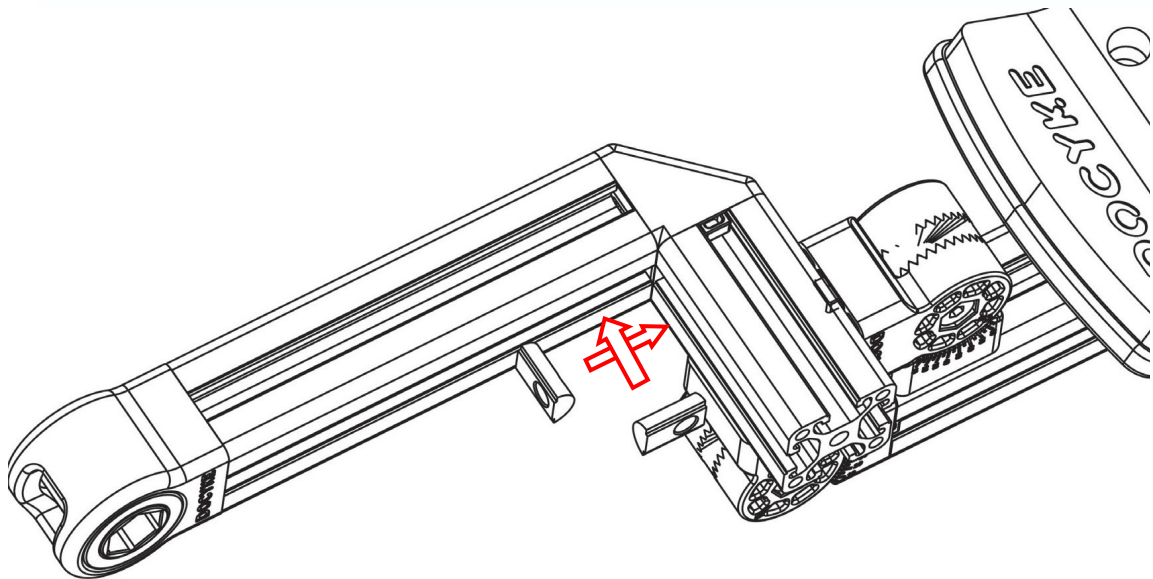

D

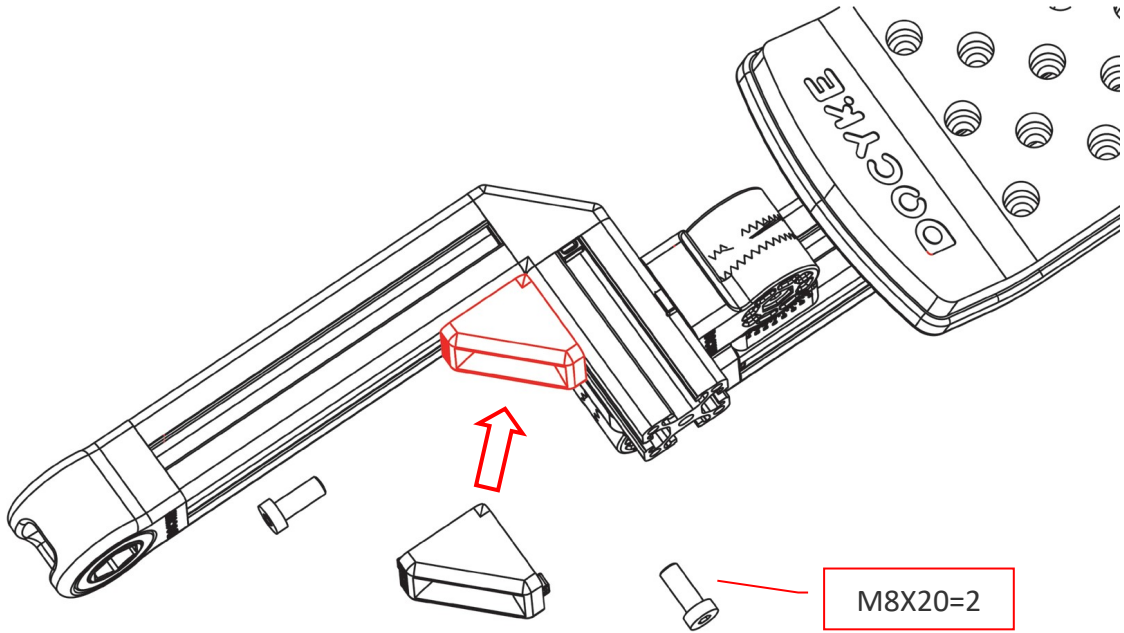

E

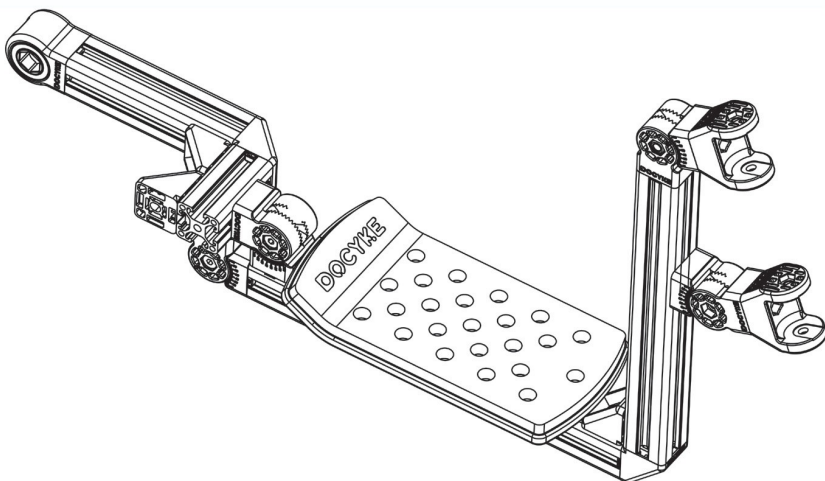
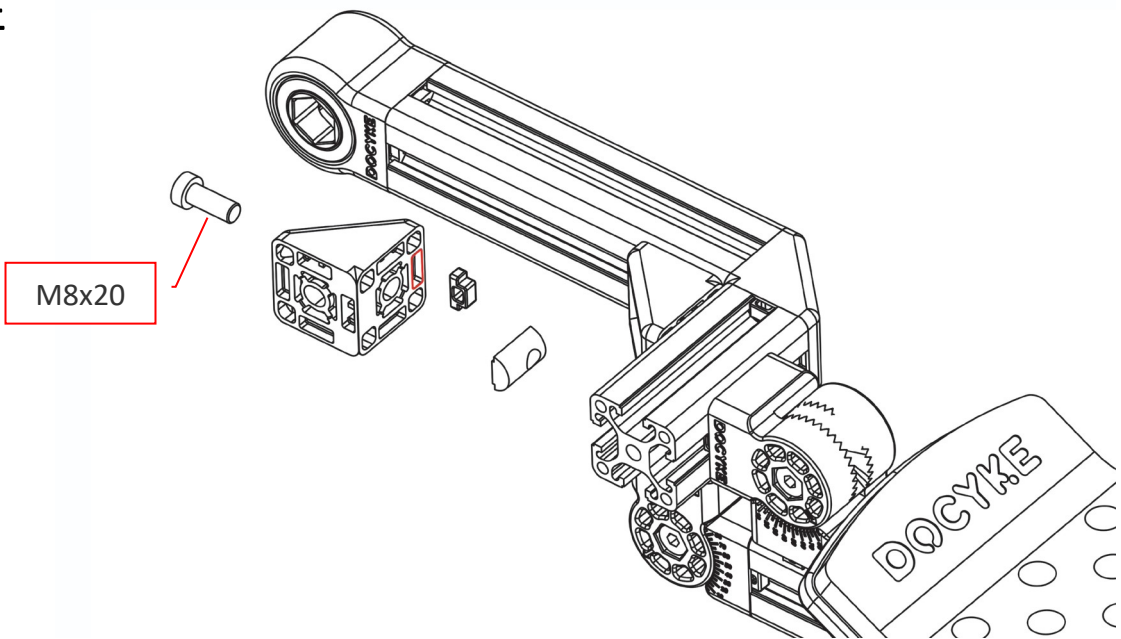

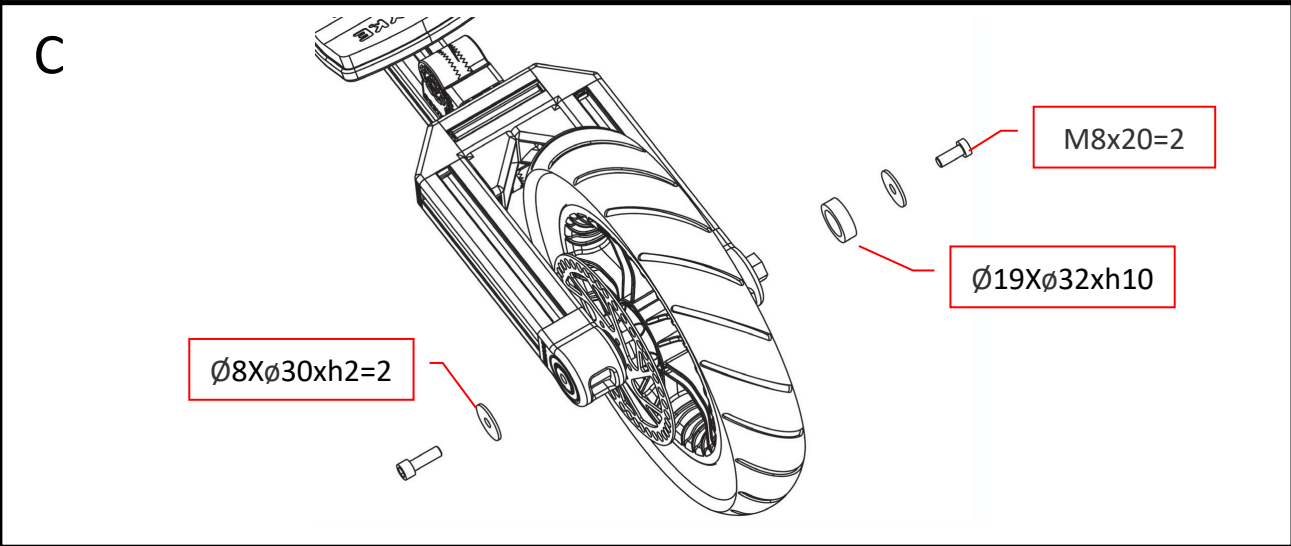
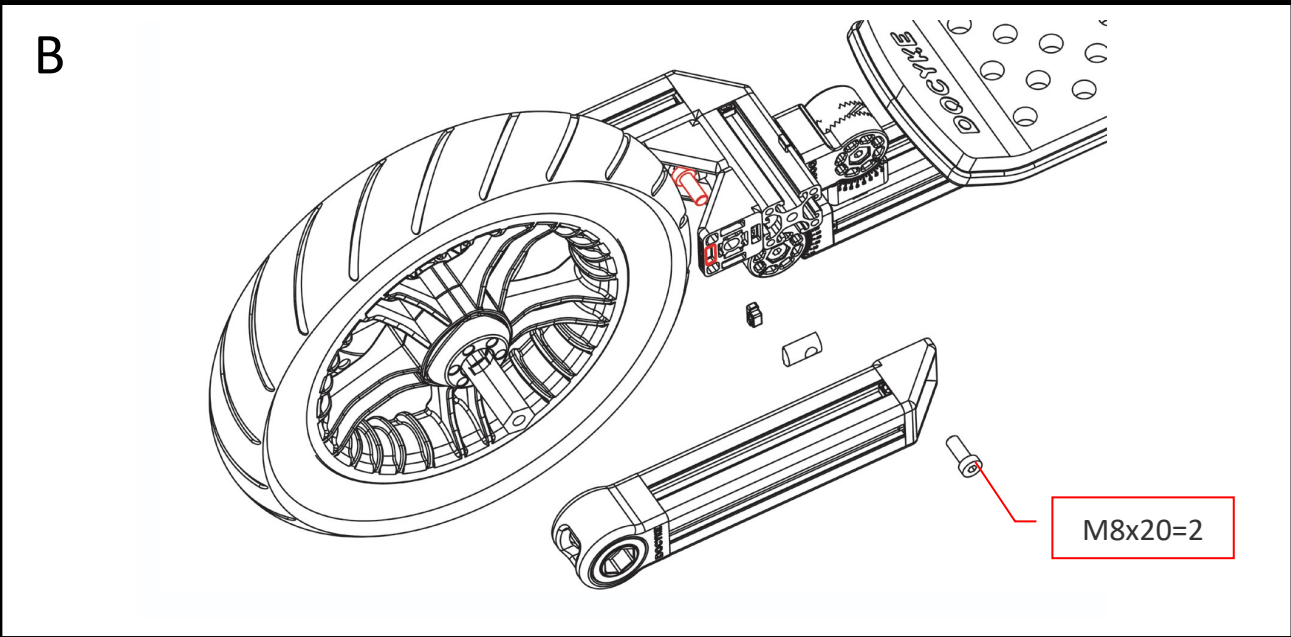
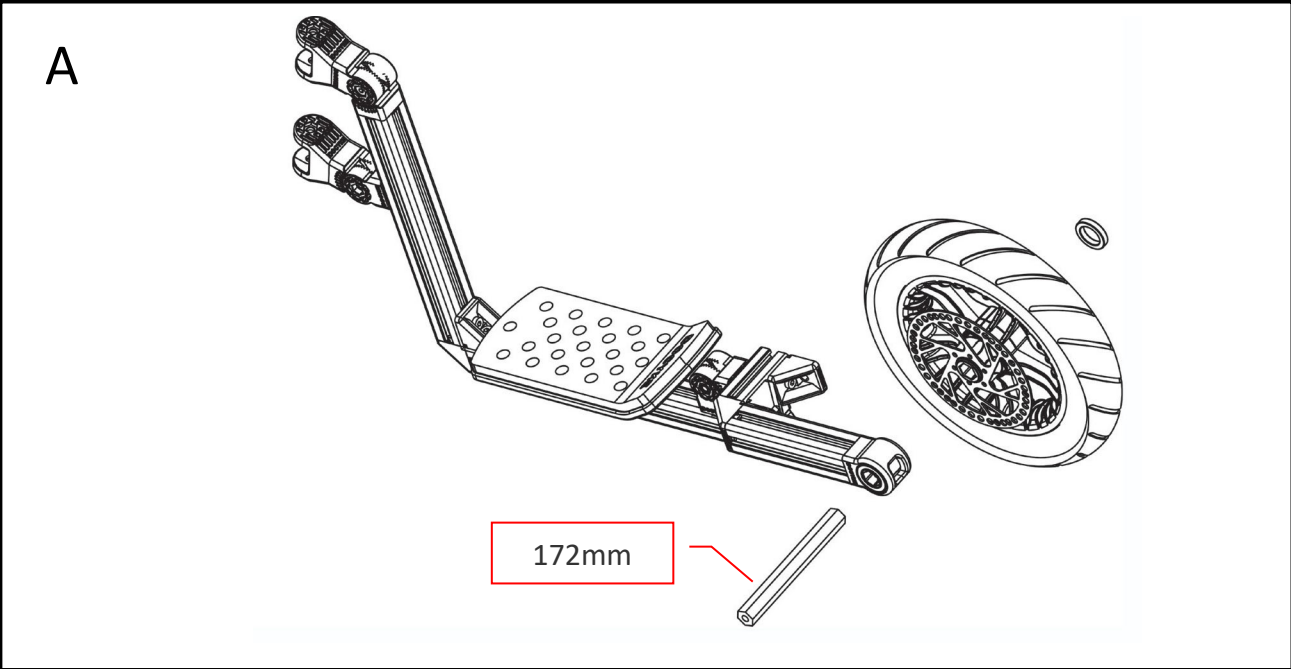

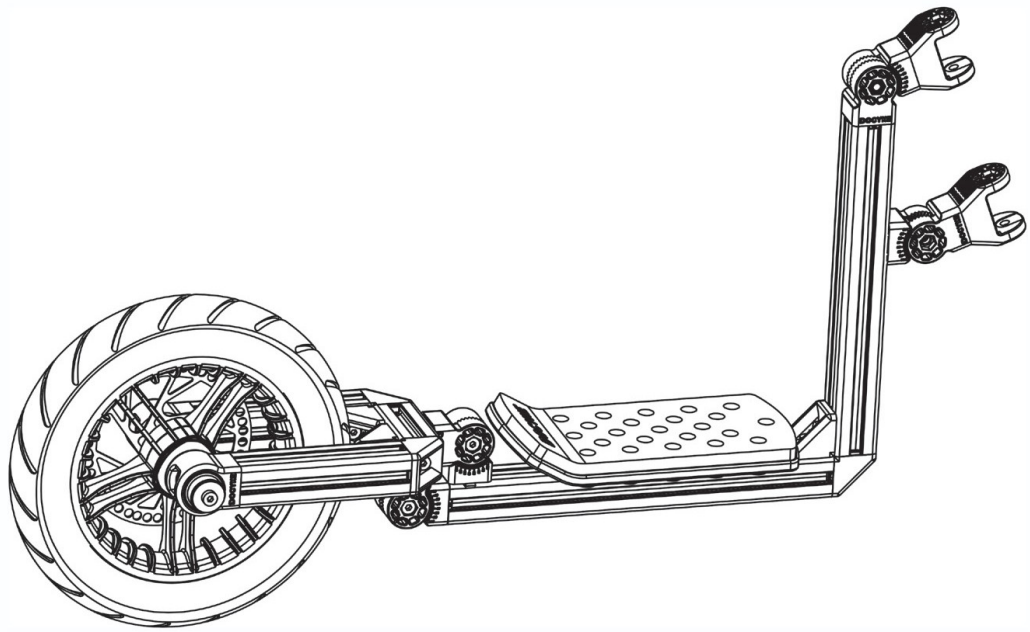

11

A

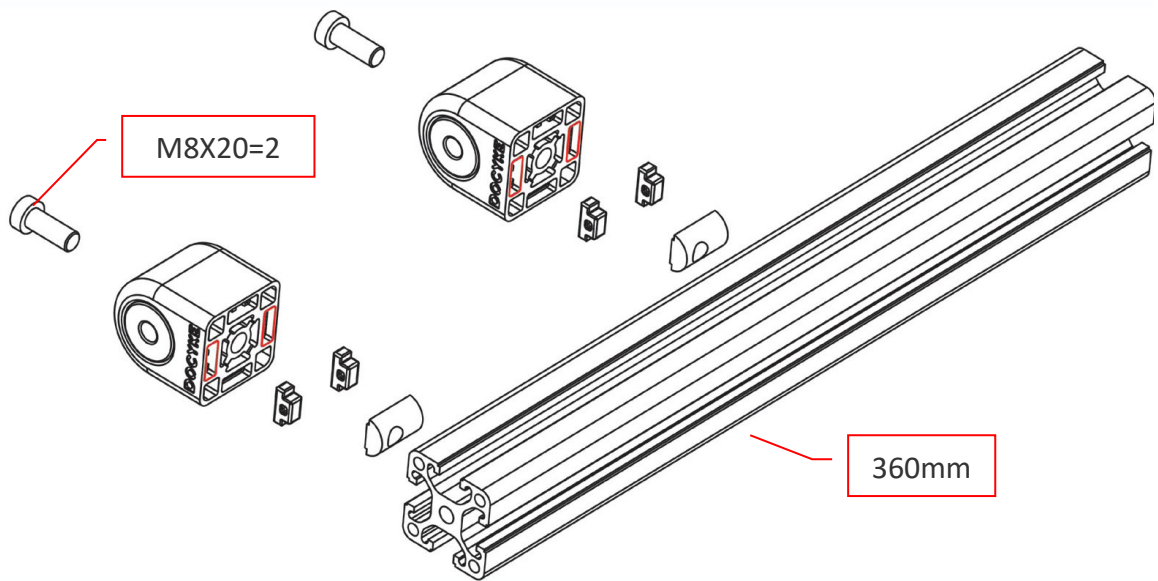

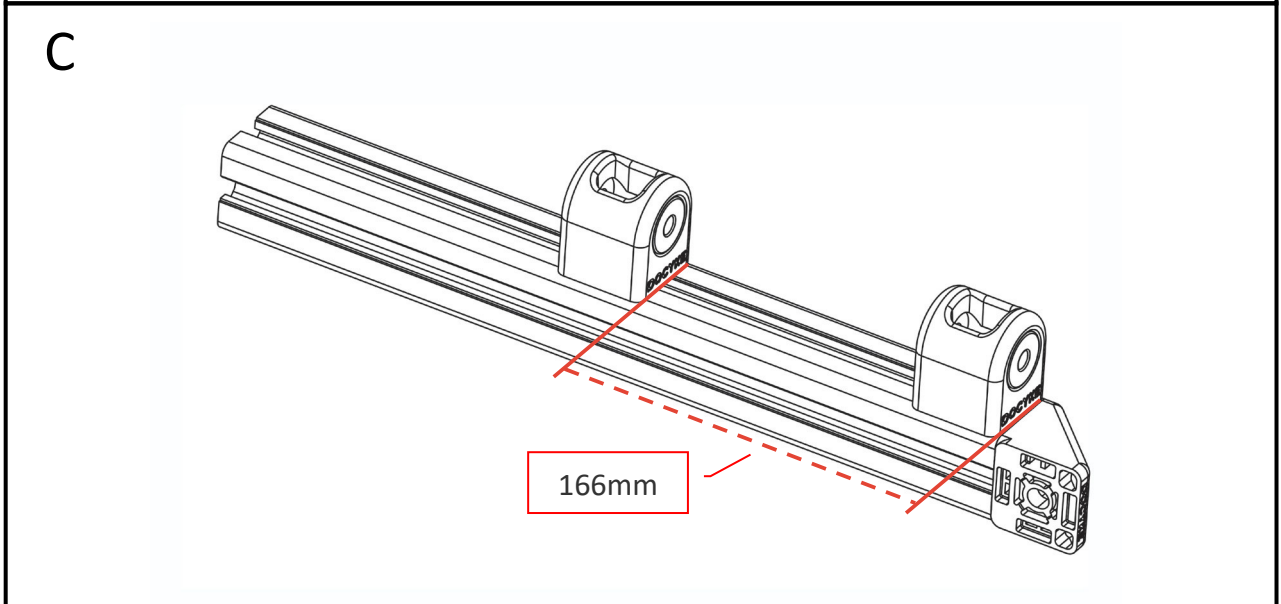
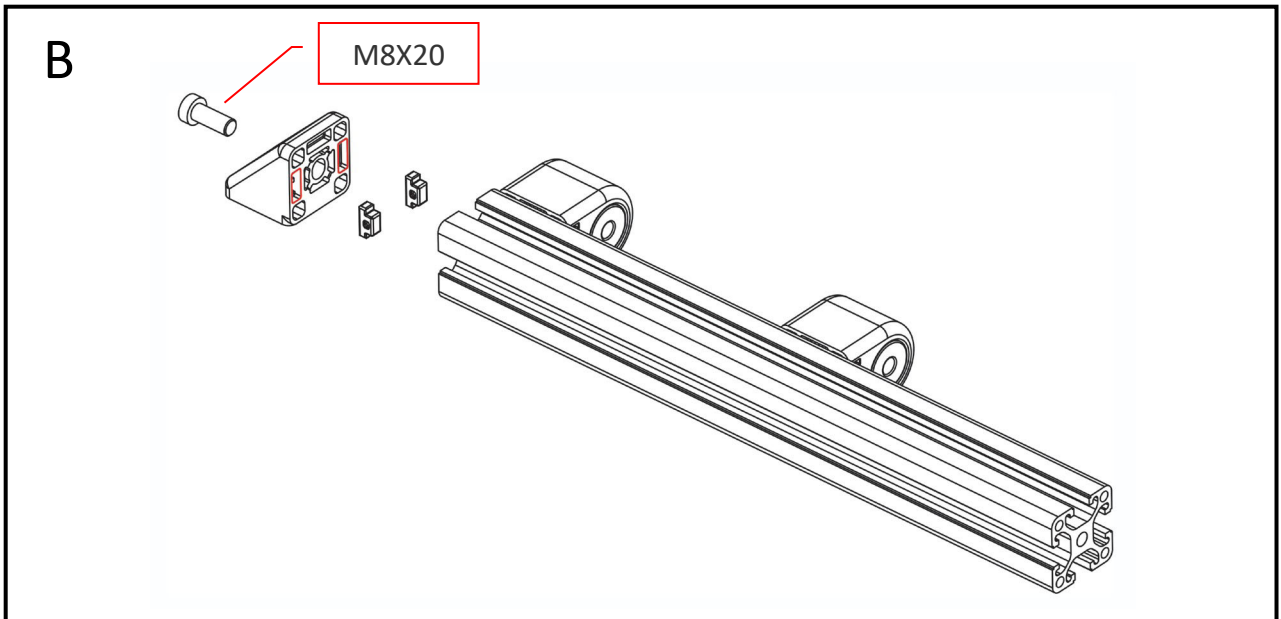

12

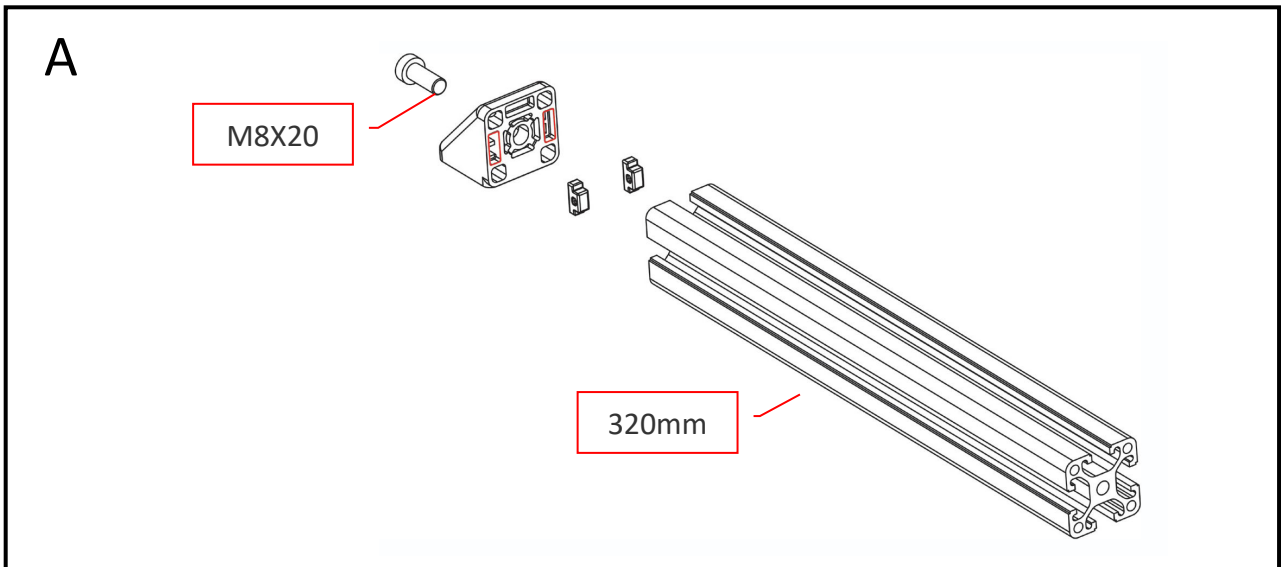

B

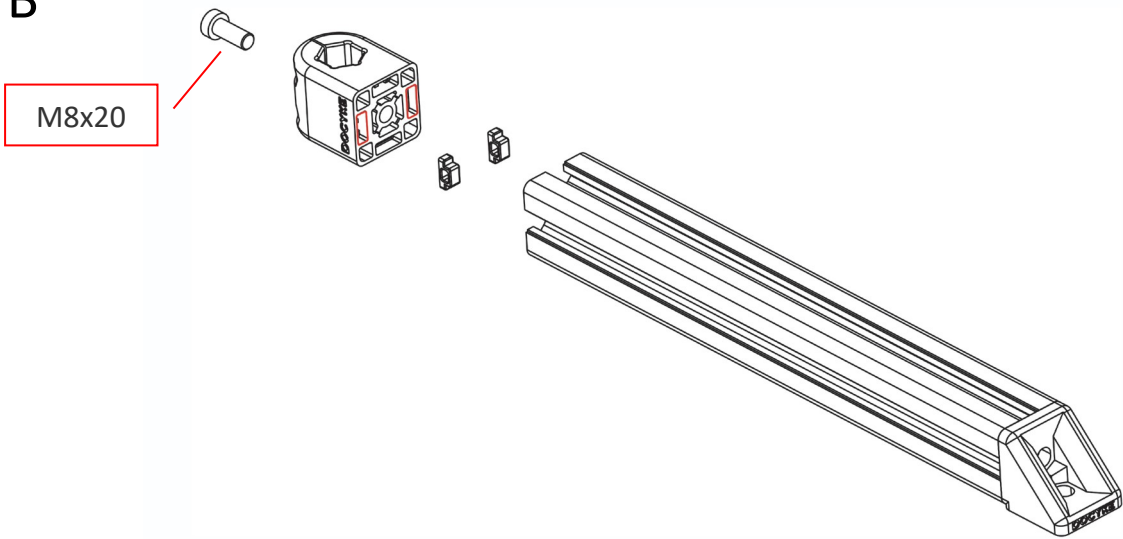

C

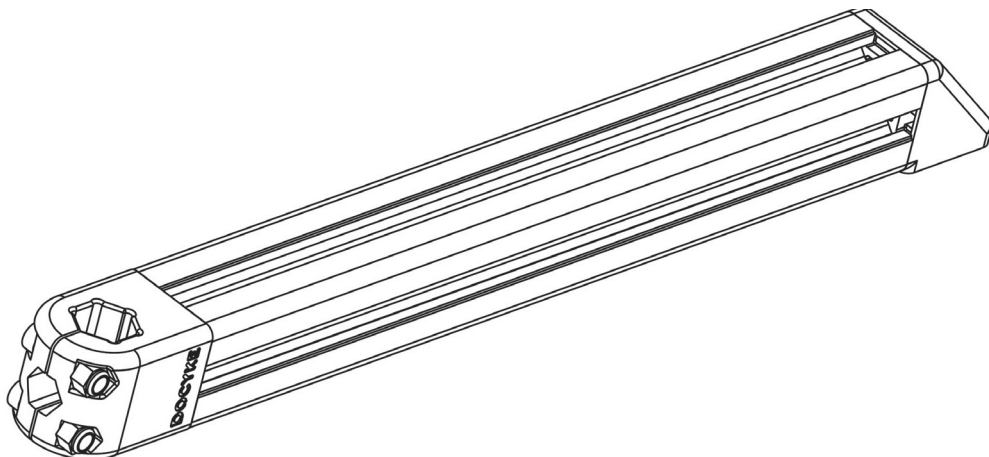
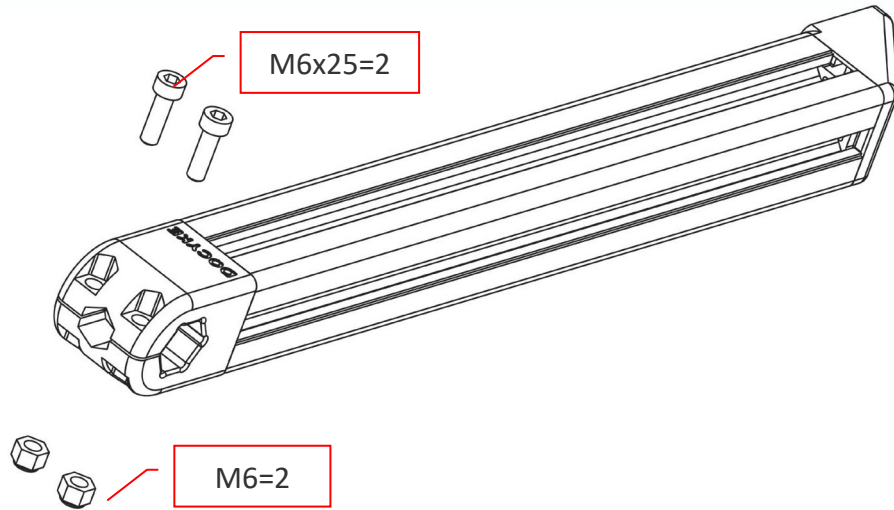

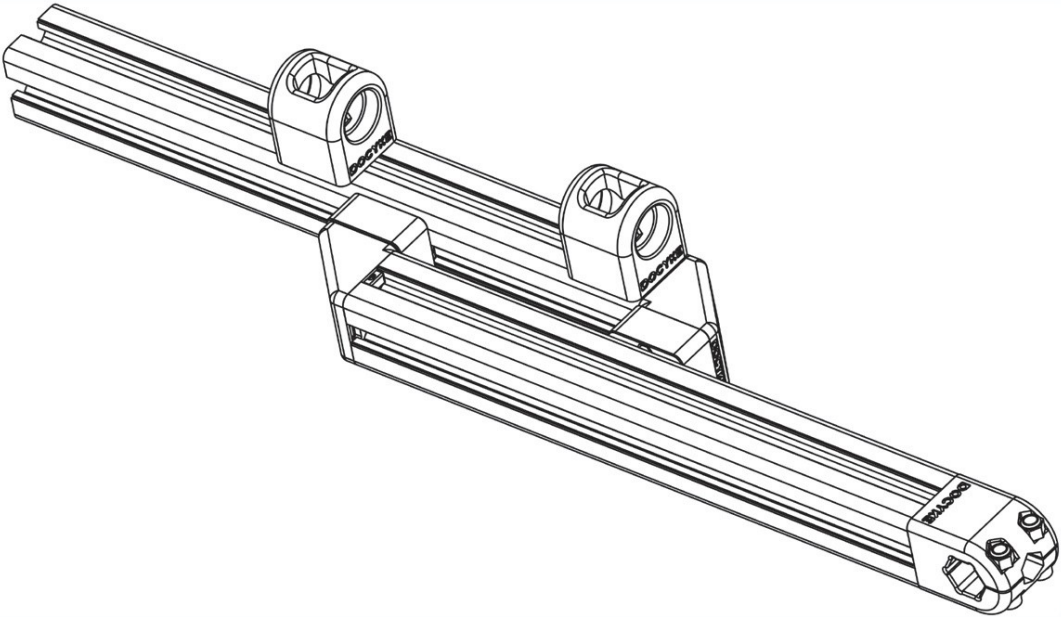
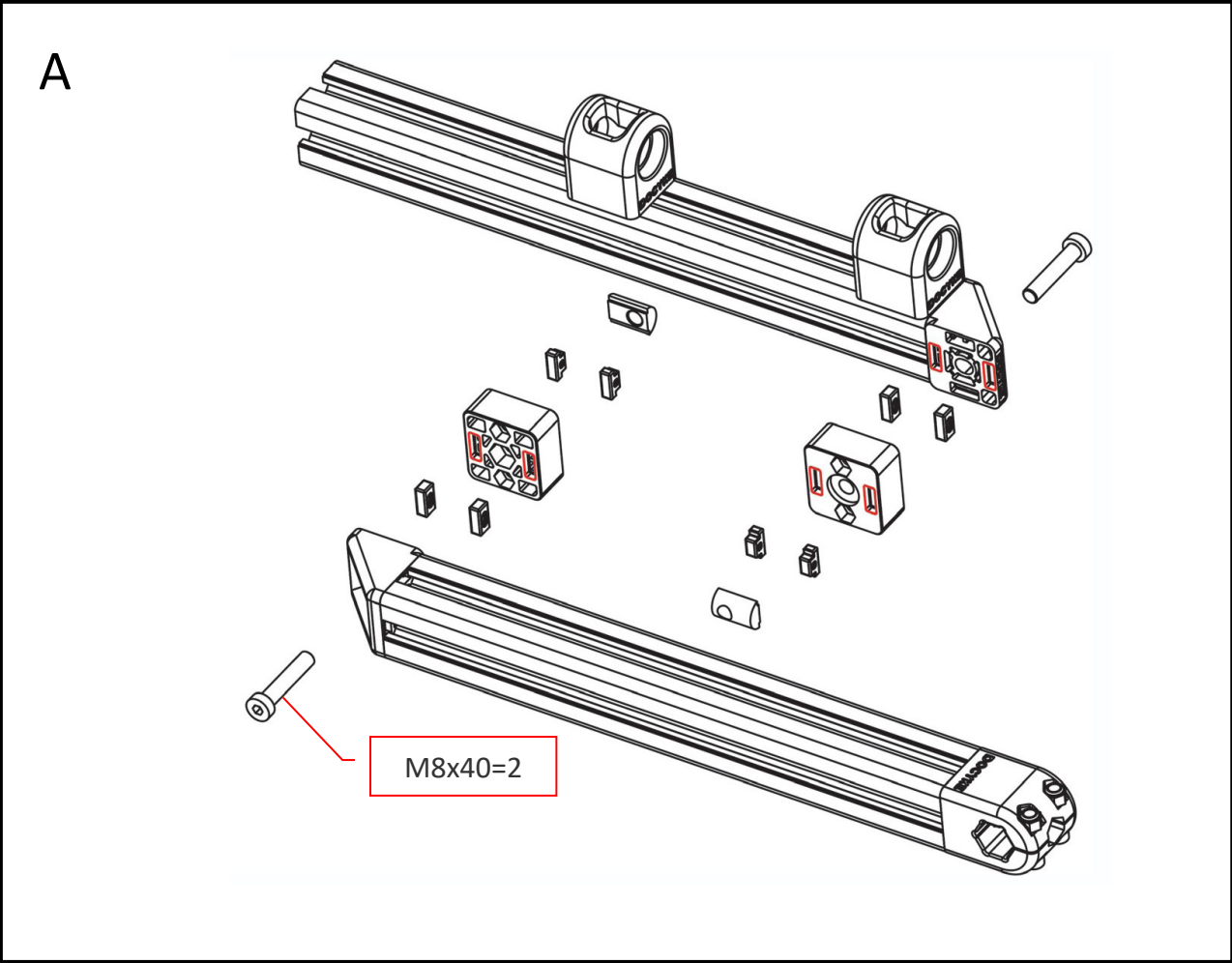

A

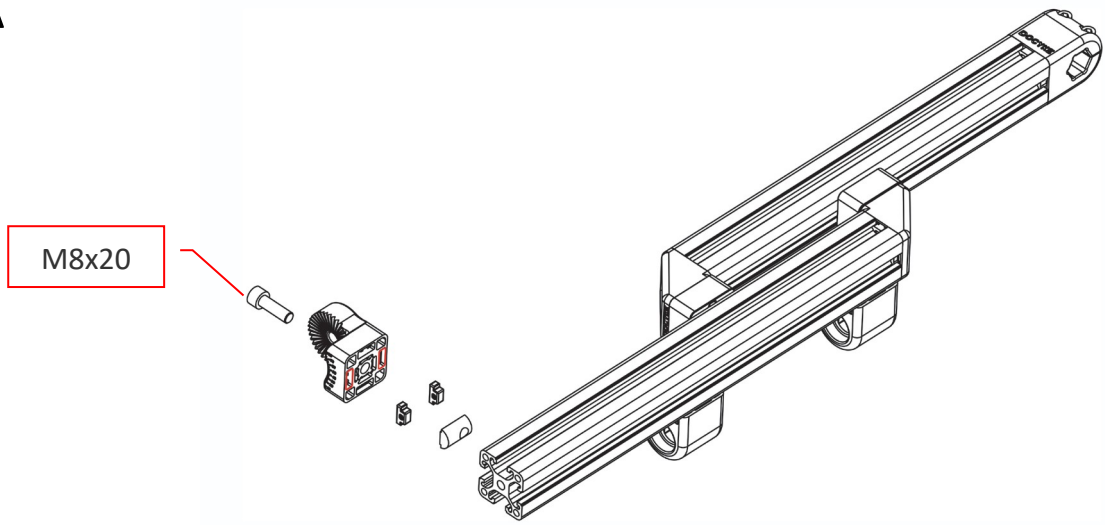

B

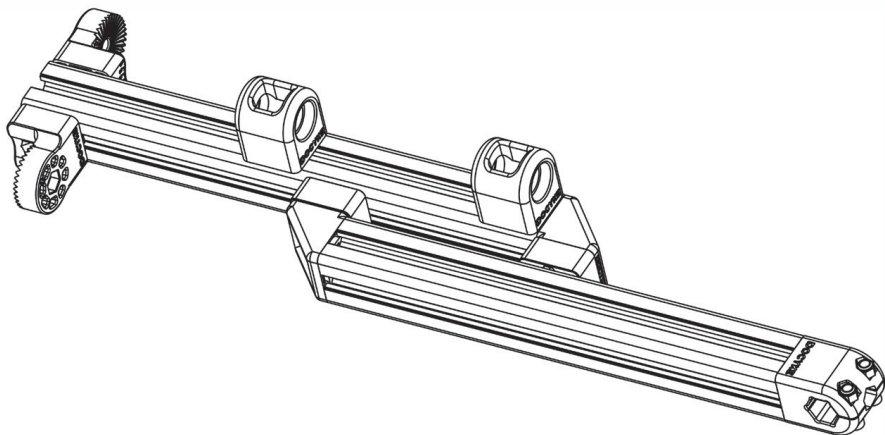
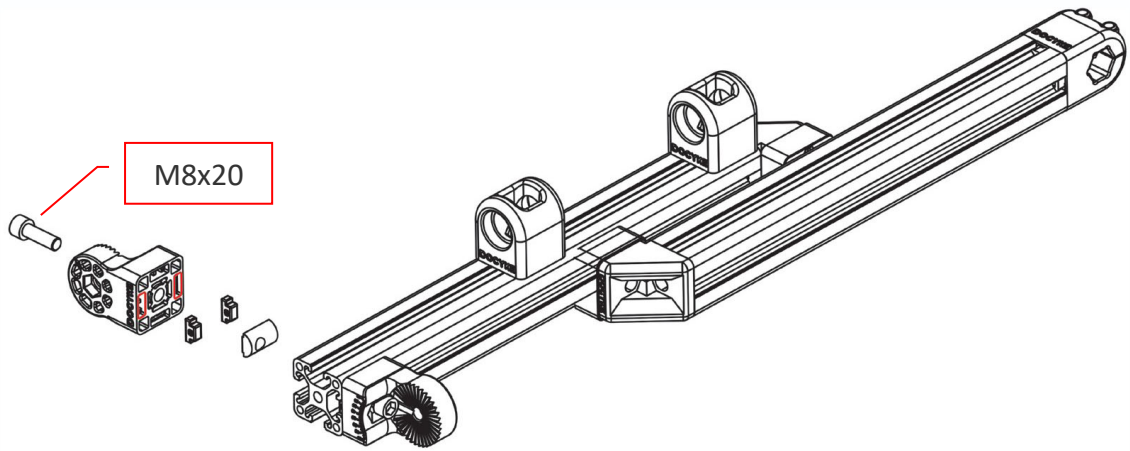

B

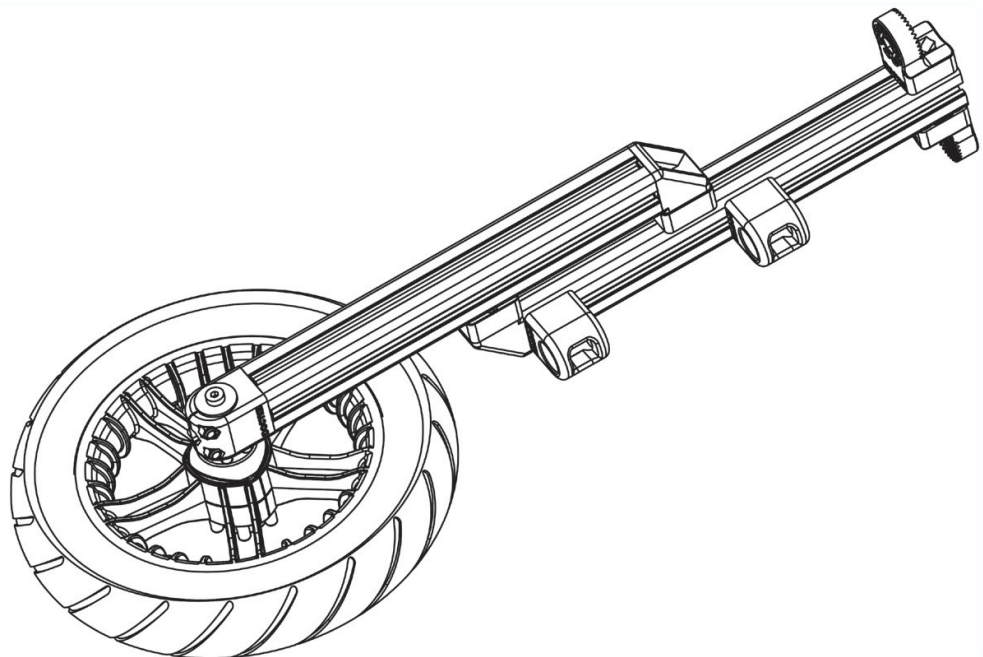
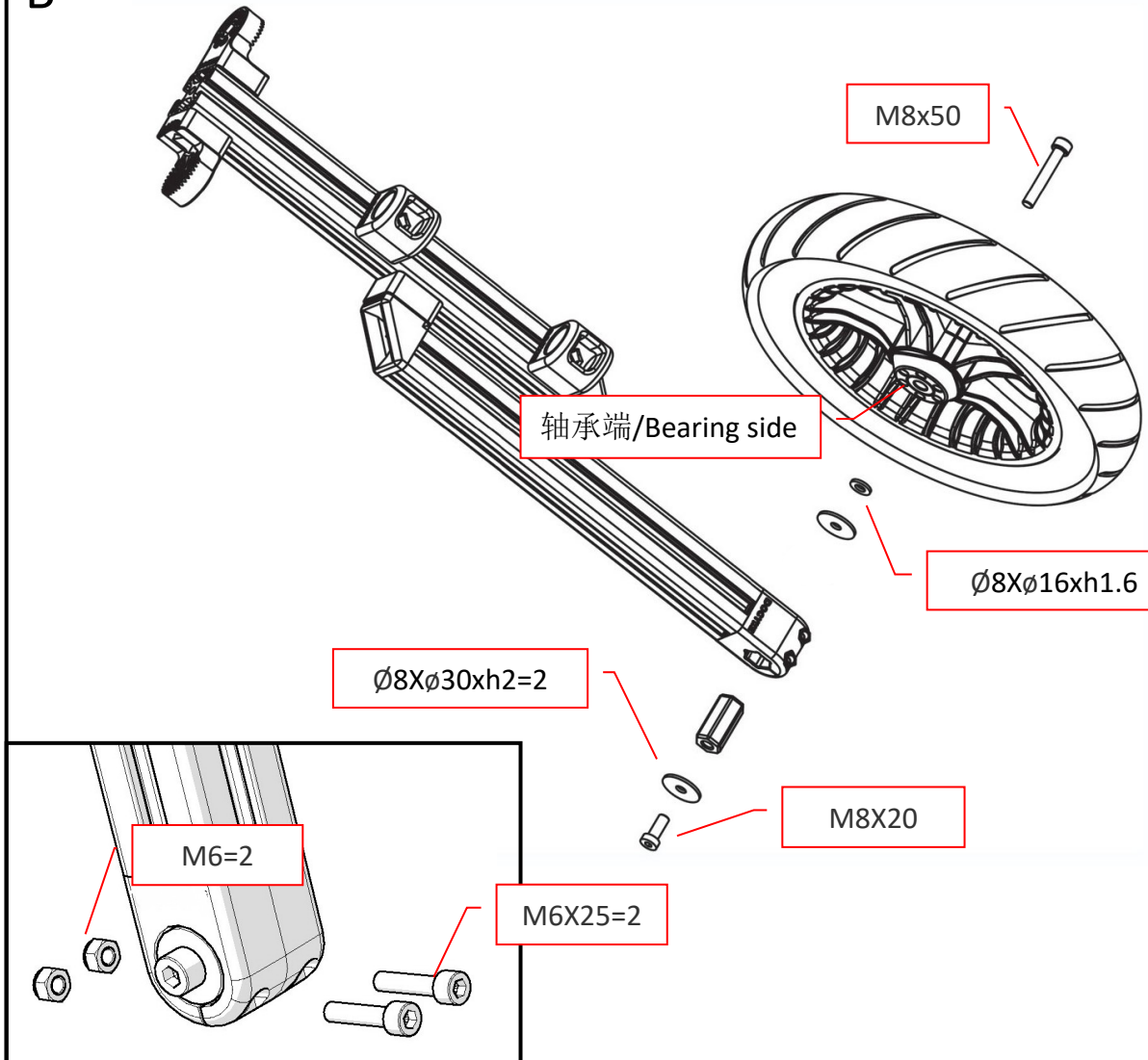

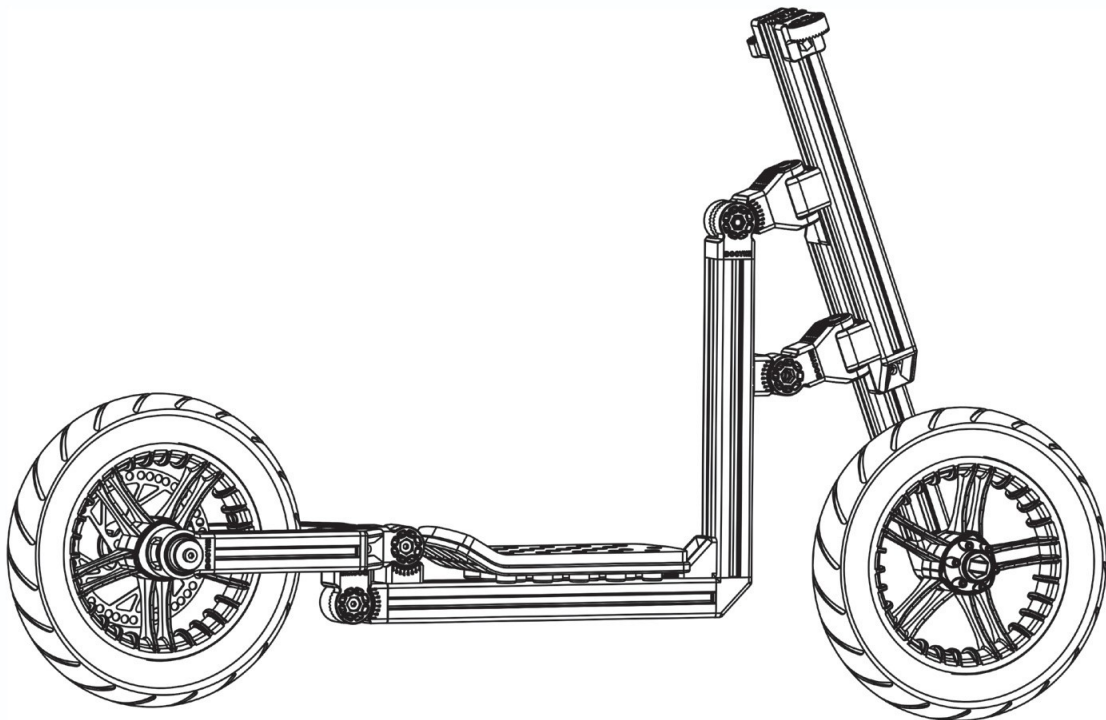
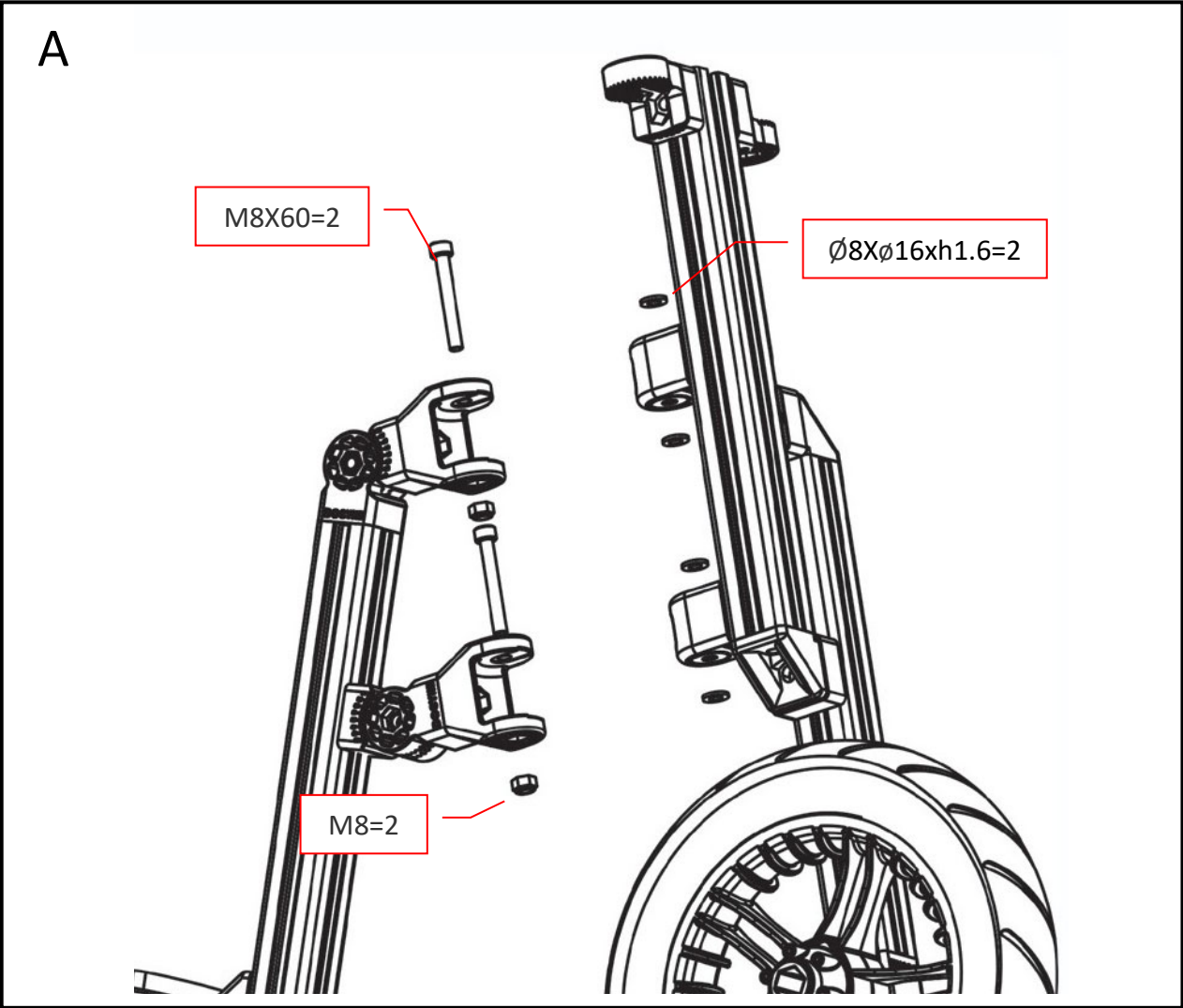

16

There are two different knurled discs.
 One for each corner ending in a 5(5-15-25-etc. degrees)
 One for each corner ending in a 10(0-10-20-etc. degrees)

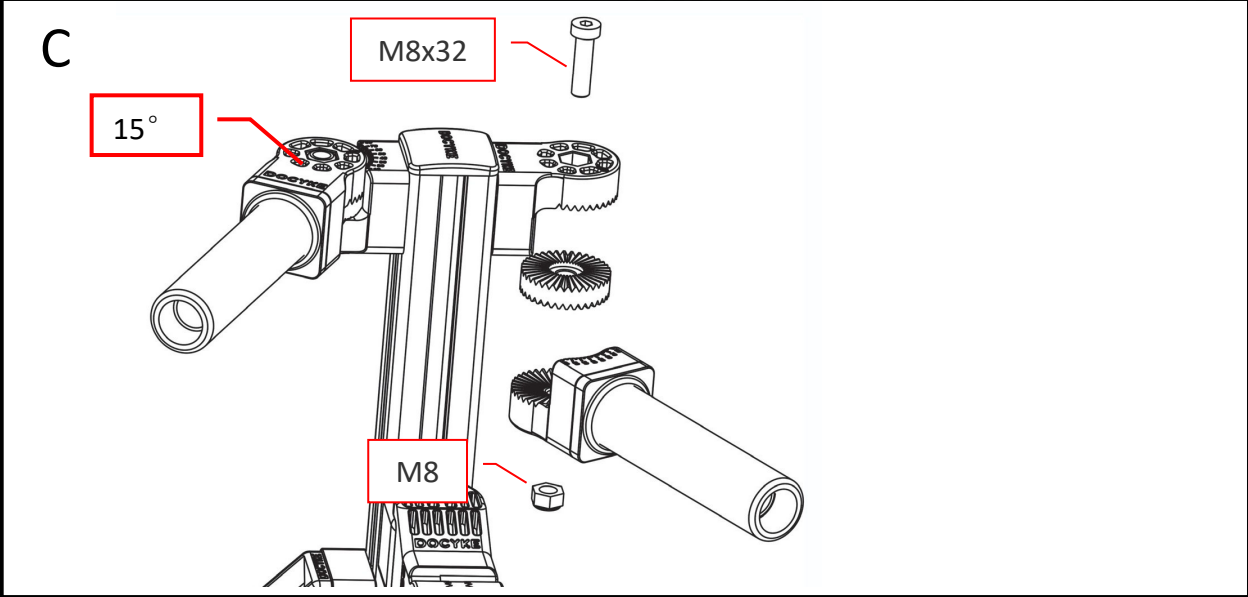
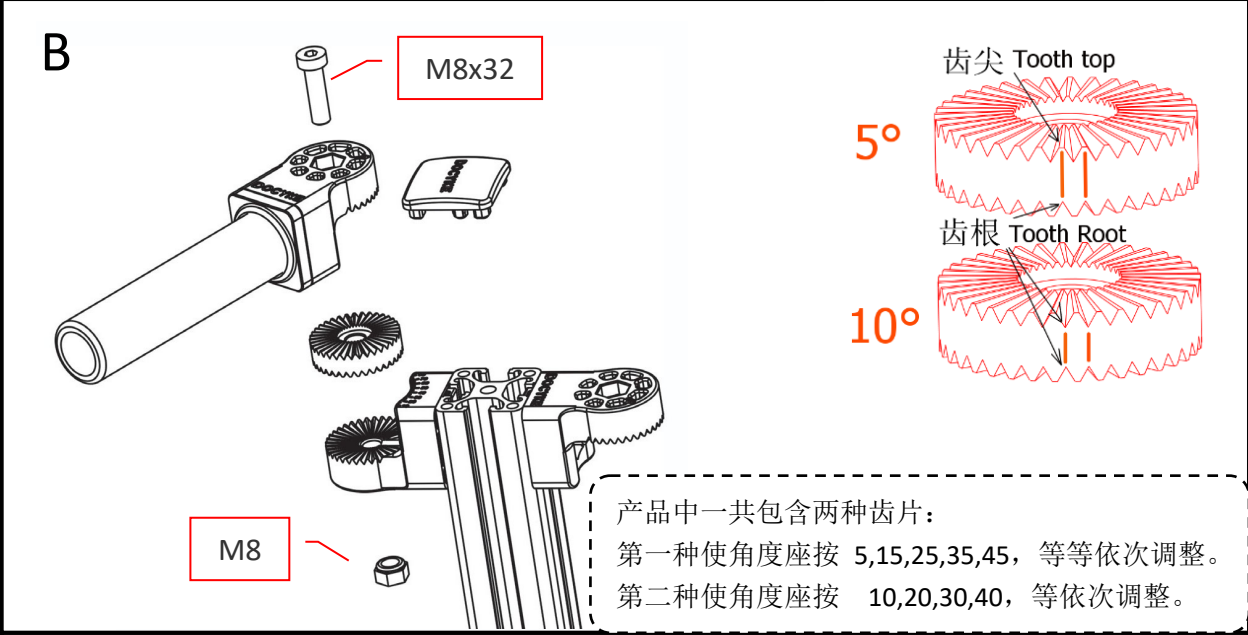
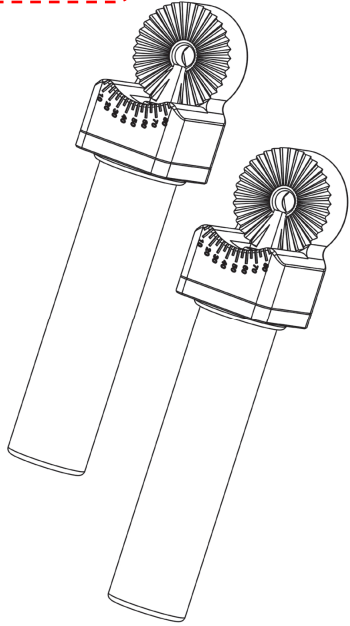
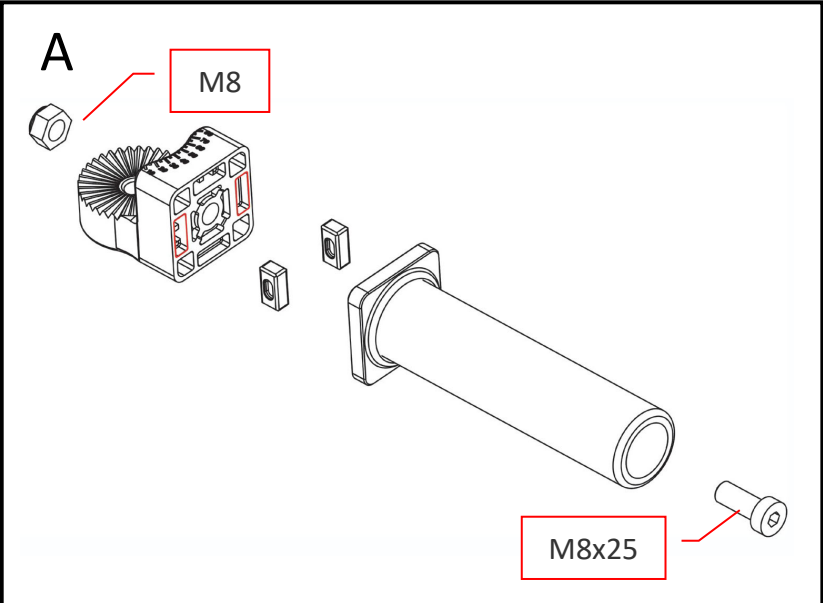

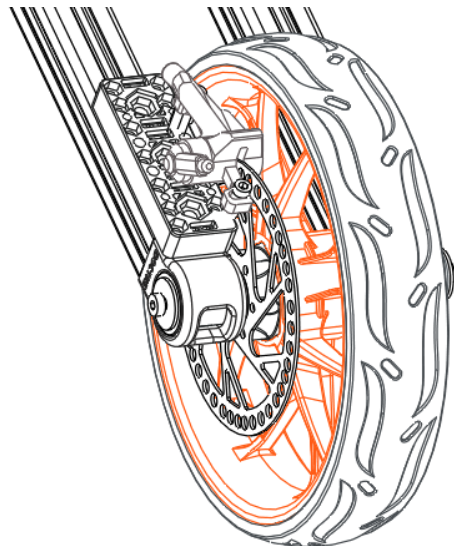
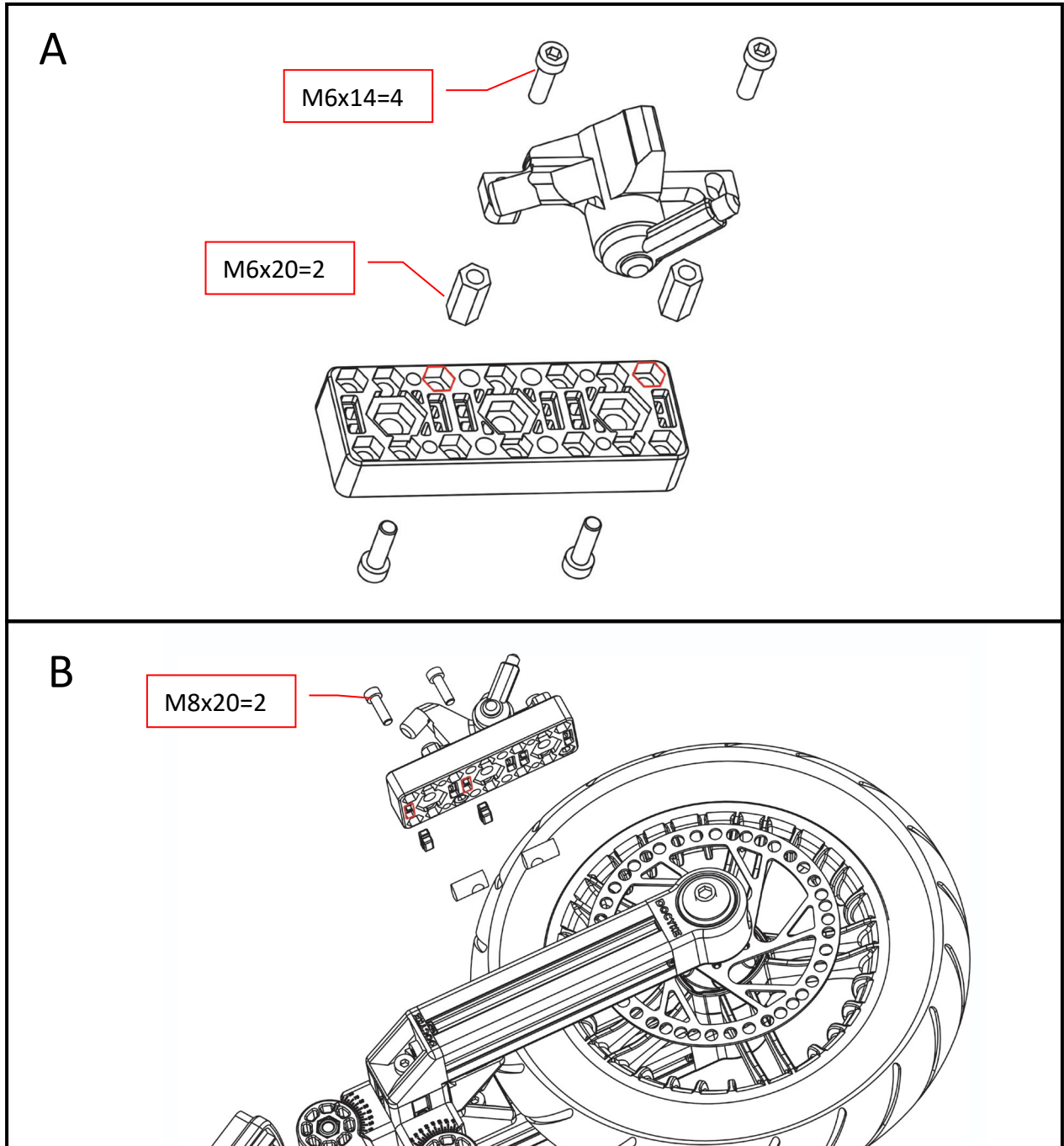

C

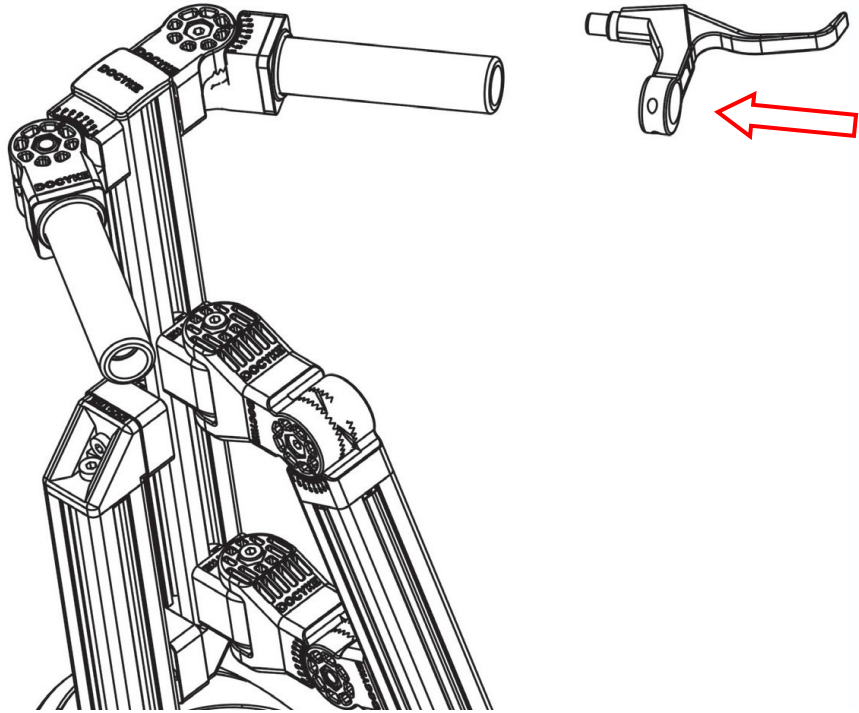

D

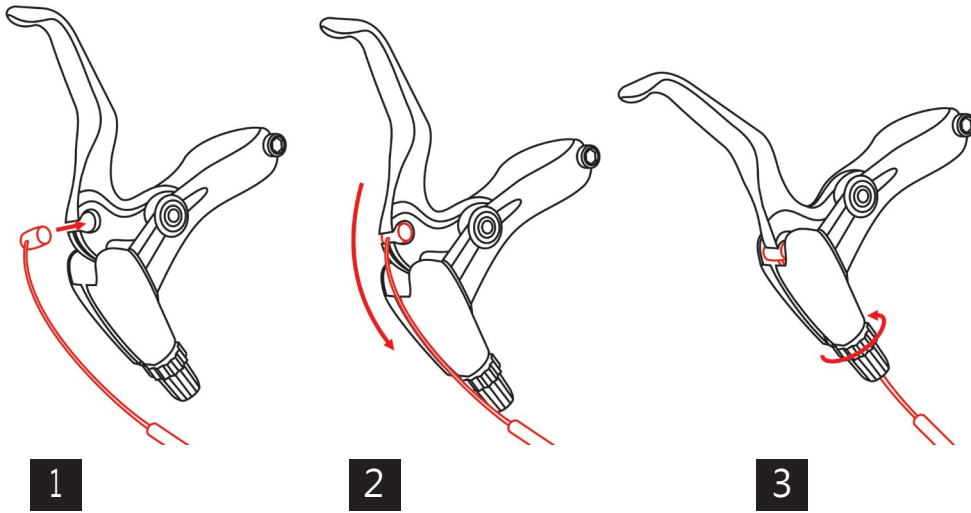

E

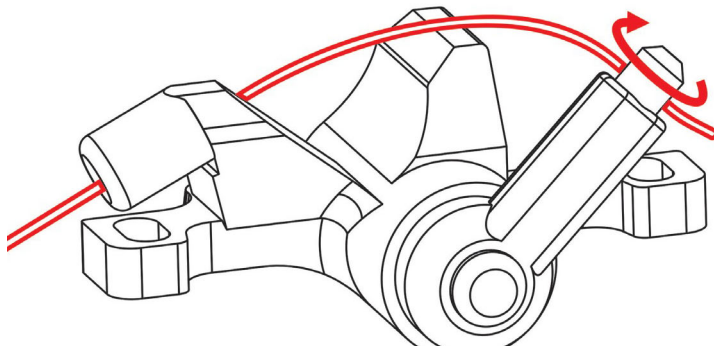

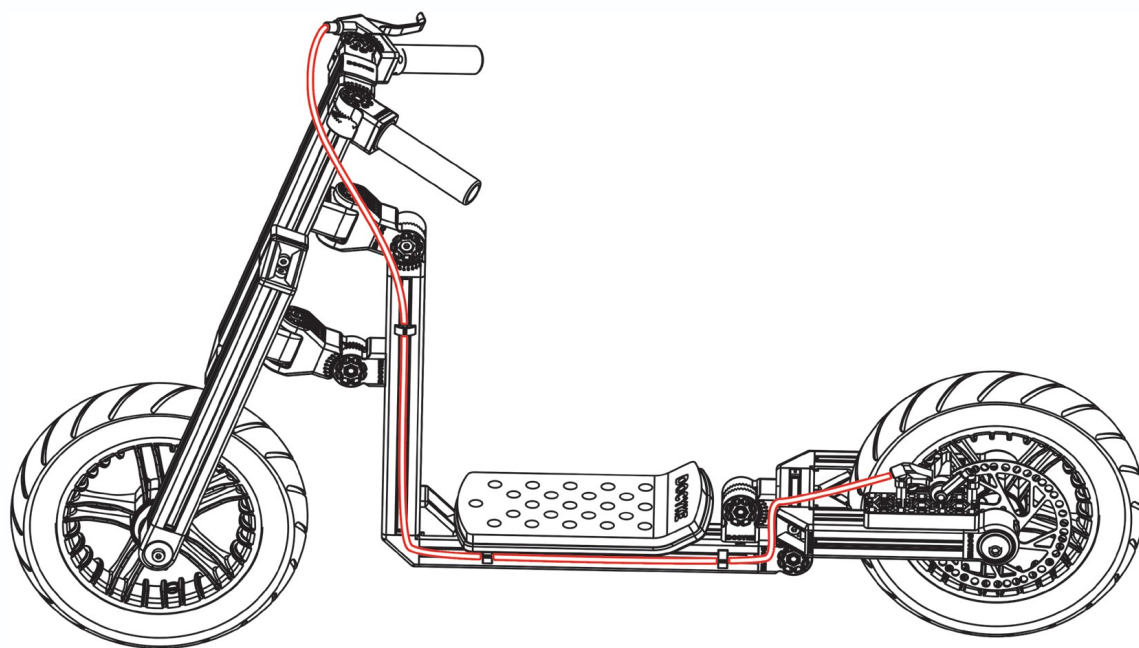
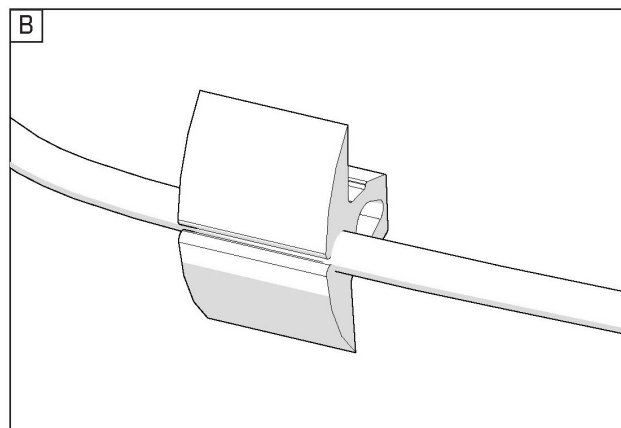
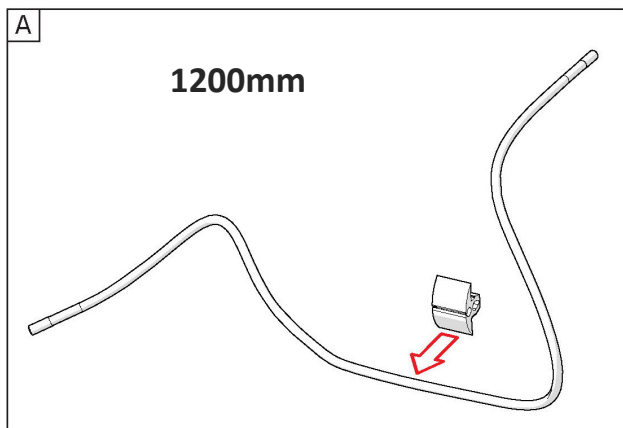

如果您有任何问题，或者更好，更酷的创意，欢迎联系我们。

If you have any questions or better ideas, welcome to contact us.

do@docyke.com