

L-07

CONSTRUCTION MANUAL

DOCYKE



安装时间/Time to build: 120 min

最大载重/Max weight: 30Kg

DOCYKE

多可

在您构建玩具前请先阅读下列内容，以保证儿童的安全并防止玩具损坏,更多说明请到我们的官方网站进行下载：www.docyke.com

Before you start constructing and use our product, please carefully read the following safety warning and download our manual from our website: www.docyke.com



警告说明！WARNING!

请在成人指导下安装使用。

This ride has to be assembled by an adult.



警告说明！

多可 的装配和使用需由成人陪同，并且成人需悉知所有警告条款和安装注意事项。DOCYKE 的所有正规渠道销售的零部件都通过严格测试的合格产品，由于不遵照条款带来的人员受伤或产品损坏，我们将不承担任何责任。



WARNING!

DOCYKE use only under close adult supervision. Parents must review the following warnings and instructions with each ride that is being build. It is your responsibility to review this information and make sure that all riders understand all warnings, cautions, instructions and safety topics, and assure that young riders are able to safely and responsibly use this product. We recommends that you periodically review and reinforce the information in this manual with younger riders, and that you inspect and maintain your docyke rides to insure their safety.

The rides that you can find in our manuals have been tested by official independent testing agencies. We will not be responsible or liable, directly or indirectly, in any way for any loss or damage of any kind incurred as a result of your decision to build constructions or rides that differ from the official rides that we show in our manuals.

多可 使用规范：

DOCYKE use specification:

- 1) 多可 由多个零件组装而成，在使用过程中会造成零件松动，请及时检查并紧固好零件。
Check frequently if all parts are still firmly tightened and function properly.
- 2) 多可 的所有零件都为官方测试的合格零件，但如果不按操作说明，超过零件的装配力矩 (15NM) 或产品的承重载荷会损坏零件。

Never exceed the maximum weight and assembly force(15nm).You can find the maximum weight for every specific ride in our manual.

- 3) 应尽量避免暴露在阳光, 水, 沙堆, 泥土等会造成其老化和缩短使用寿命的环境因素。
Avoid streets and Excessive exposure to sunlight ,water, sand, gravel, and other debris that will shorten the life of the **docyke** .
- 4) 应避免接近尖锐的物体, 以免刮伤其表面, 同时尽量在平缓的地区使用。
Avoid sharp bumps, drainage grates and sudden surface changes. Ride on smooth, paved surfaces.
- 5) **多可** 由很多小零件组成, 部分表面尖锐, 请妥善保管并放置于儿童无法接触到的地方, 以免被幼儿误食或弄伤。
Before assembly, present a choking hazard to children under the age of three. Care should be taken during unpacking and assembly to insure that all small parts and plastic bags are accounted for and kept out of the reach of children.
- 6) **多可** 不用时请放置在干燥的地方妥善保管。
Dirt, leaves, and other debris can damage, shrink, expand or weaken **docyke** parts. Keep your ride in a dry environment.
- 7) **多可** 除螺钉外其余都为特别设计的零件, 请不要和市场上类似零件混用。
Most of the **docyke**' s components are specially designed, please do not mix with similar parts on the market.
- 8) 检查充气轮胎气压不能大于1.8bar (1.8 kgf/cm²)
Check the air pressure in the tires to max 1.8bar
- 9) 适当着装, 不要穿宽松衣物或饰品, 让衣服, 头发远离运动部件, 避免卷入其中。
Dress properly. Do not wear loose clothing or jewelry. Keep your hair, clothing and gloves away from moving parts. Avoid caught in moving parts.
- 10) 佩戴好个人防护装置, 安全装置后使用 **多可**, 如防滑鞋, 安全帽, 等。
Use personal protective equipment. Always wear protective equipment such as non-skid safety shoes, hard hat etc.
- 11) 在进行任何调节, 更换附件或储存 **多可** 之前必须使电池与产品脱开, 减少以外启动危险。
Disconnect the battery pack from the **DOCYKE** before making any adjustments, changing accessories, or storing **DOCYKE**.

电气安全警告:

阅读所有警告及说明! 不遵照以下警告和说明会导致电击, 着火或严重伤害!

Electrical safety warning:

Read all safety warnings and all instructions. Failure to follow the warnings and instructions may result in electric shock, fire or serious injury.

- 1) 充电器仅中室内使用, 并使充电及使用环境的清洁, 干燥。不得暴露在潮湿, 粉尘环境中, 否则会增加电击危险。
The recharge is only used indoors, Keep work area clean and well lit. Do not expose **DOCYKE** to rain or wet conditions.



- 2) 只能用 多可 制造商规定的充电器及电池进行充电。
Recharge only with the charger and battery pack which specifically designated by DOCYKE.
- 3) 当电池不用时, 将它远离其它金属物体, 以防电池短路引起火灾或燃烧。
When battery pack is not use, keep it away from other metal objects that can shorting the battery terminal together may cause burns or fire.
- 4) 严禁打开电池及充电器, 可能造成短路, 火灾或燃烧。保护电池免受高温 (如长时间日照), 火焰, 水和湿气的侵害。有爆炸危险。
Do not open the battery and charger. Danger of short-circuiting. Protect the battery against heat, e.g, against continuous intense sunlight, fire, water, and moisture. Danger of explosion

有任何疑问, 随时向您的经销商,
或致电向我们进行询问。
Web: www.docyke.com

建议使用工具/RECOMMENDED TOOLS



六角扳手/Hex Key



六角柄/Hex handle

DOCYKE 多可

1

装配时螺钉需要拧紧。

Tighten the bolts with full force to prevent them coming loose.

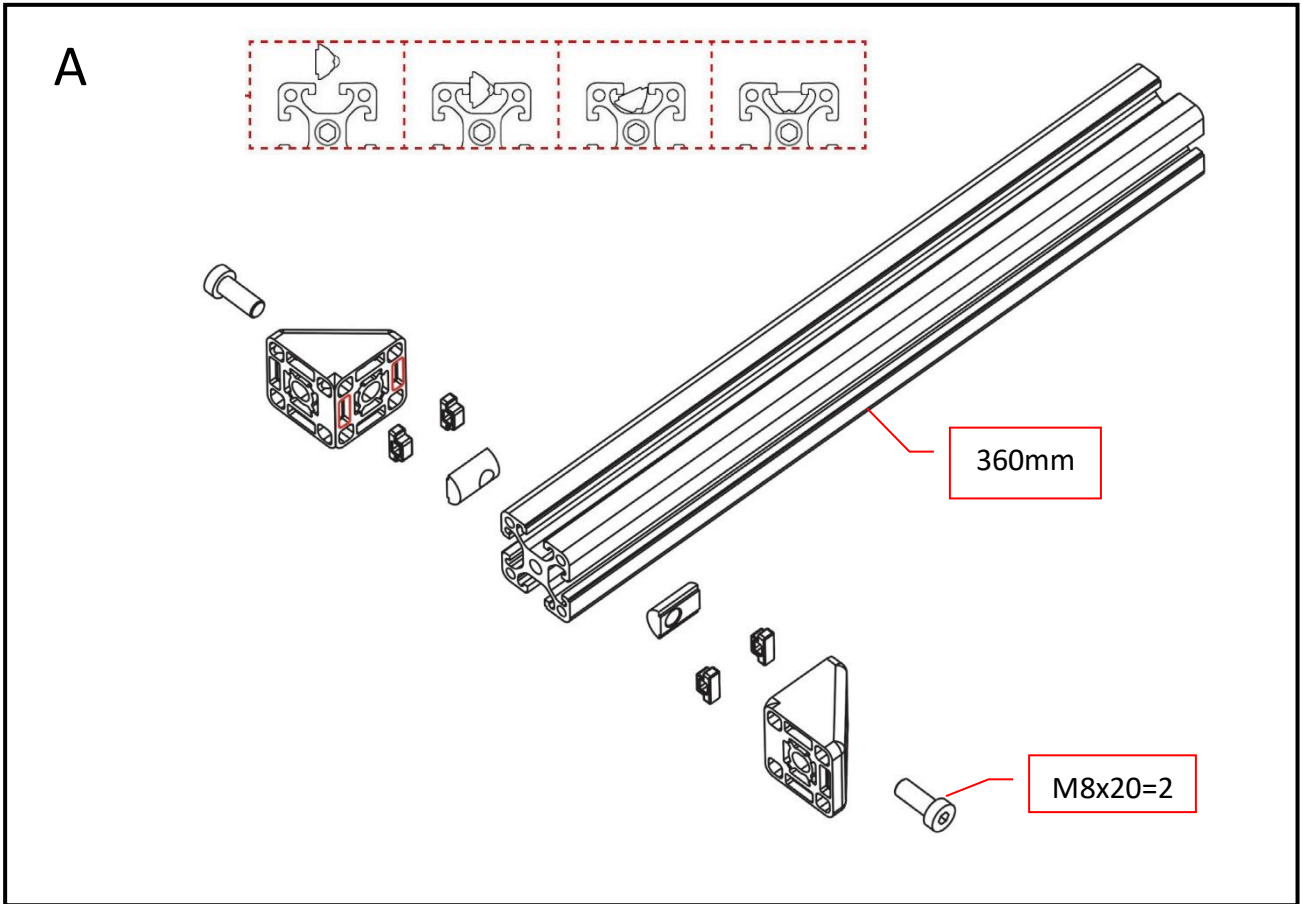

The positioning blocks are some of the smallest parts but they also some of the most important. Putting them in the right place is

产品中一共包含两种定位块，它是至关重要的部件，请仔细分辨，避免漏装或误装。

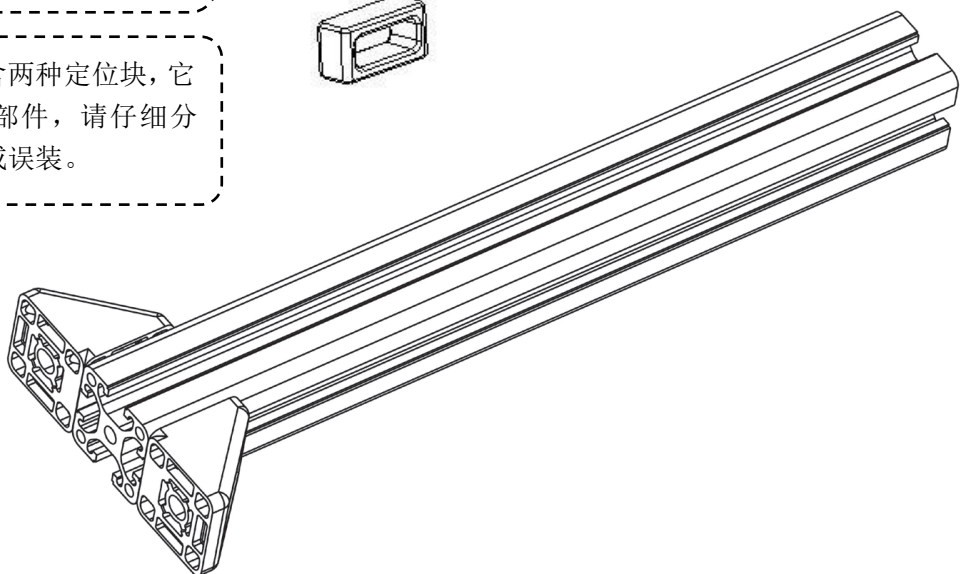
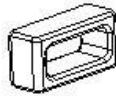
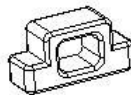

2

A

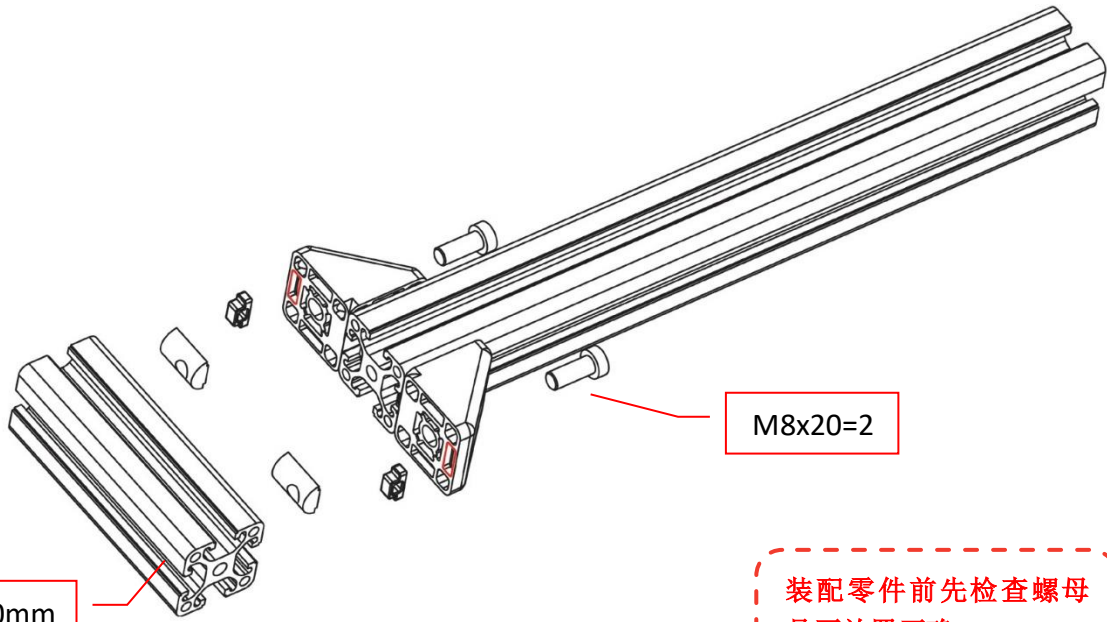

装配零件前先检查螺母
是否放置正确。
Check the profile nut
remains perfectly straight

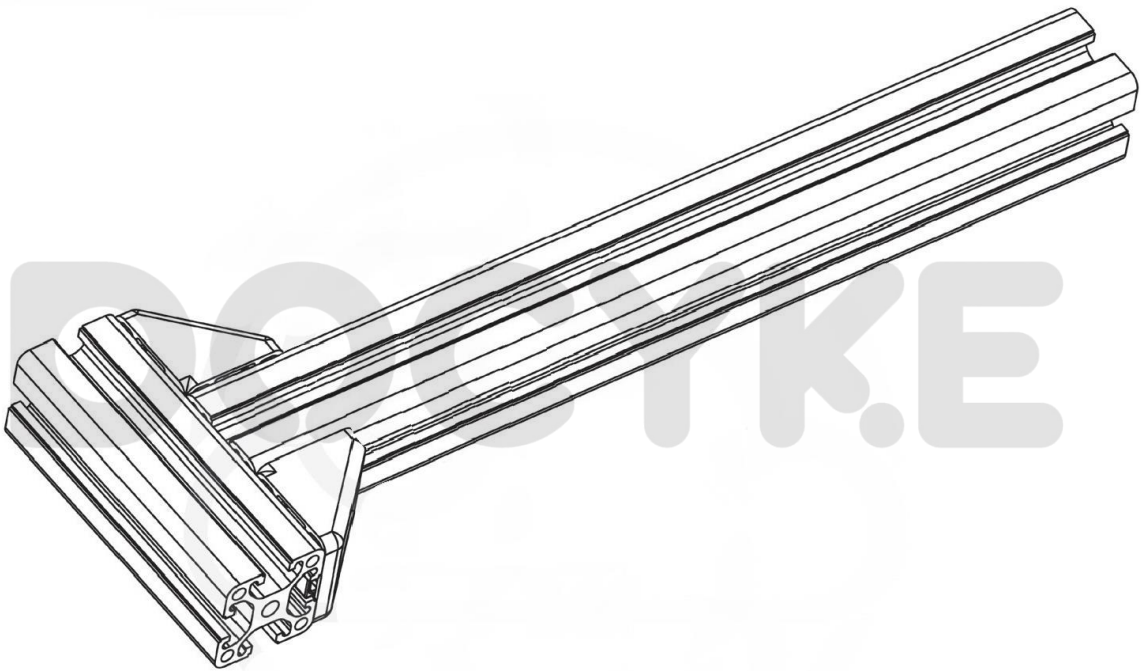

3

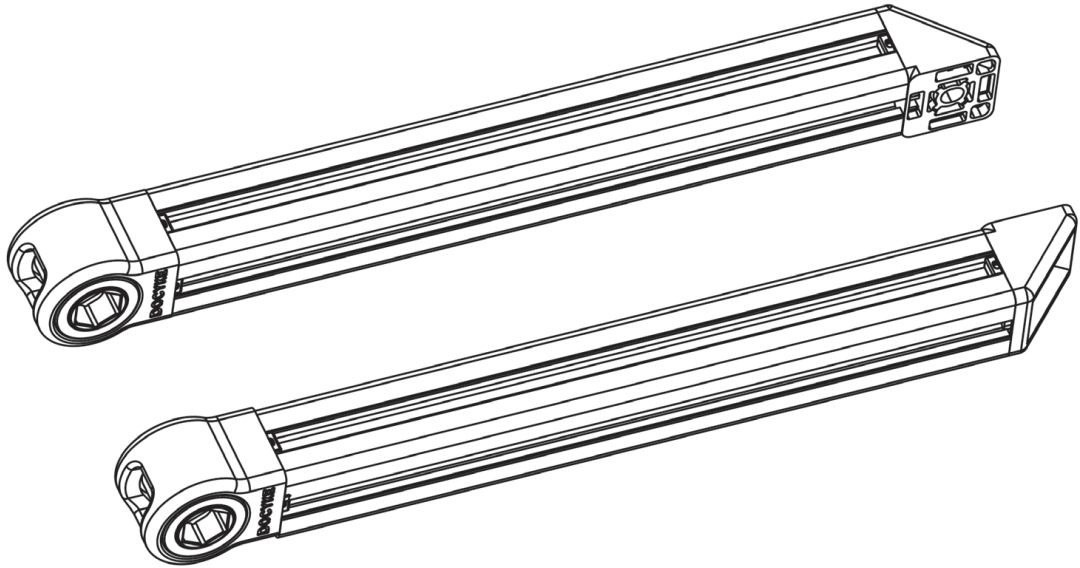
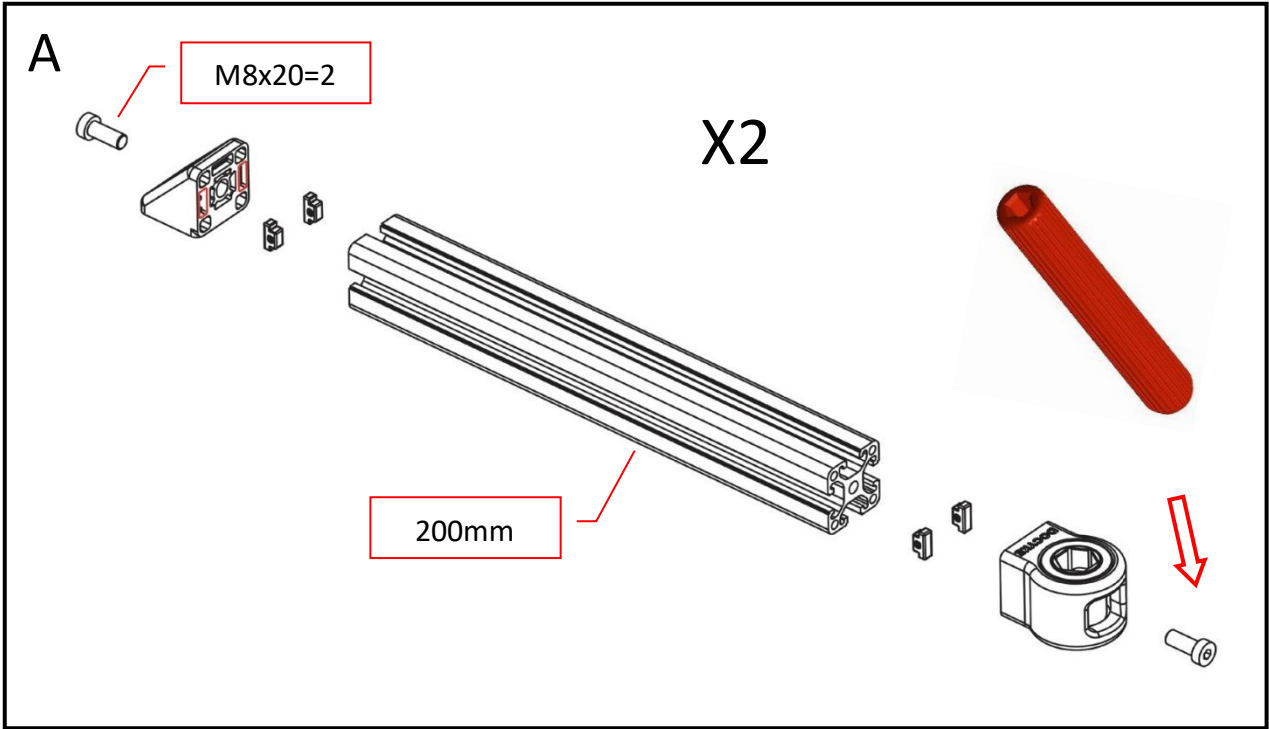

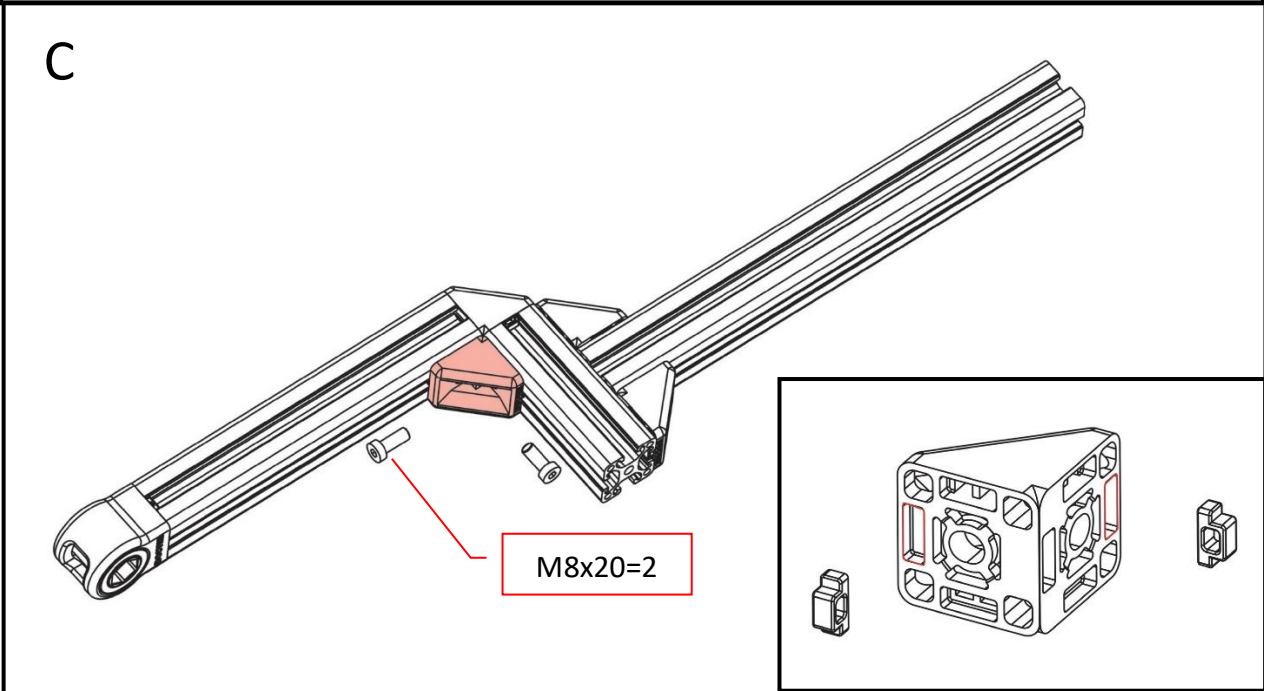
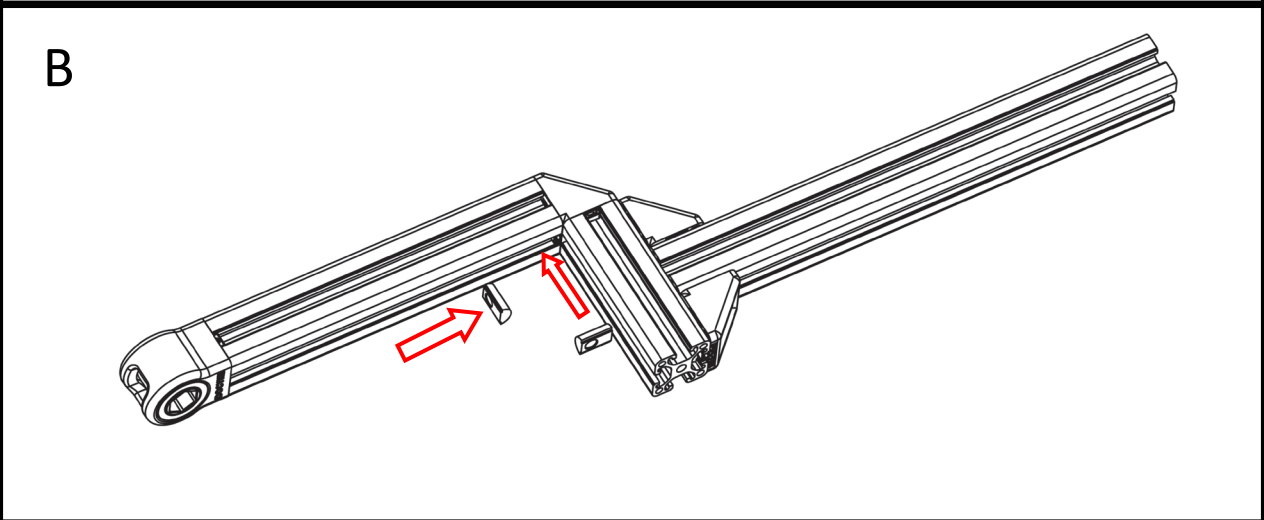
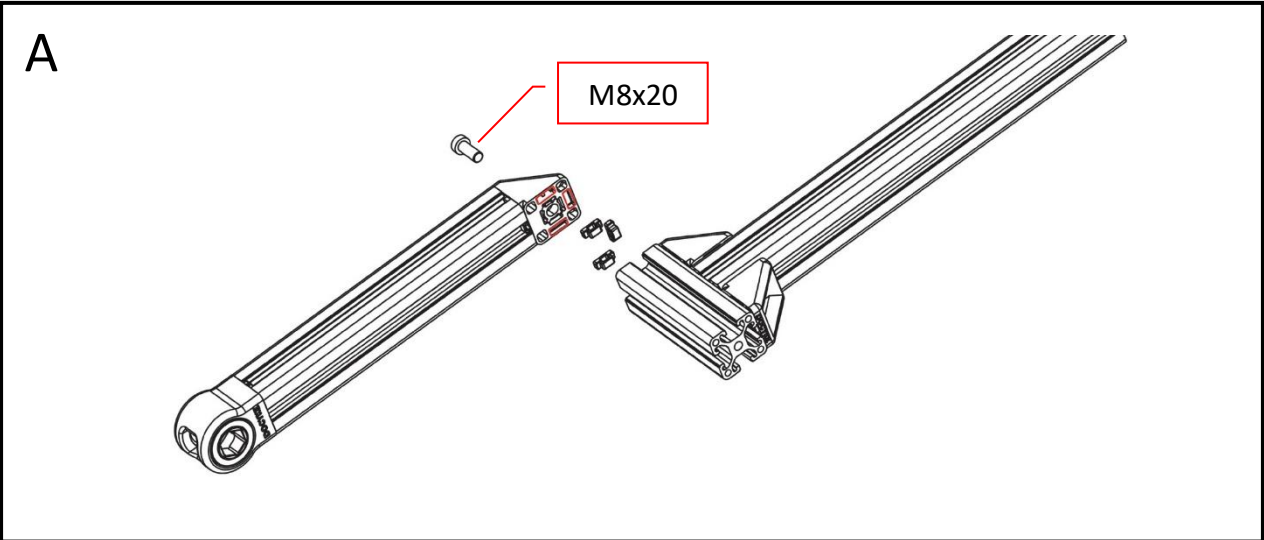

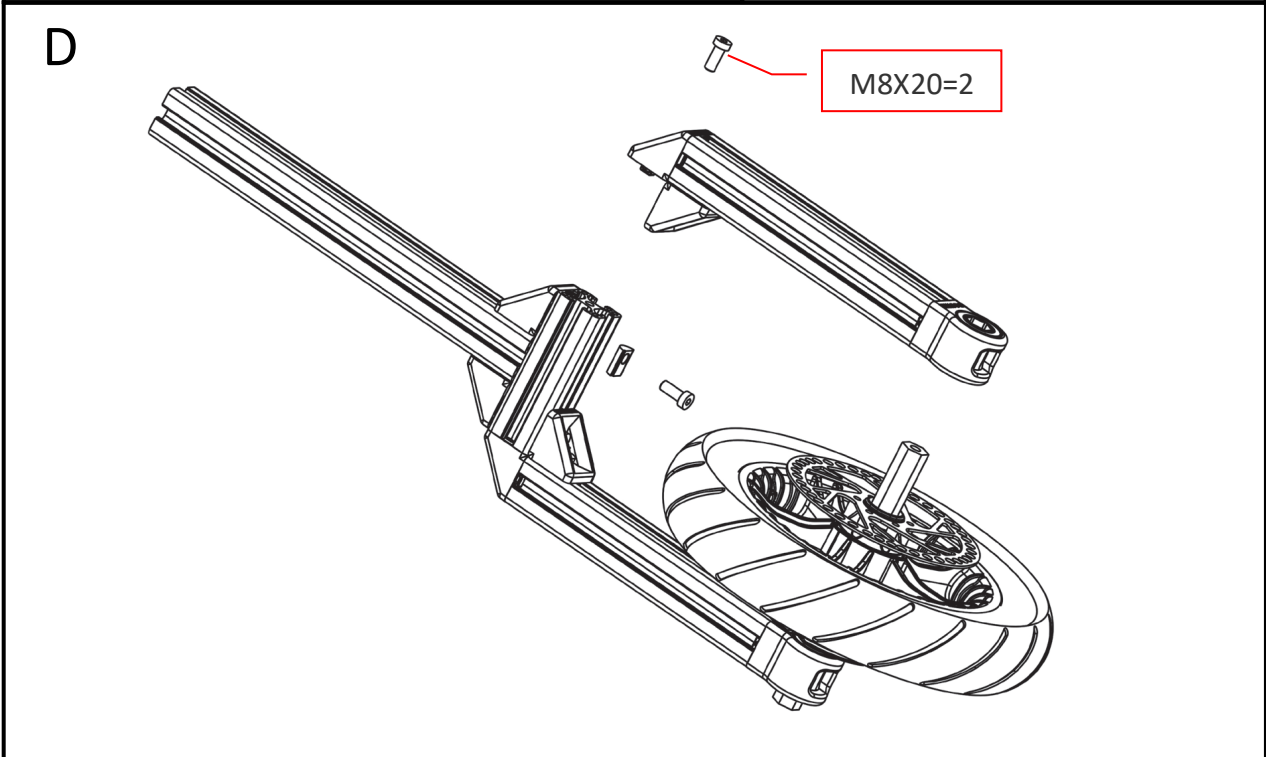
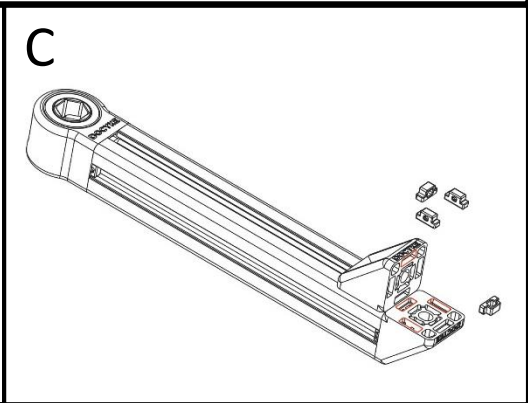
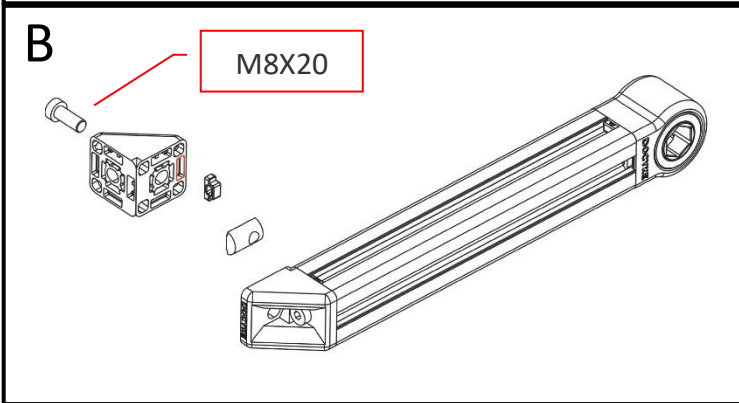
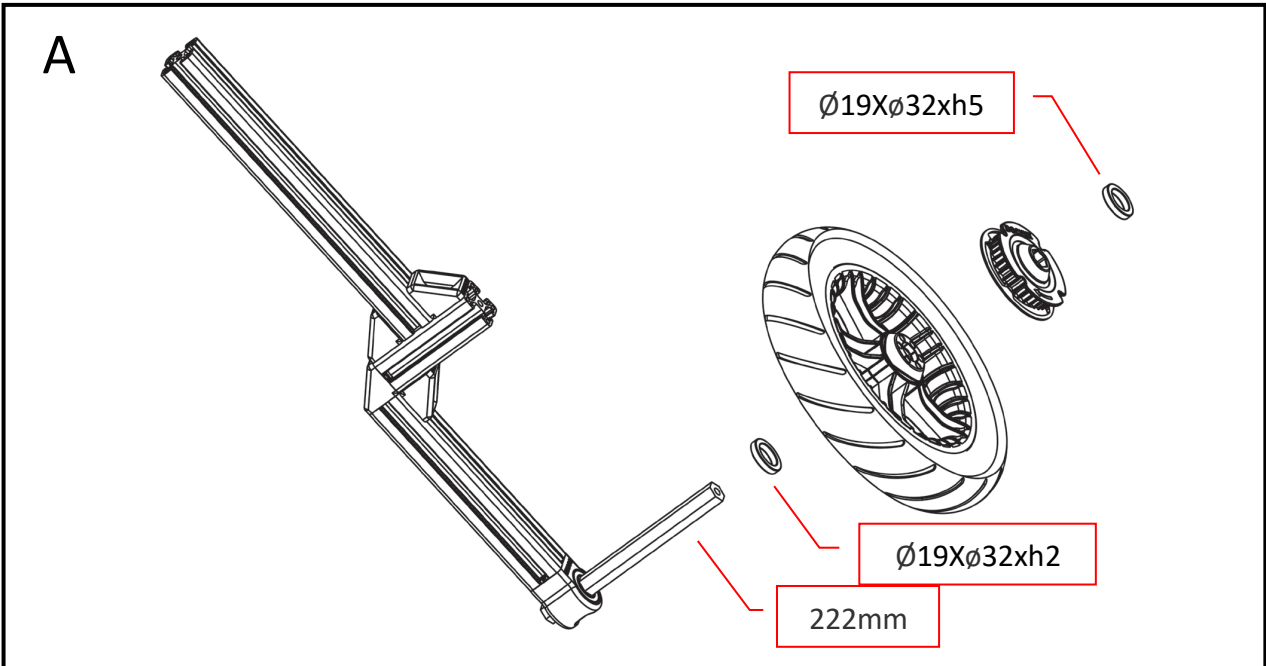

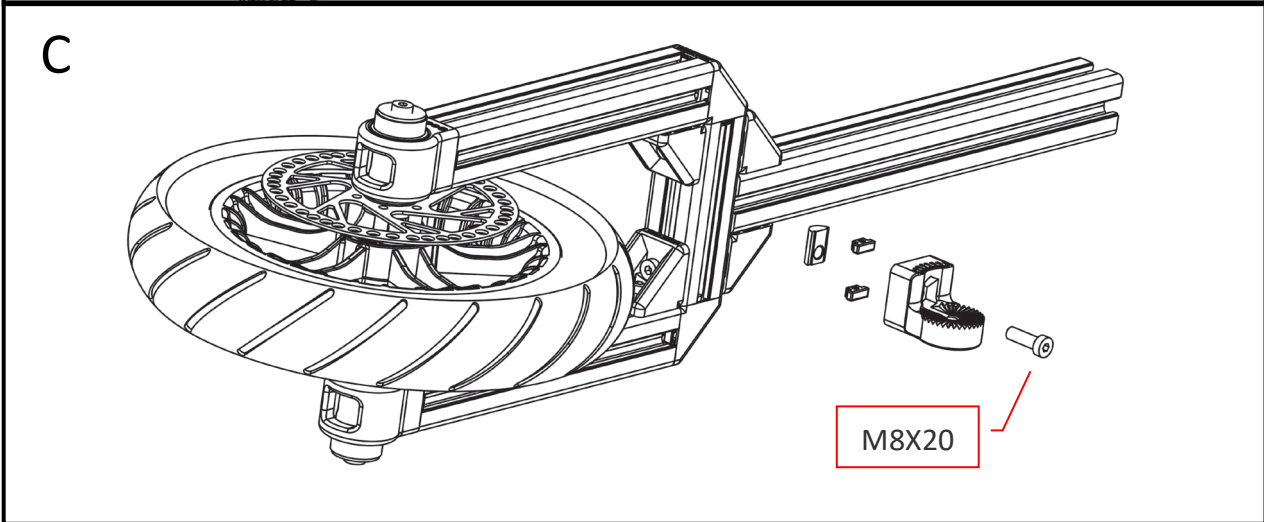
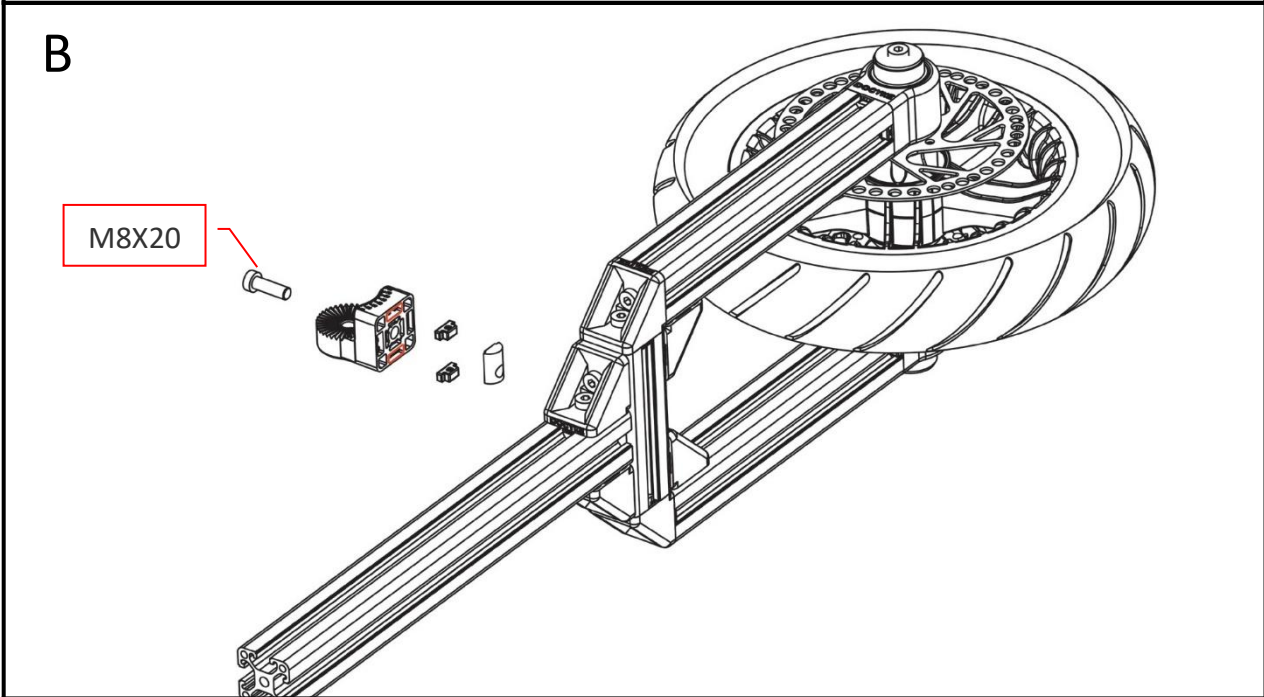
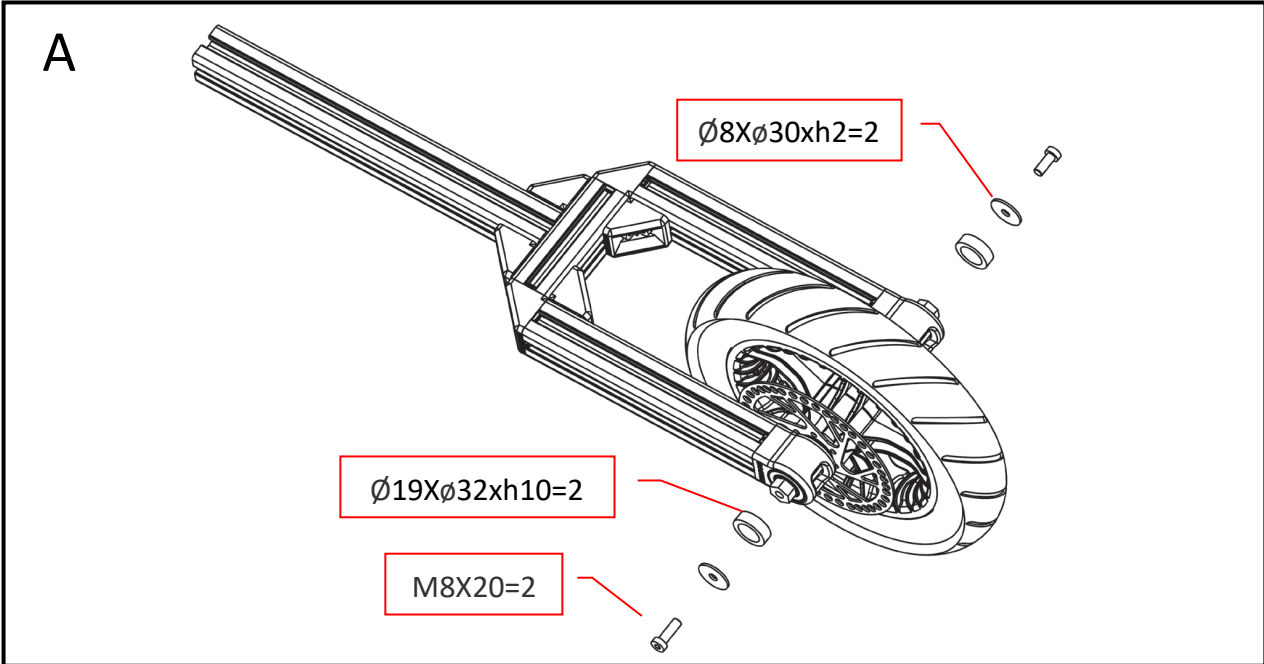

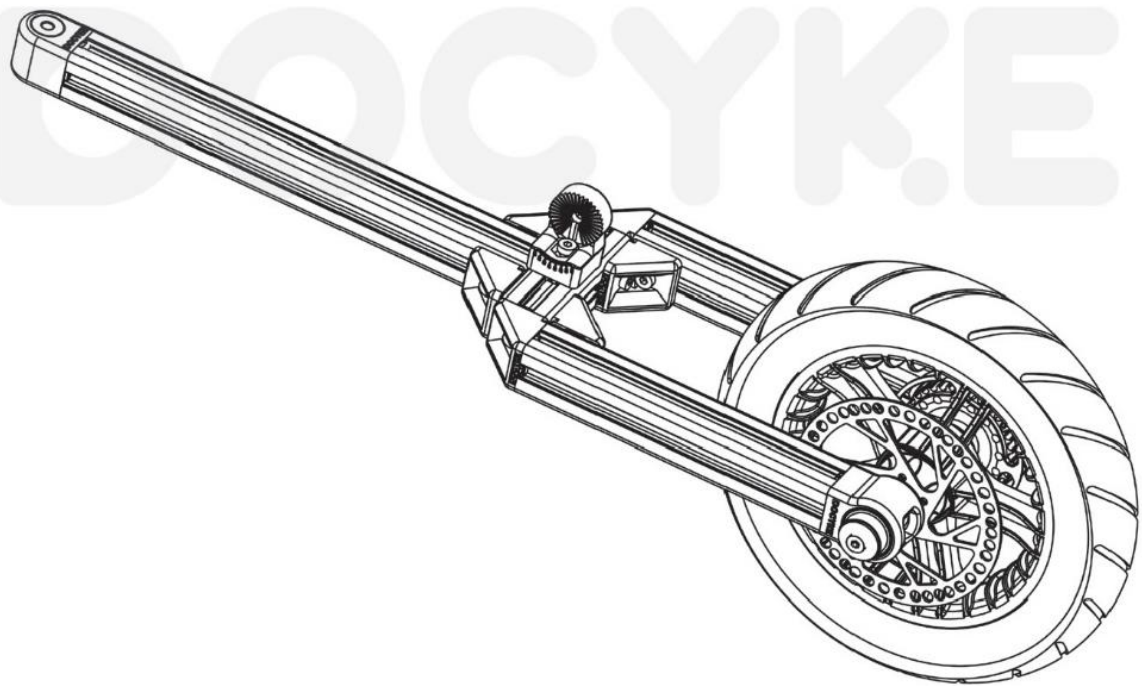
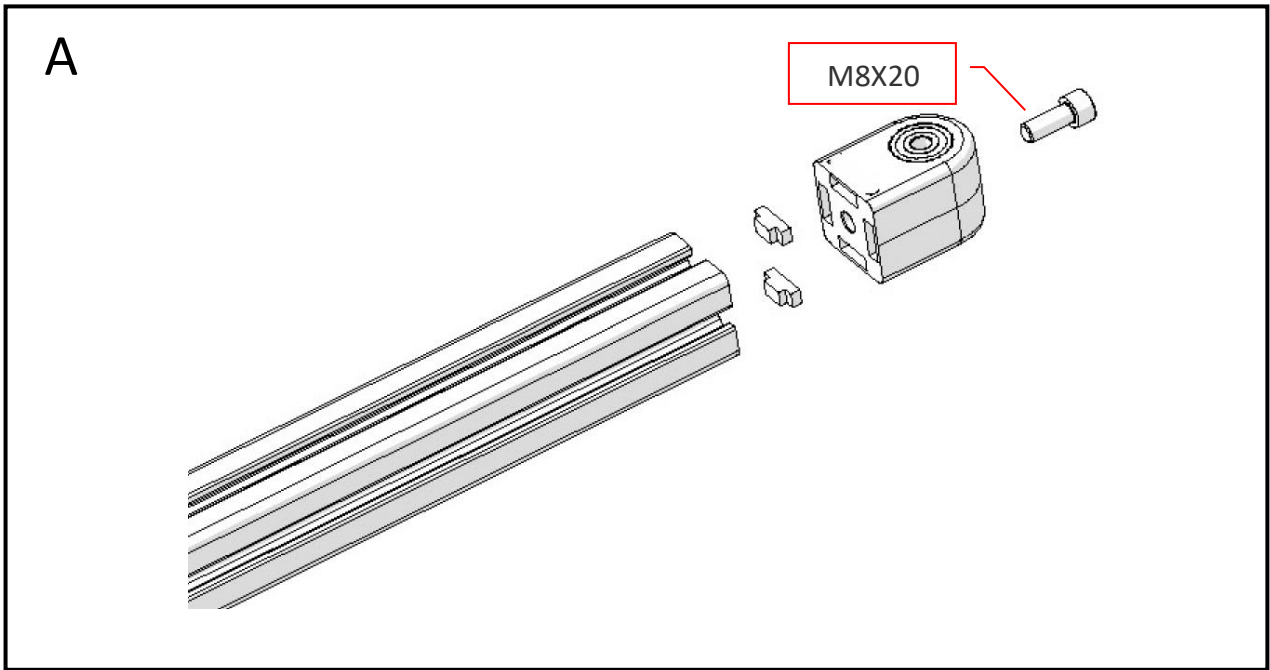

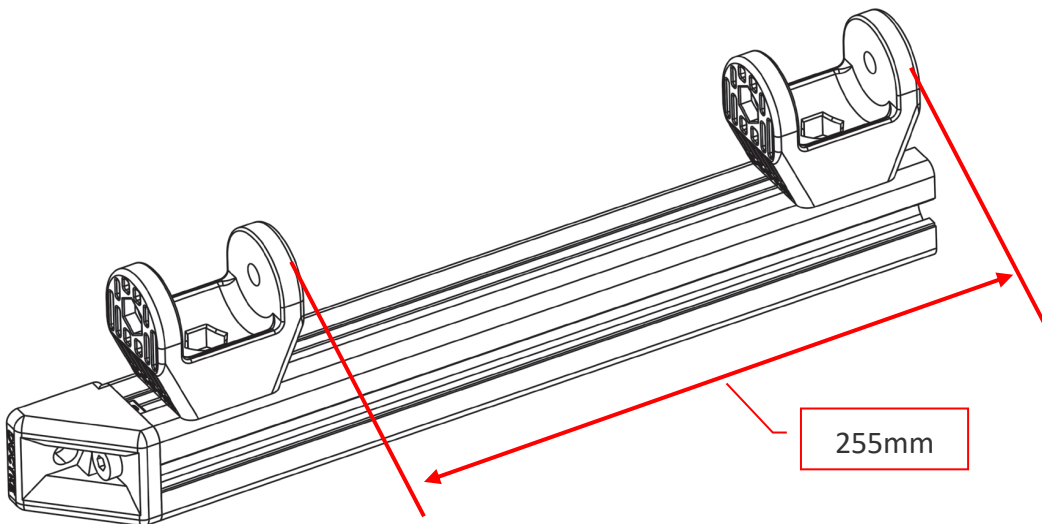
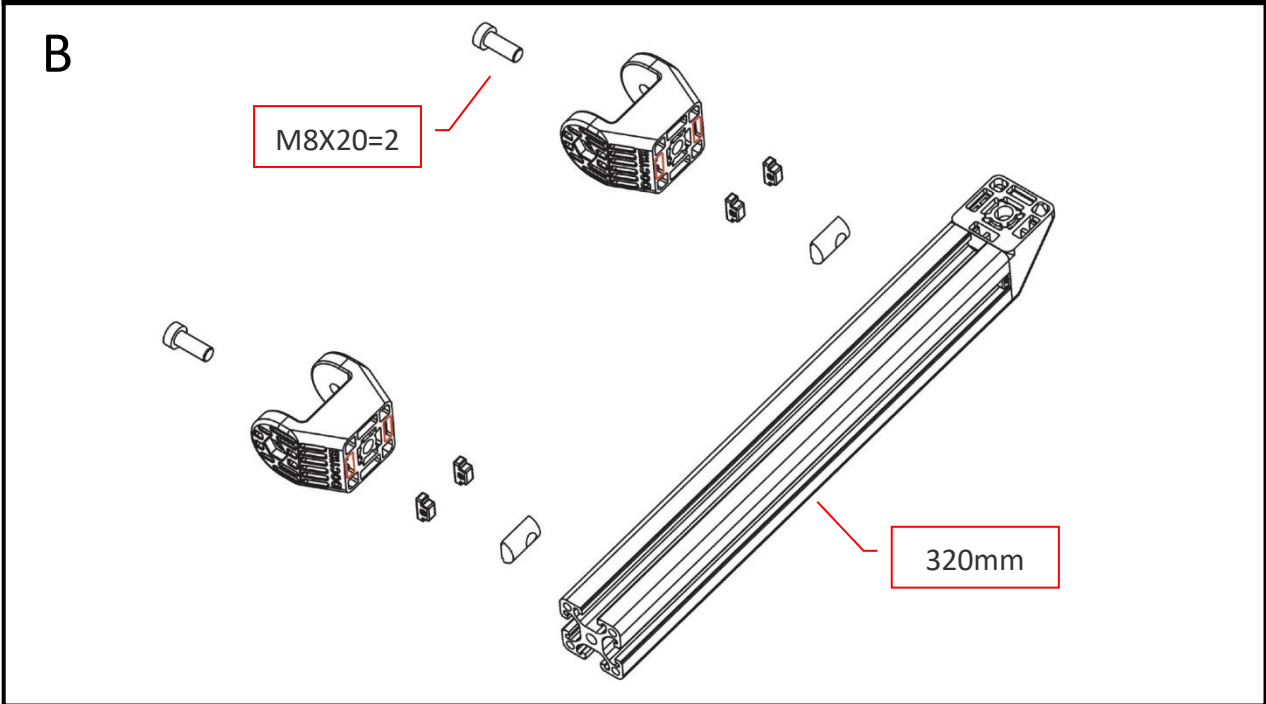
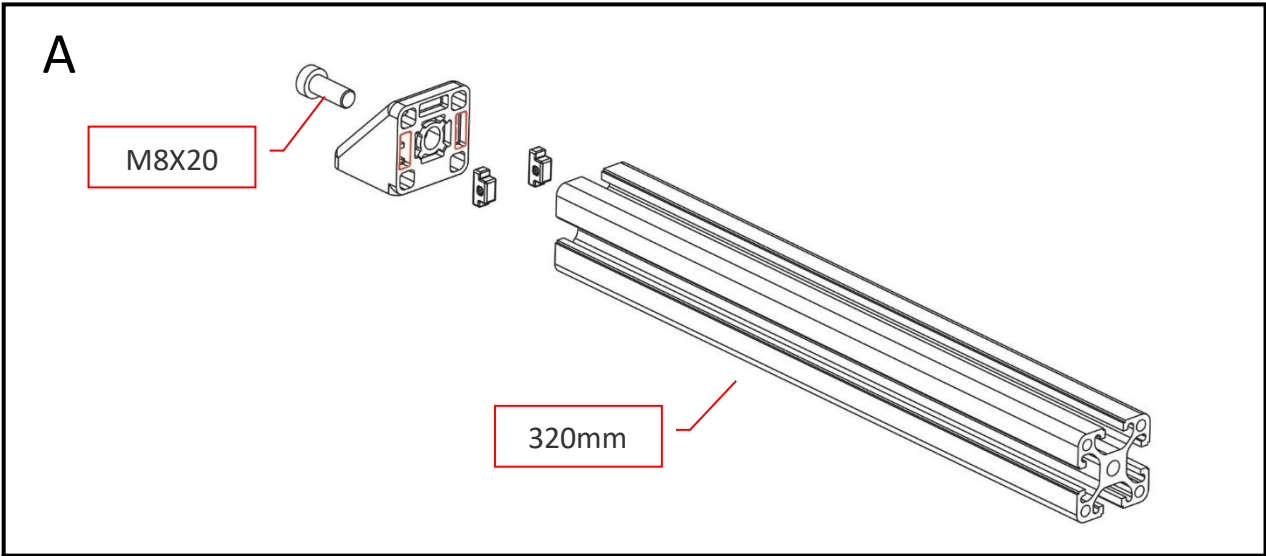

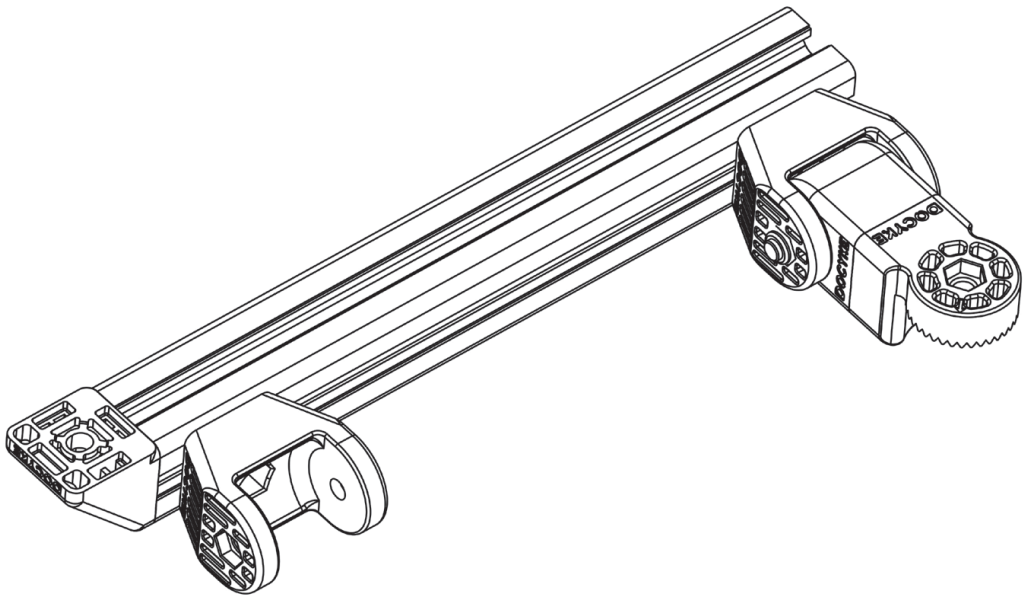
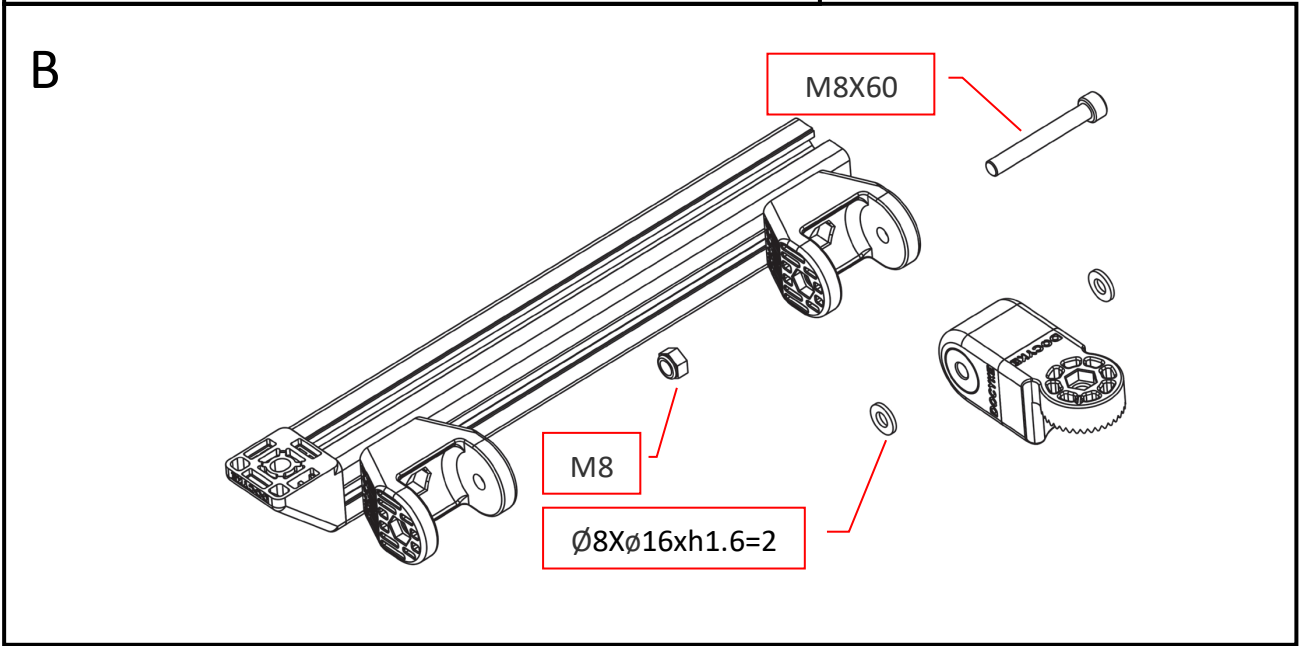
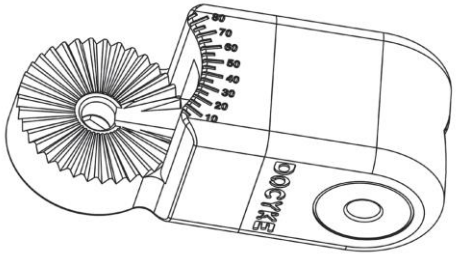
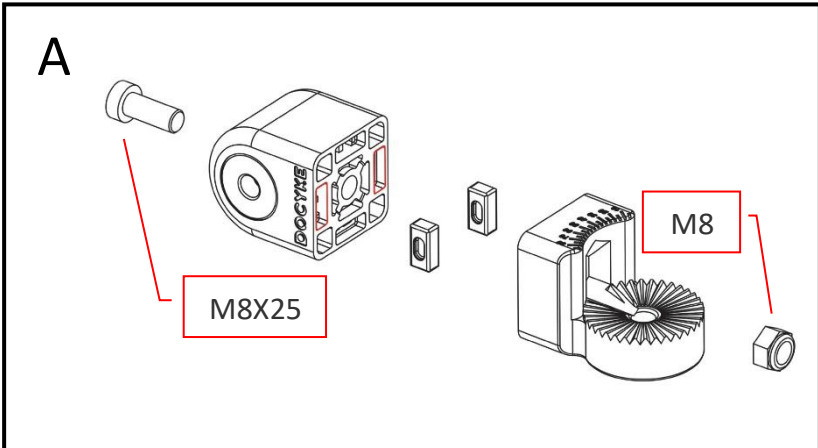

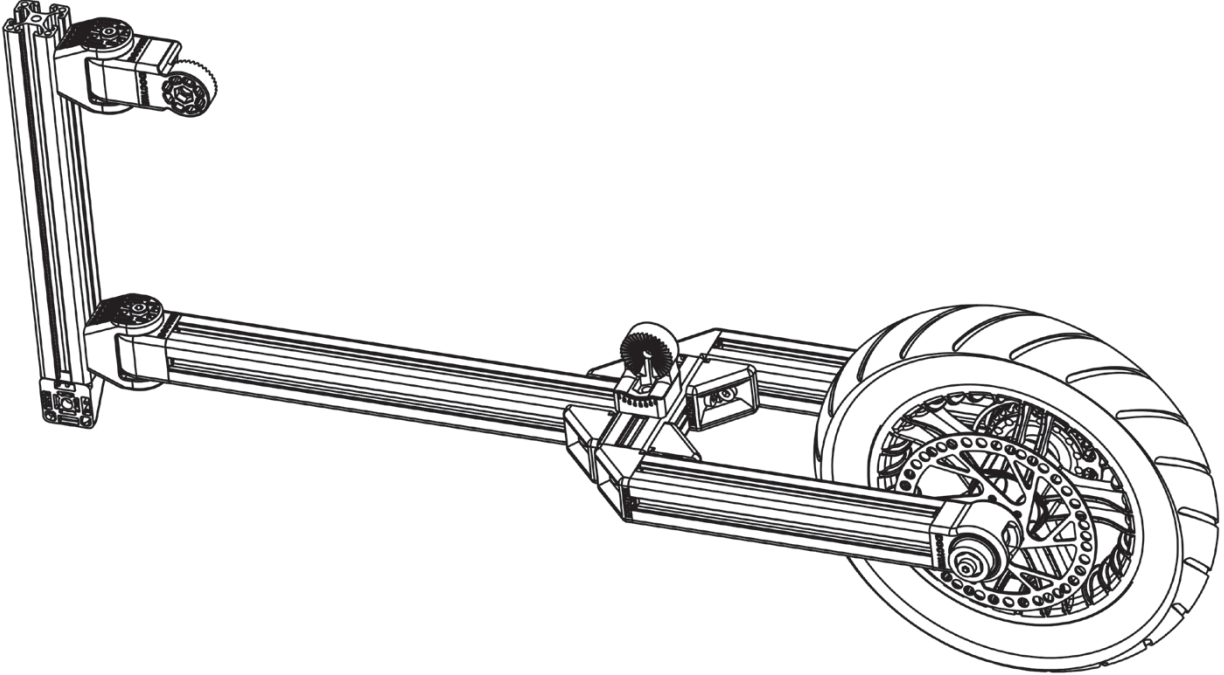
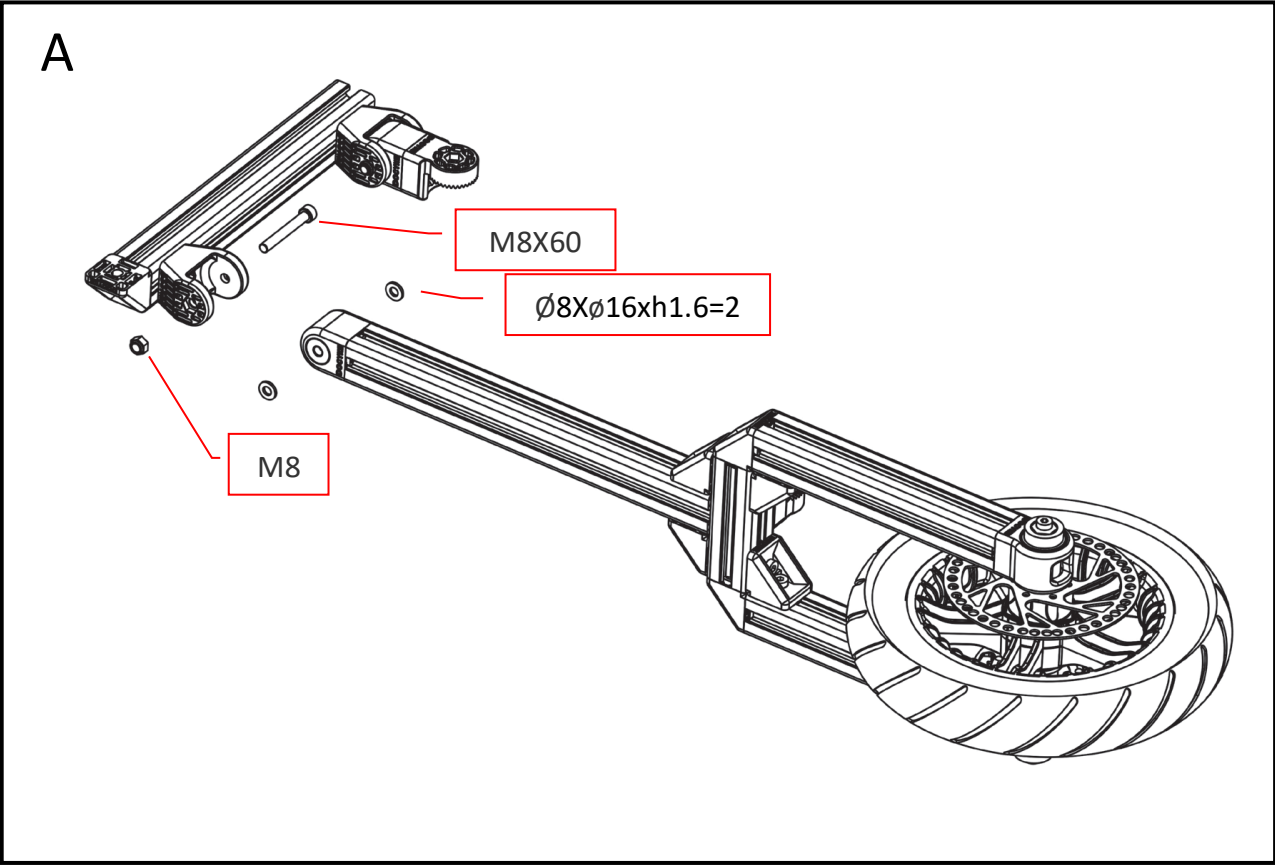

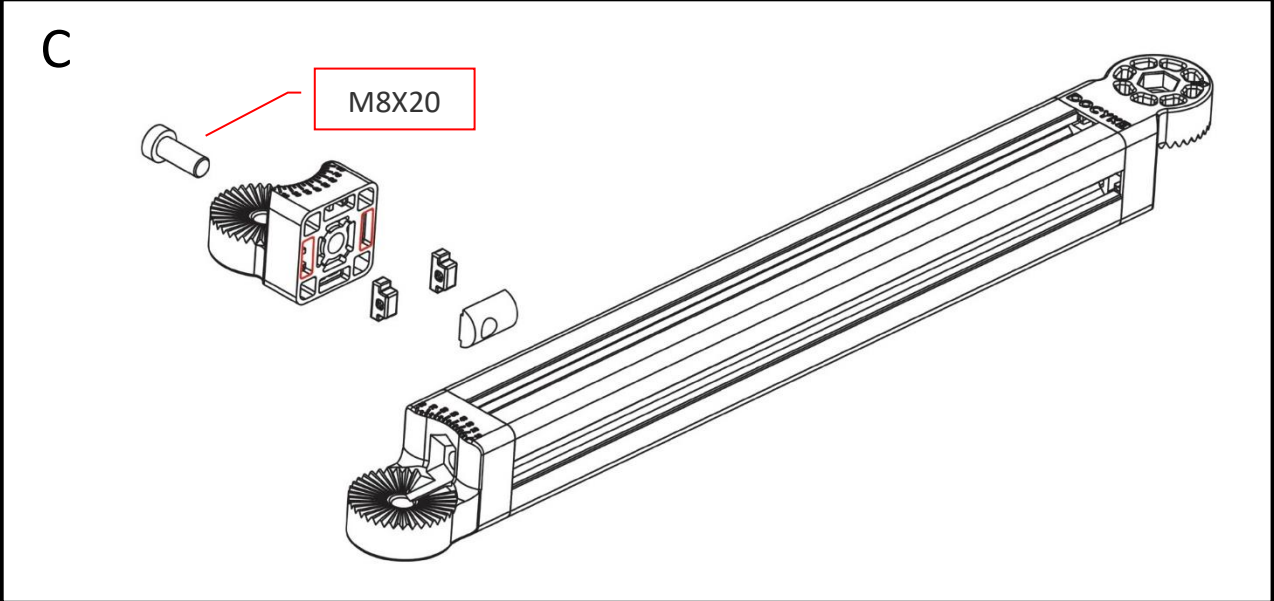
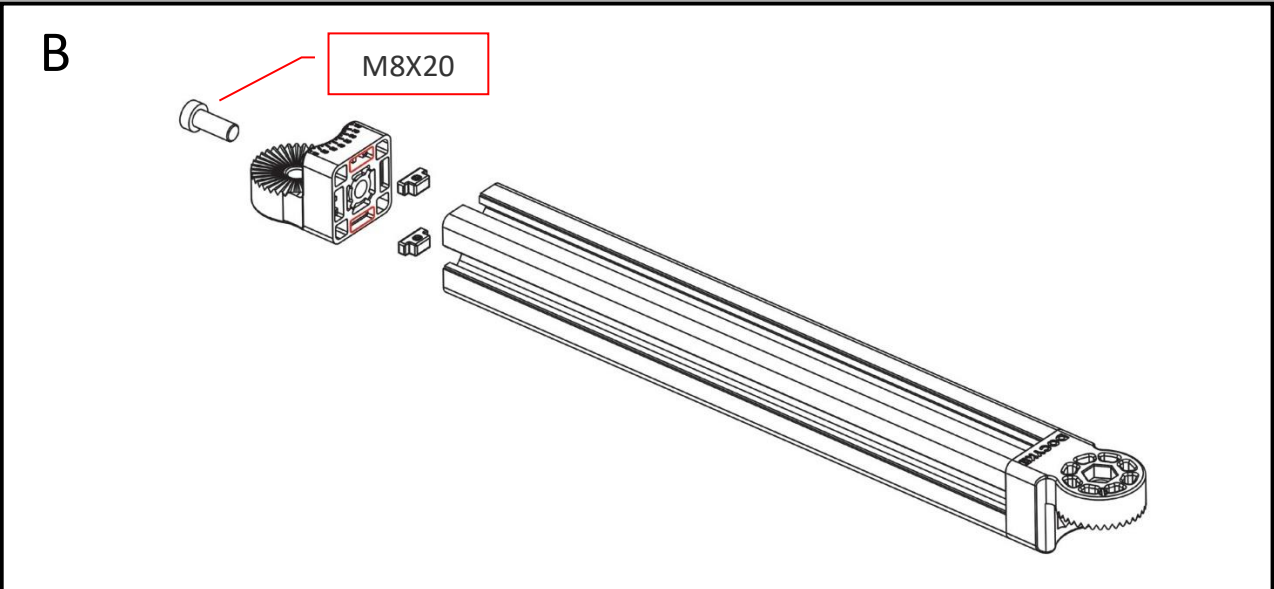
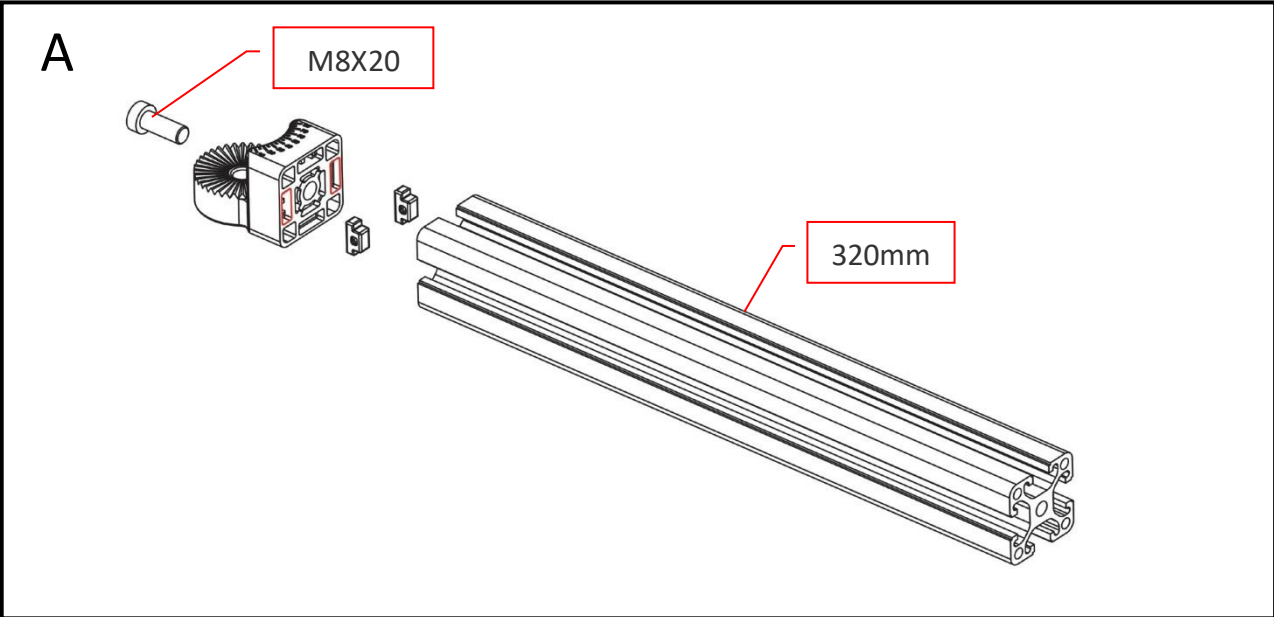

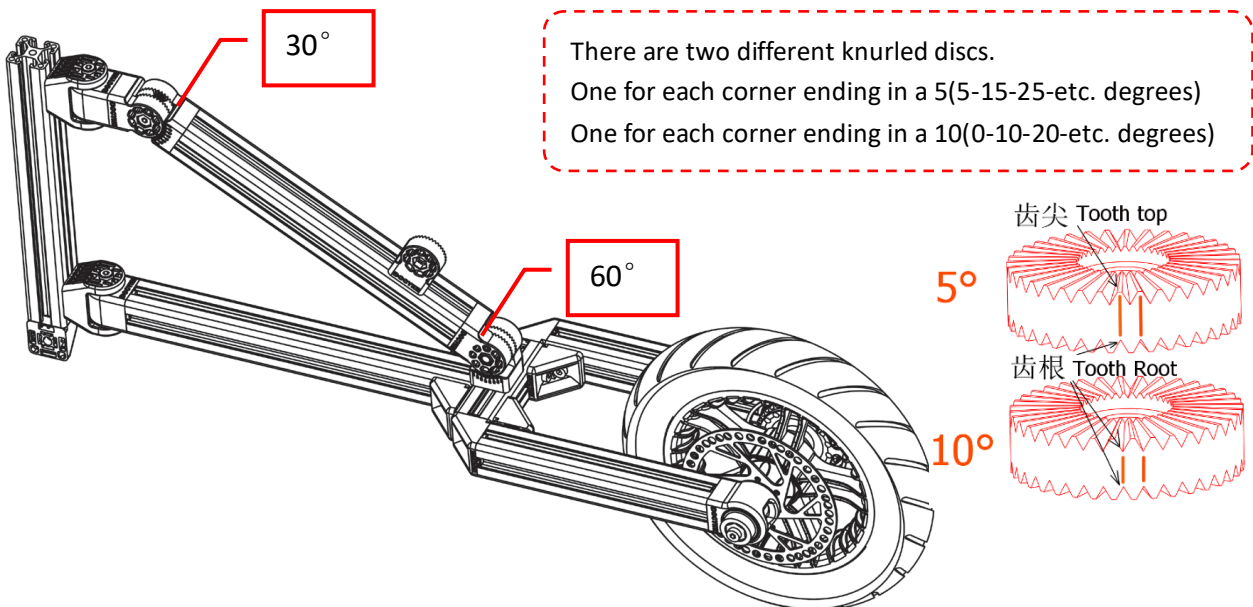
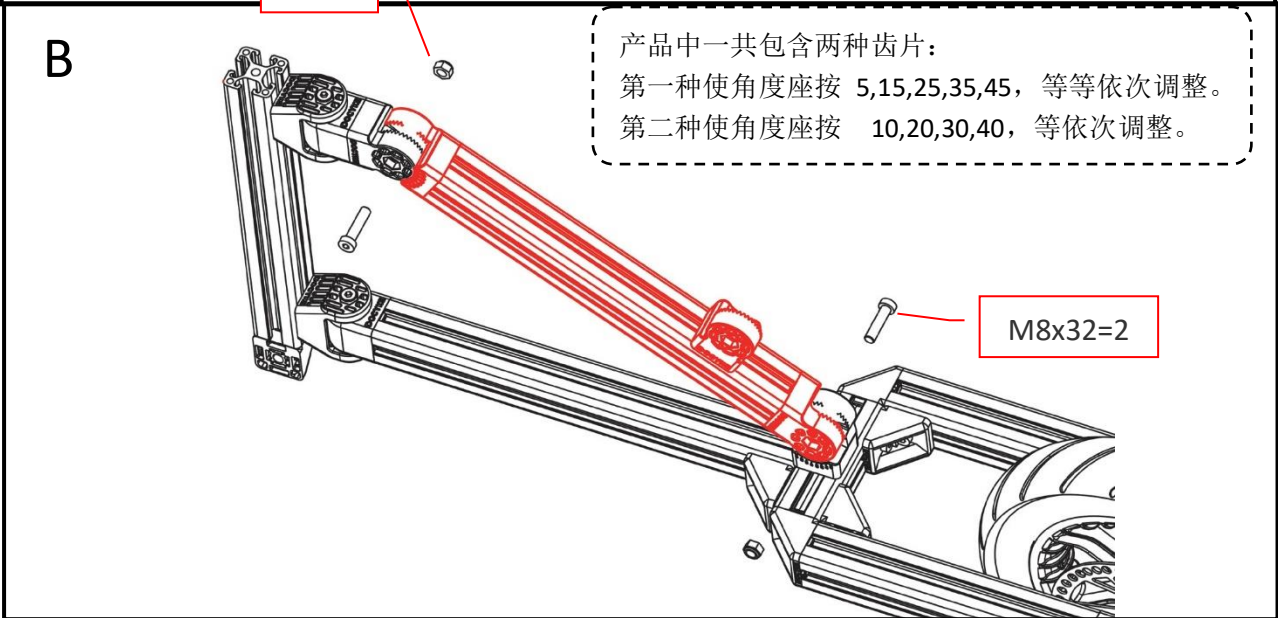
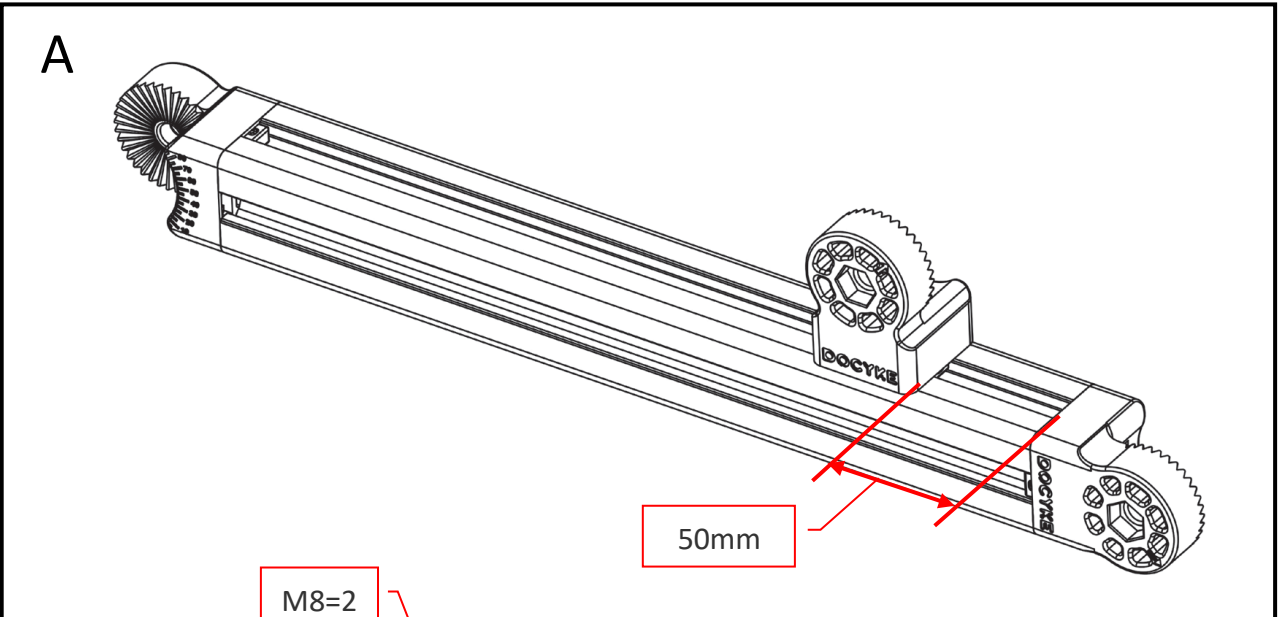

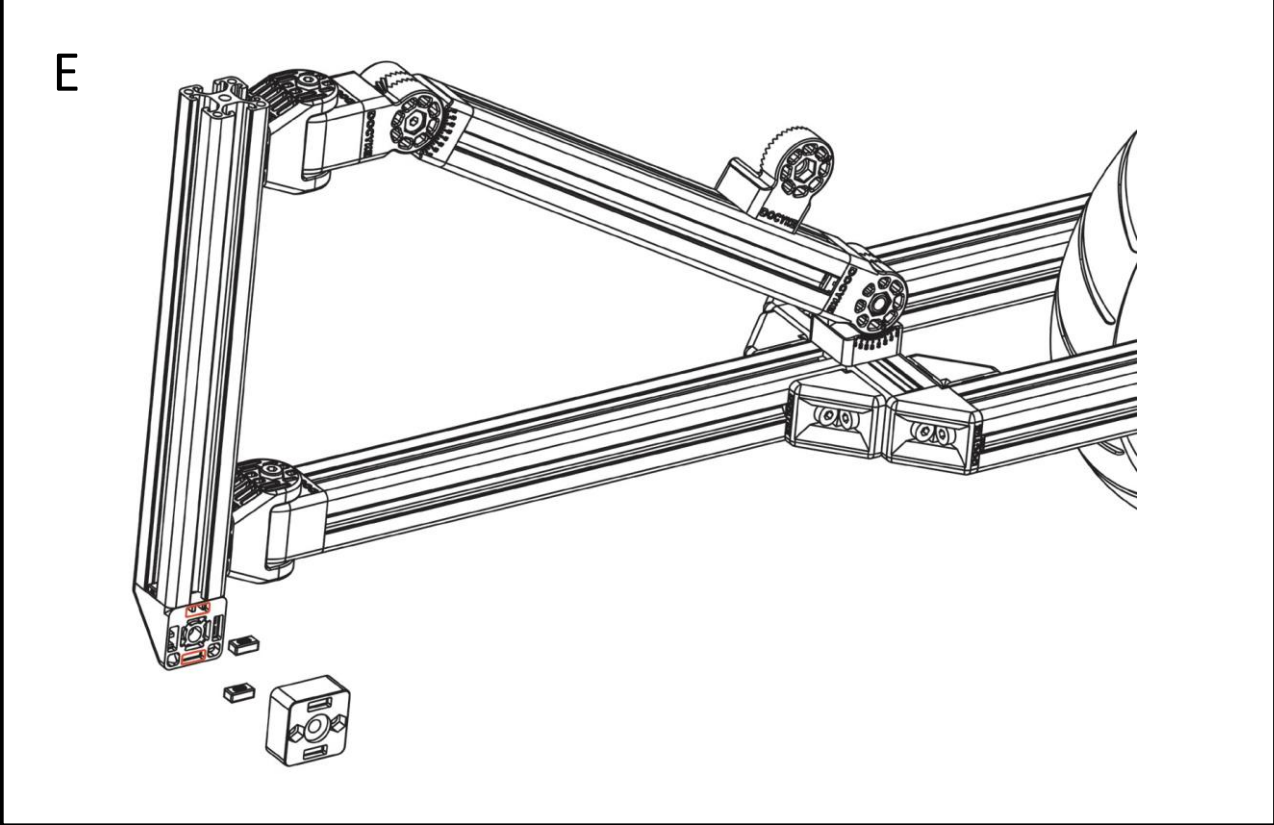
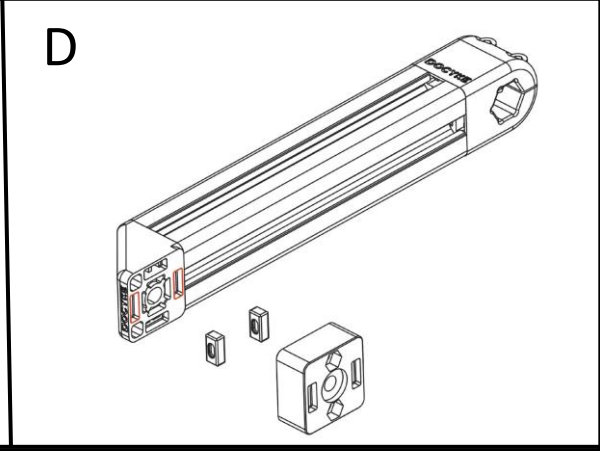
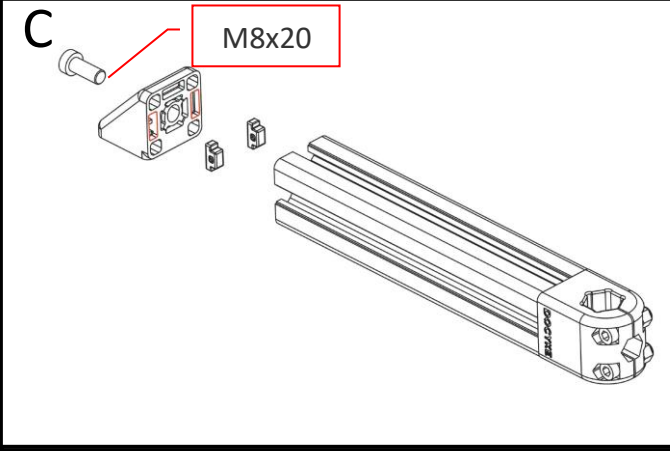
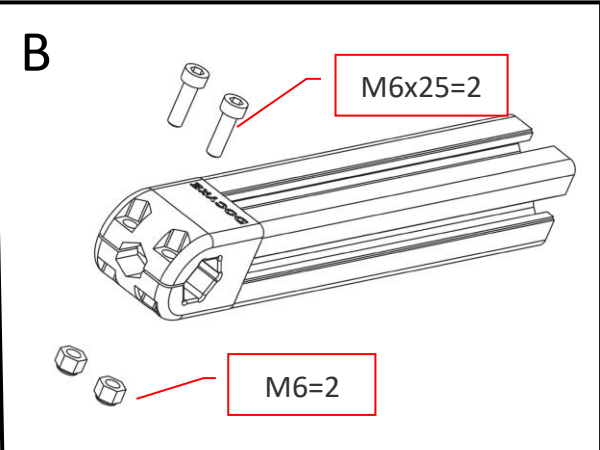
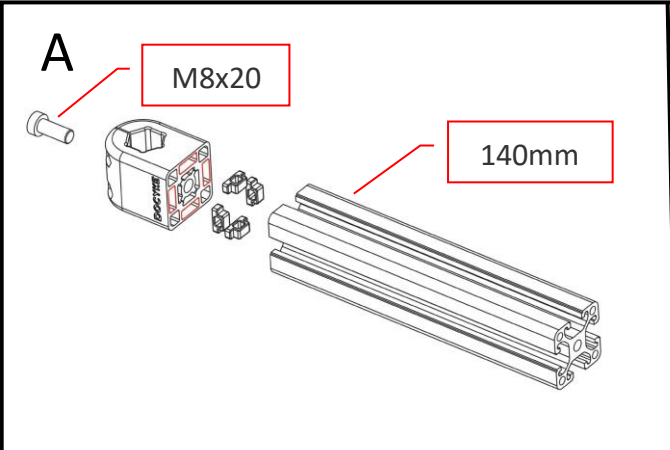

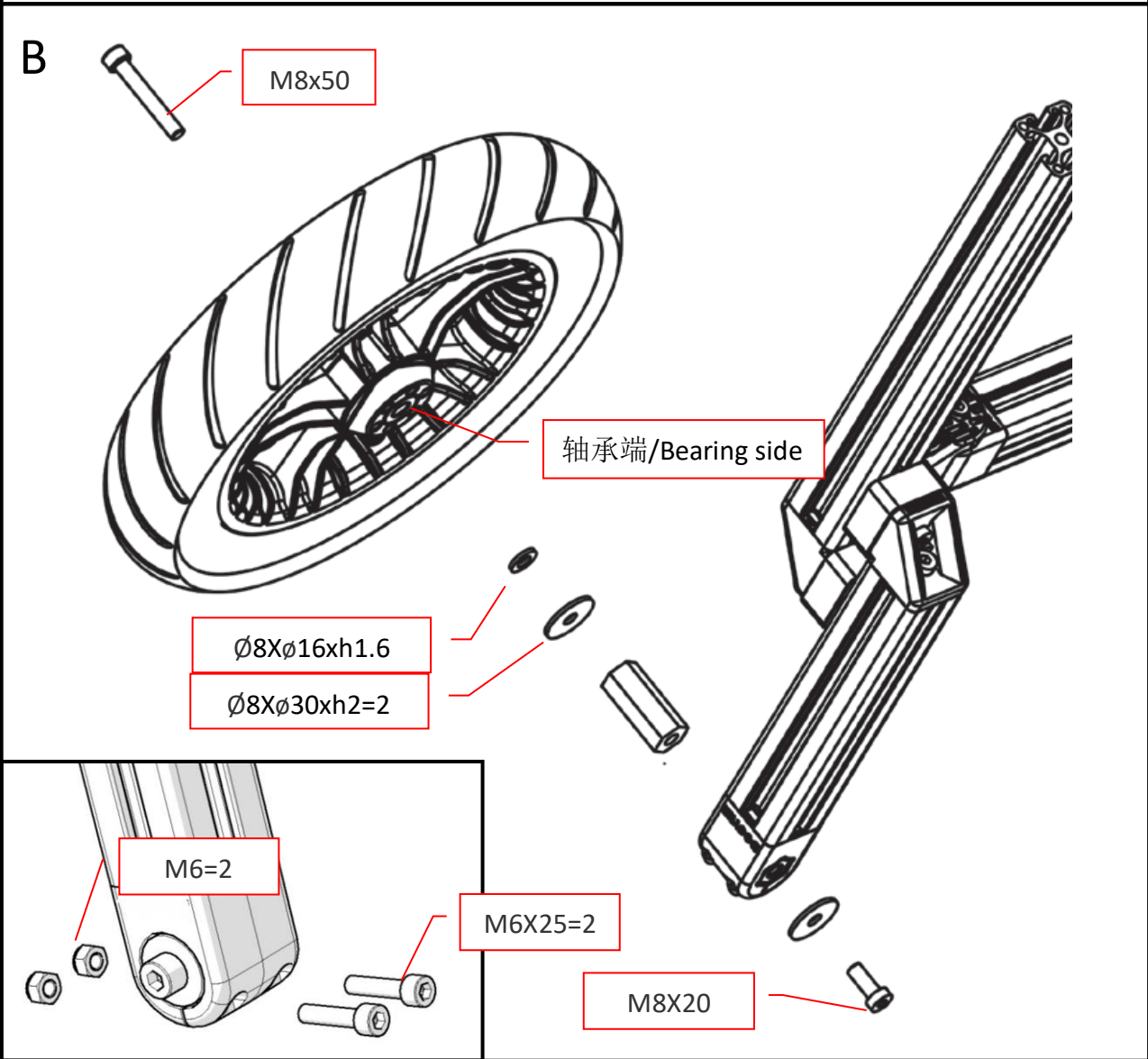
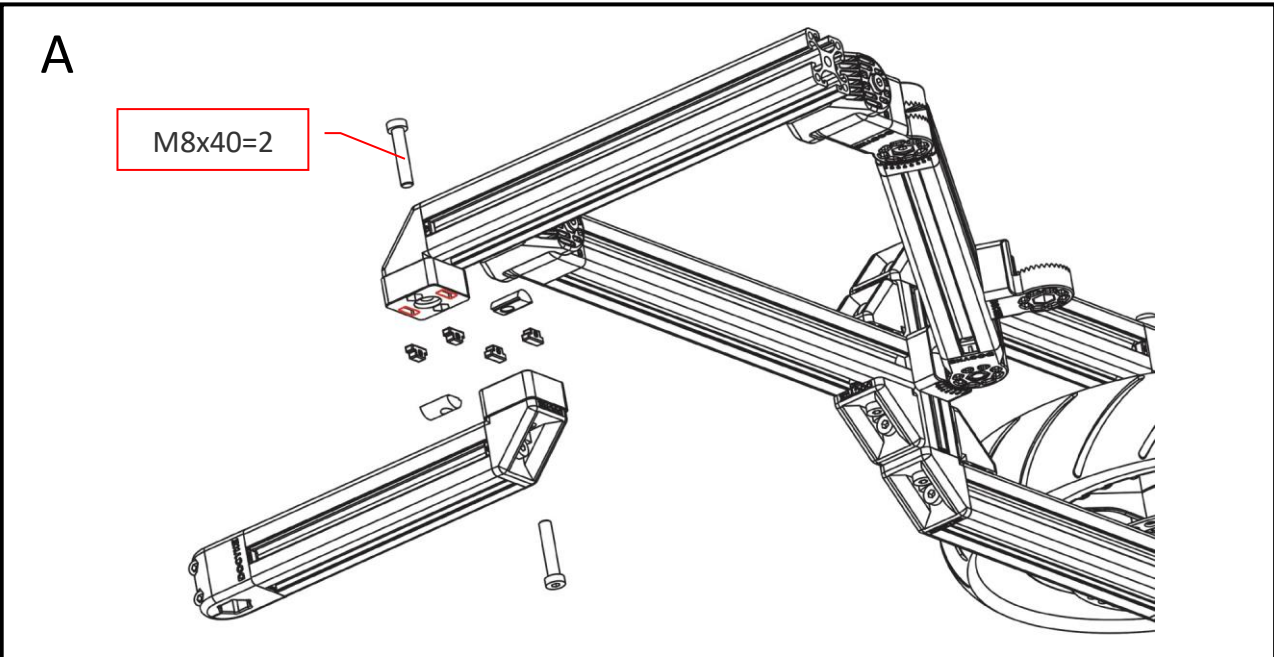

C

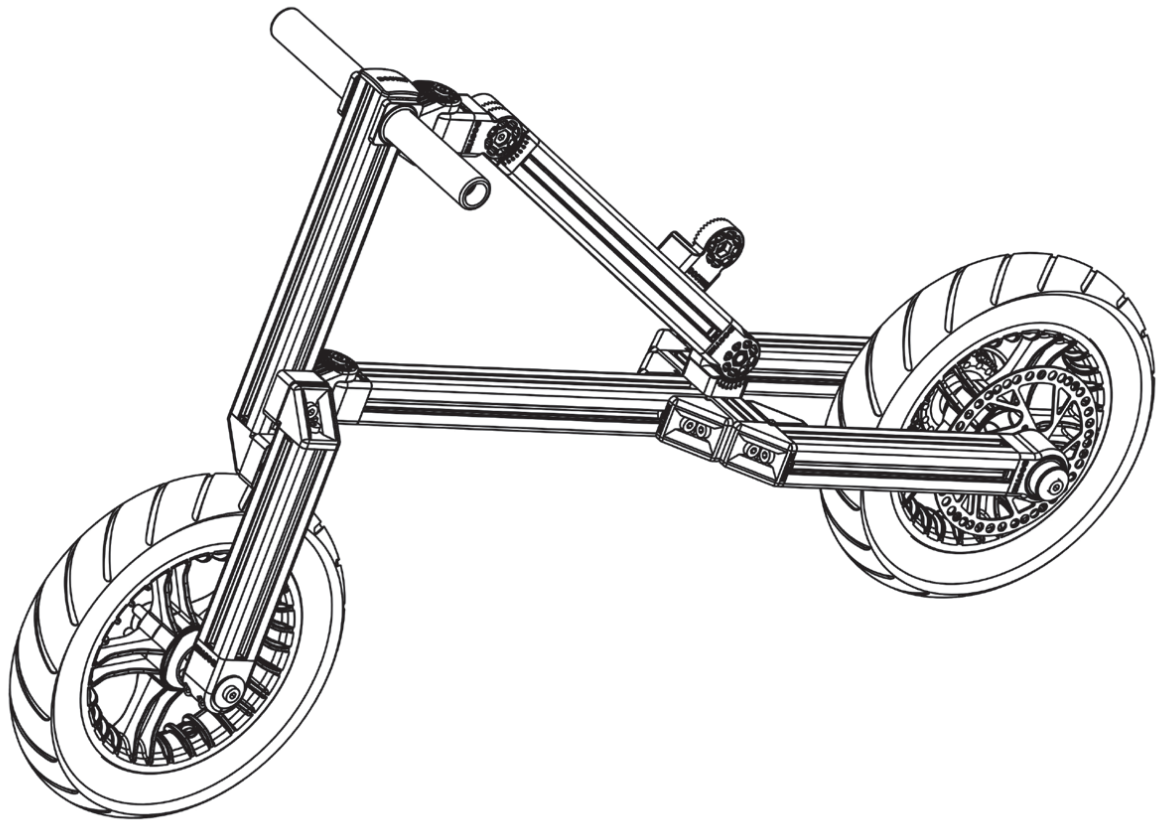
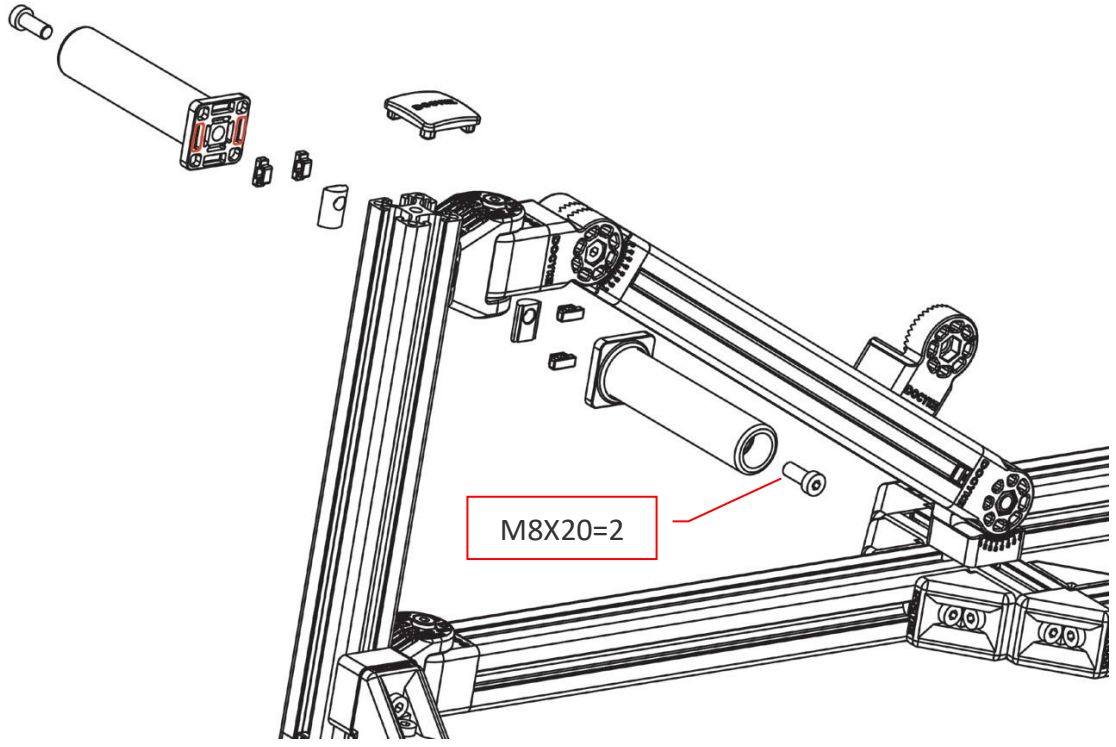

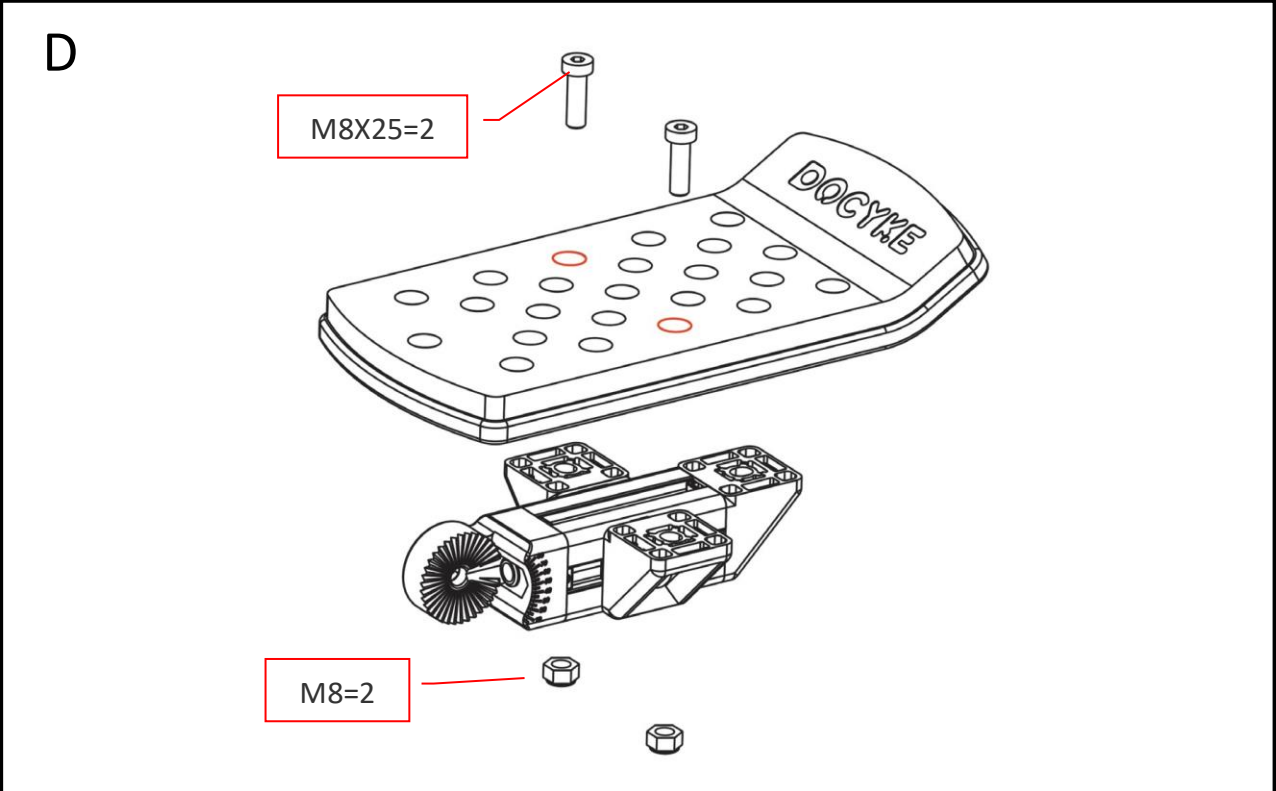
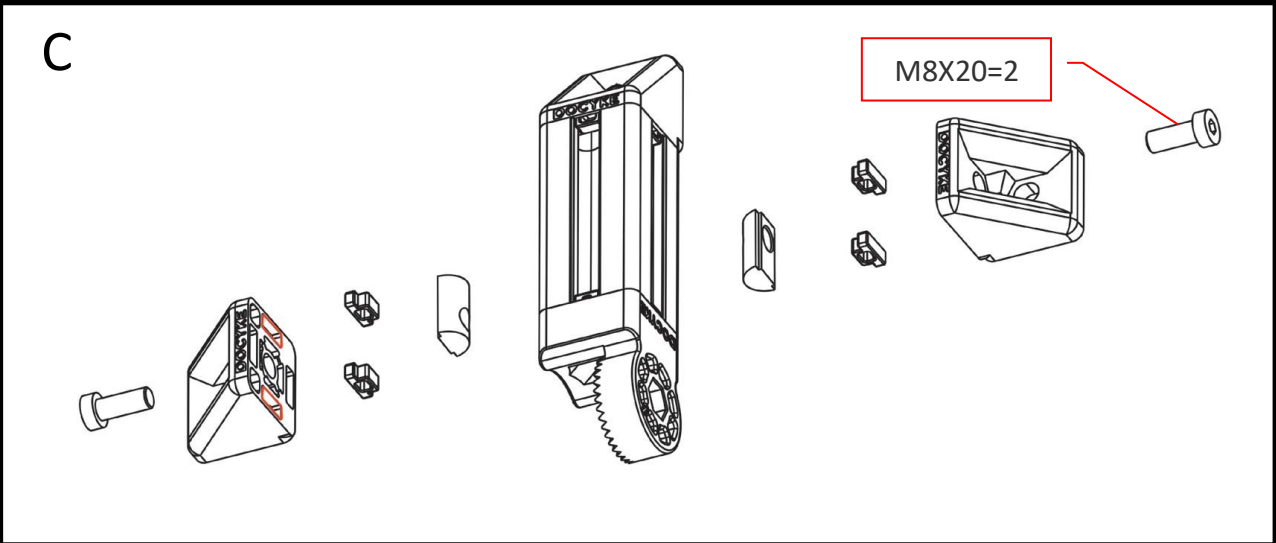
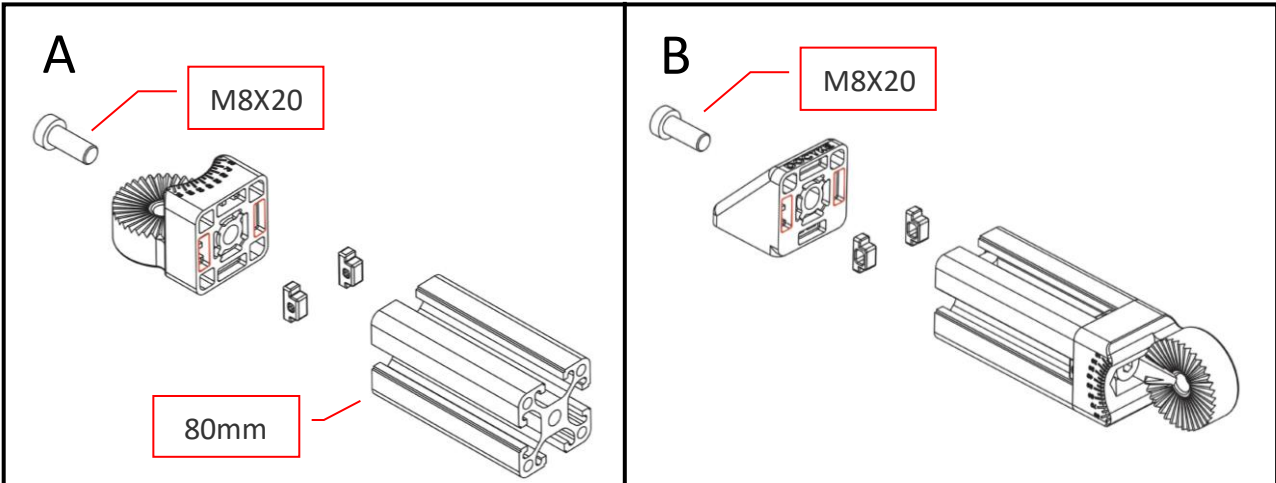

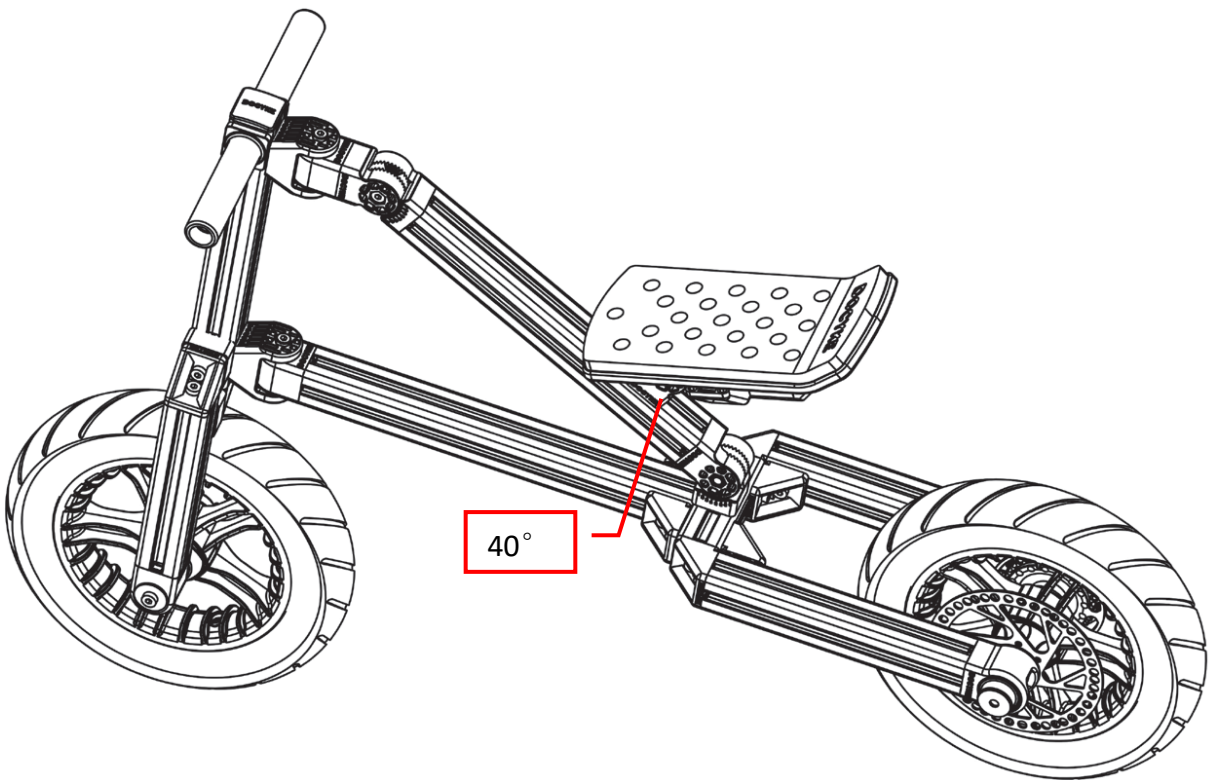
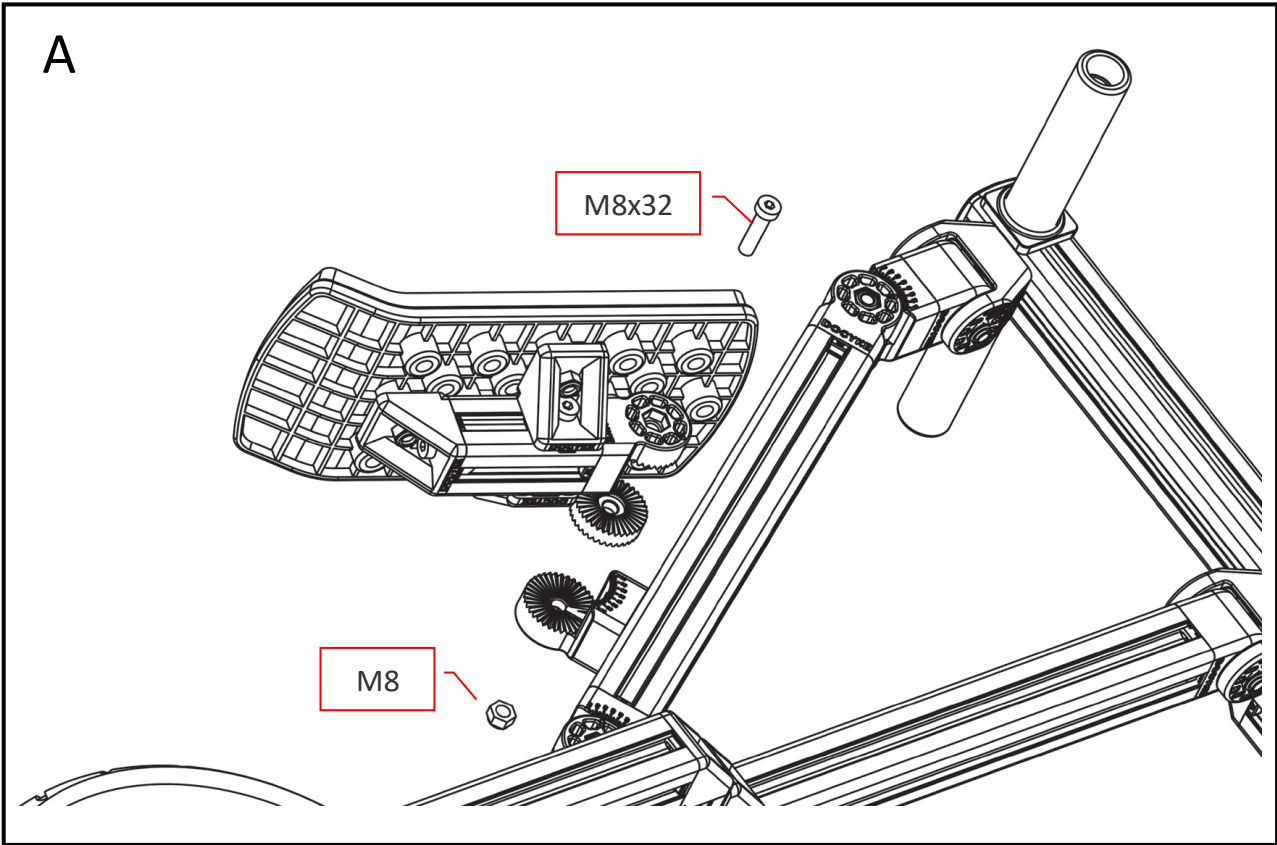

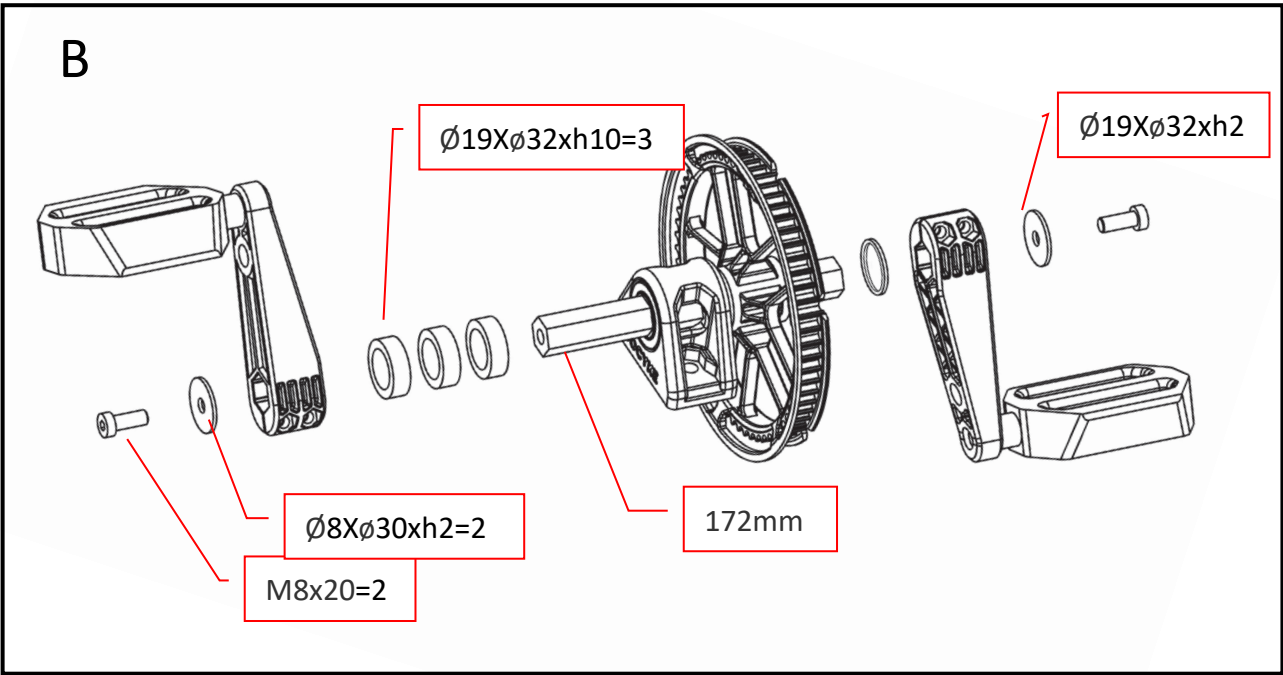
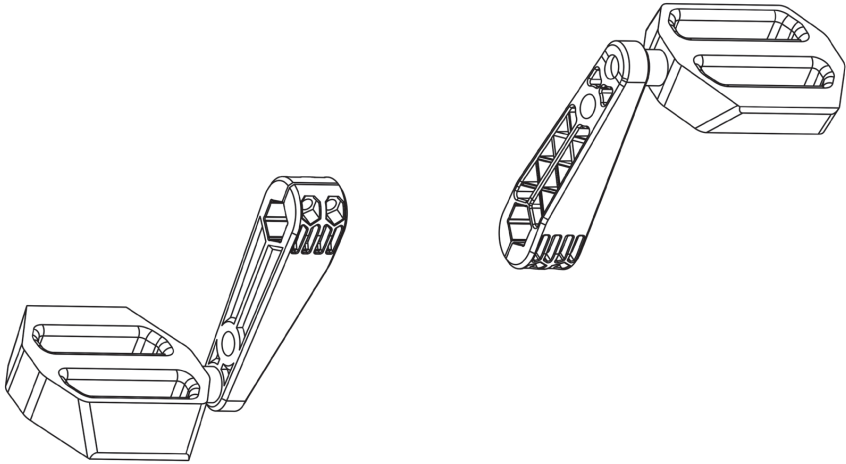
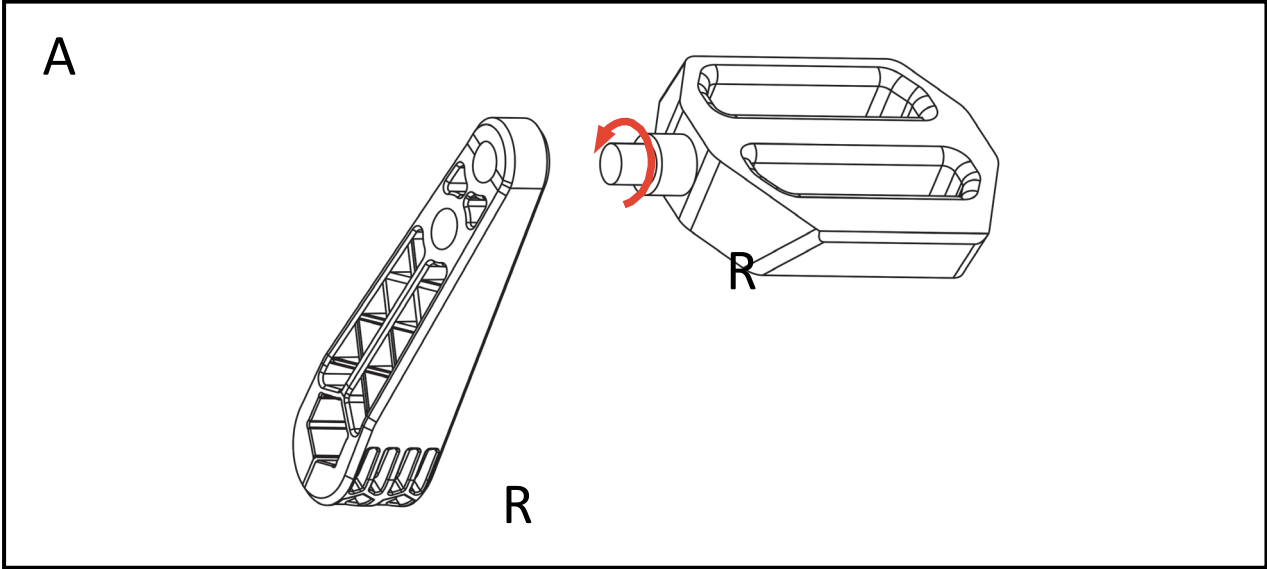

C

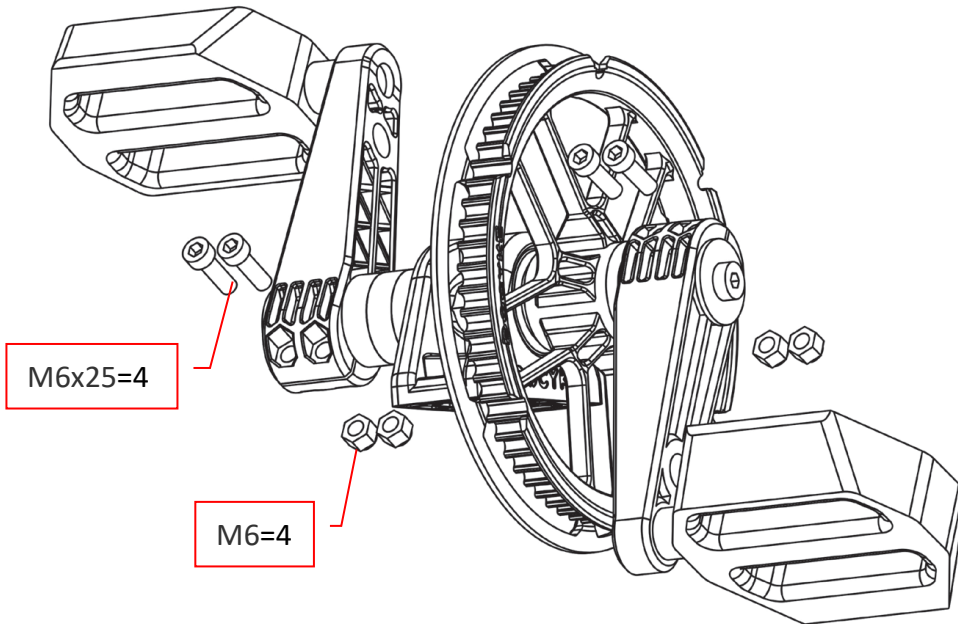

D

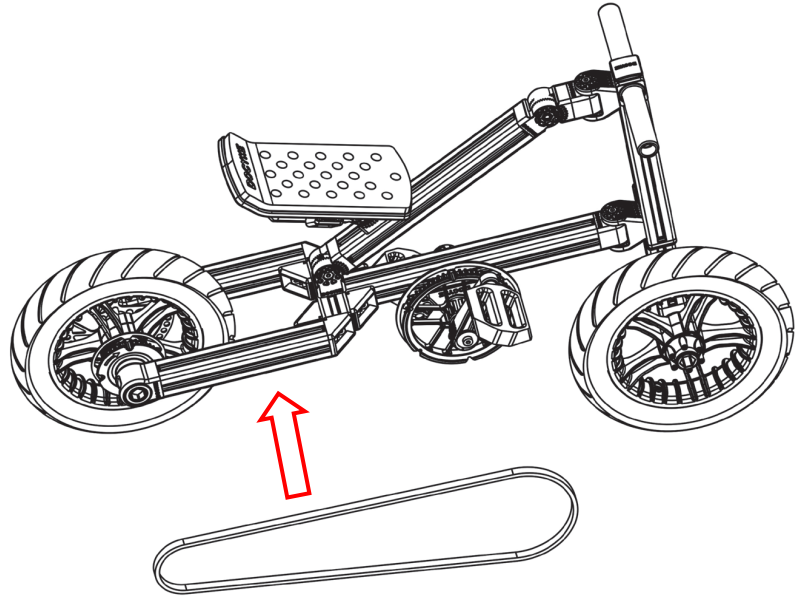
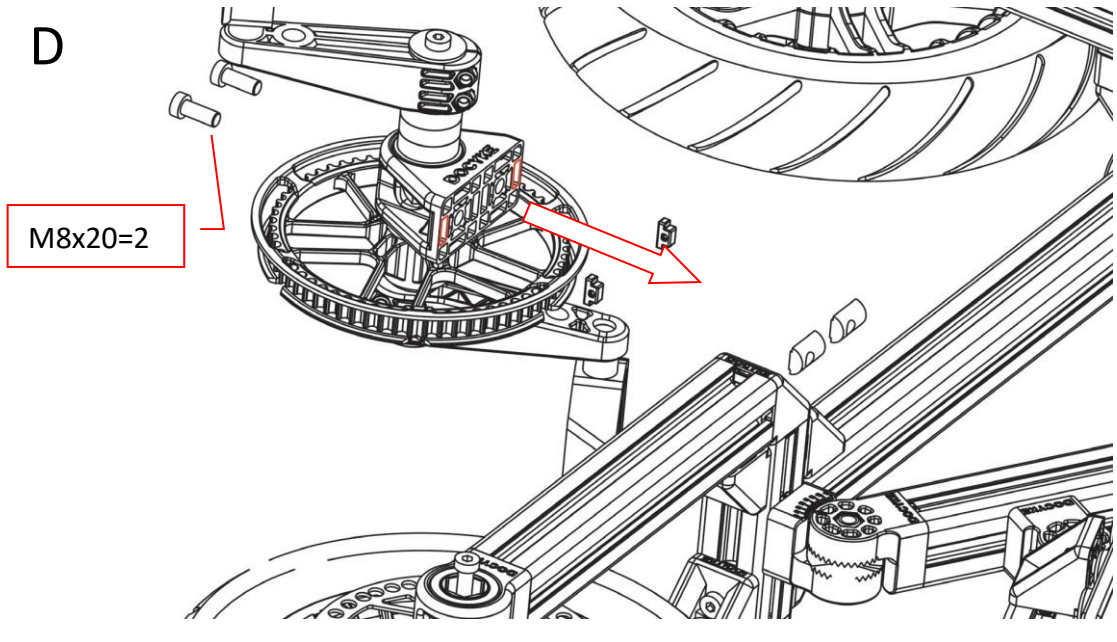

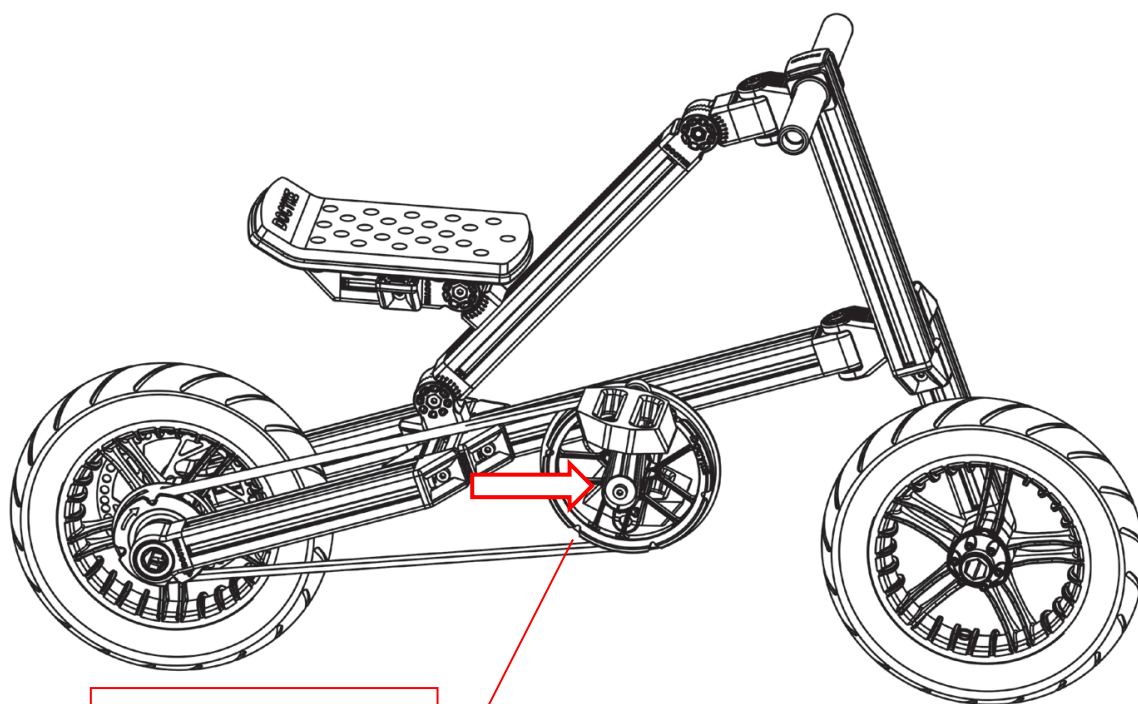

橡胶链条拉紧后再用螺丝拧紧。
Tensioned with full force,
then tighten bolts well

18

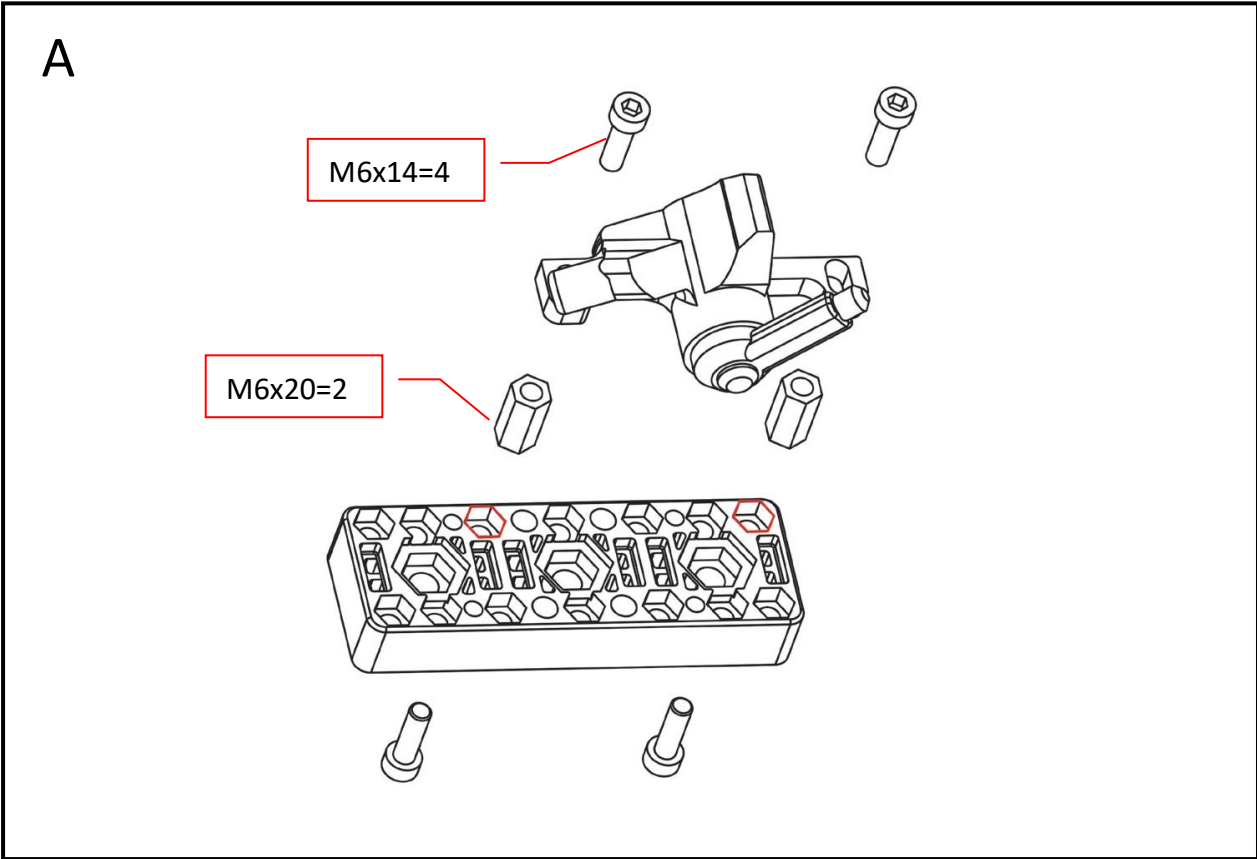

B

M8x20=2

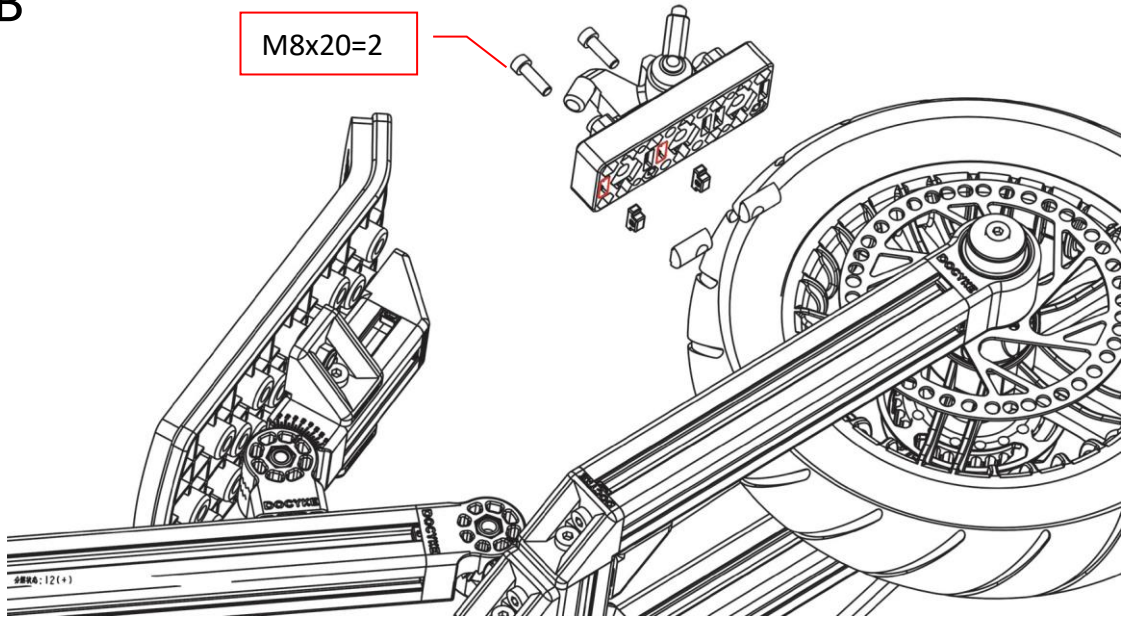

调整刹车片与刹车之间的间隙，
并拧紧螺丝。

Adjust the gap between the
brake disc and the brakes then
tighten the screws.

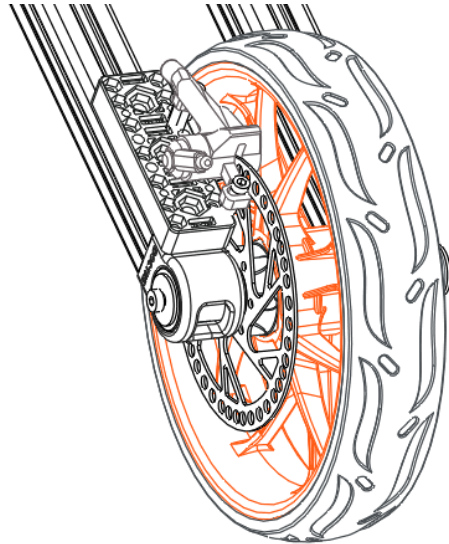

C

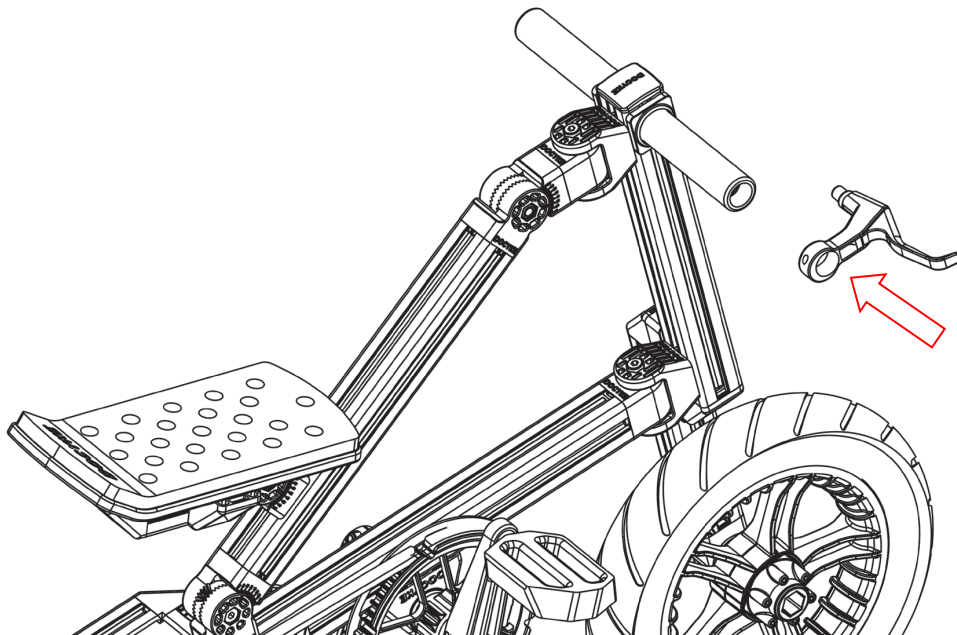

D

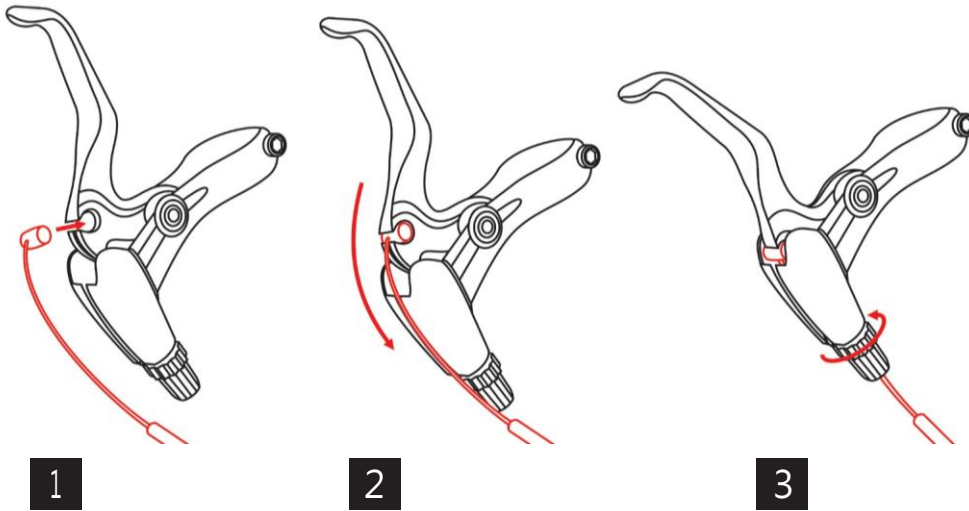

E

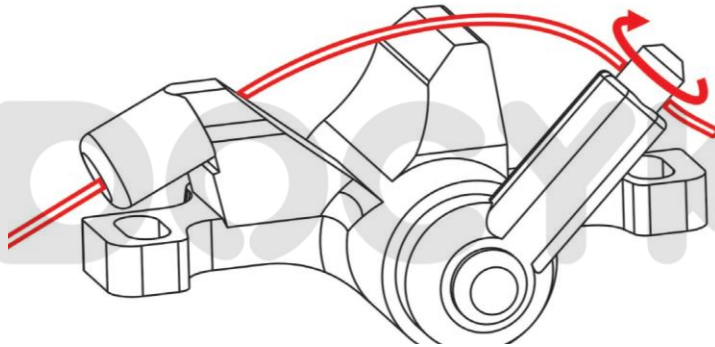

19

A

1200mm

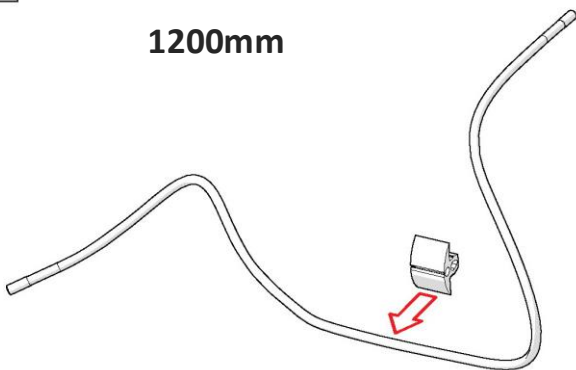

B

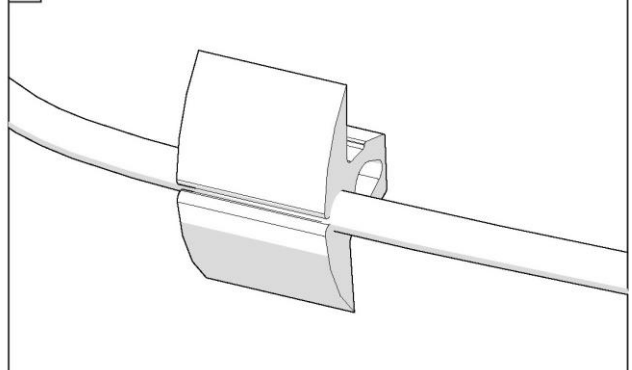

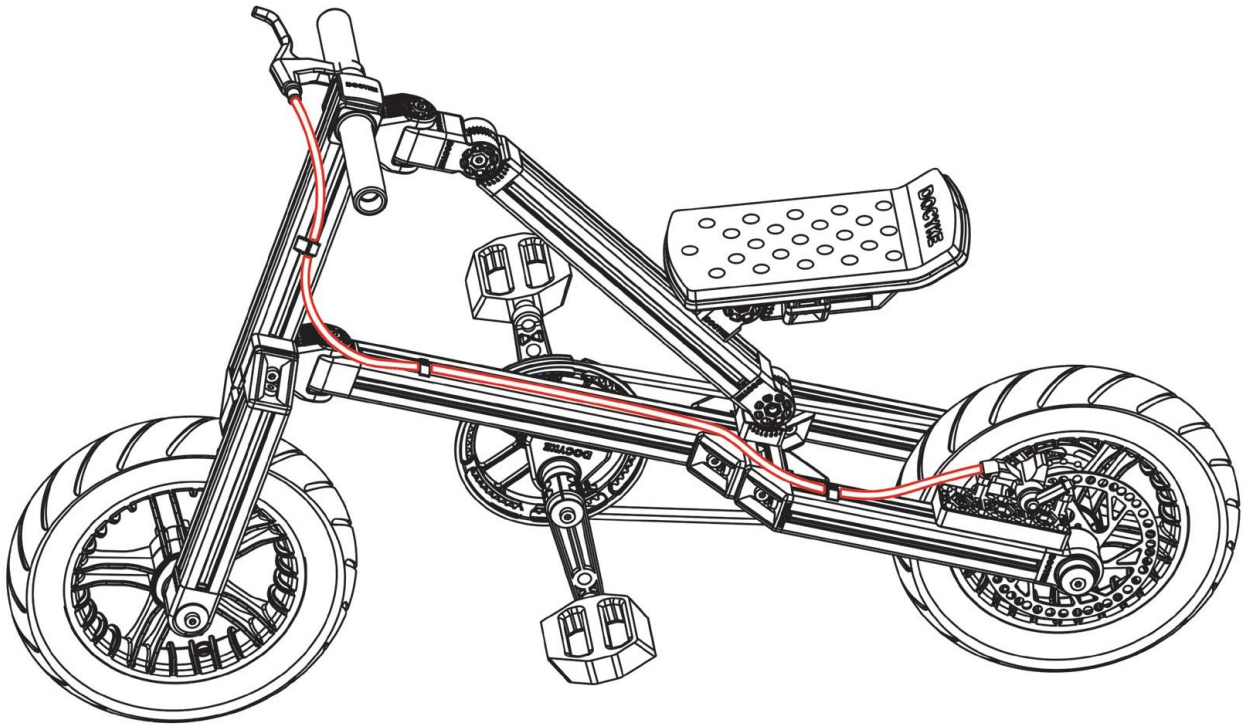

如果您有任何问题，或者更好，更酷的创意，欢迎联系我们。

If you have any questions or better ideas, welcome to contact us.

do@docyke.com