

Weather Station

(Save the Instructions For Future Reference)

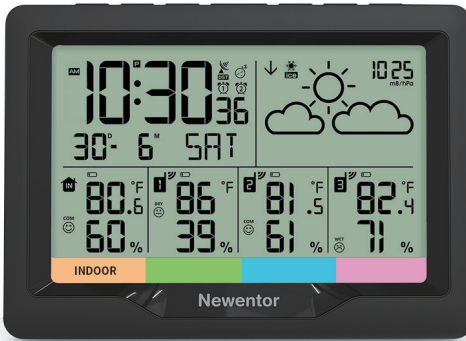

Email
service@newentor.com



Facebook
Search: Newentor



WhatsApp
[+8613410031201](https://wa.me/+8613410031201)



Telegram
NEWENTOR

Weather station is a functional product, if you have any questions of using it, contact us through above ways to get support.

TABLE OF CONTENTS

1. WEATHER STATION FEATURES

1.1 Package List	2
1.2 Appearance Description	3
1.3 Button Function	5

2. INITIAL OPERATION

6

3. TIME SETTING

3.1 Set Time Manually	7
3.2 Set Time Automatically	8

4. ALARM CLOCKS

4.1 Setting the Daily Alarms	9
4.2 Switching OFF the Alarm Signal	9
4.3 Snooze Function	10

5. QUERY MAXIMUM/MINIMUM NUMERICAL VALUE ..

10

6. °C/°F UNIT TRANSFER

10

7. ICE ALERT

11

8. WEATHER FORECAST FUNCTION

11

9. COMFORT LEVEL

12

10. BAROMETRIC PRESSURE TREND DISPLAY

12

11. BACKGROUND LIGHTING

12

12. LOW BATTERY INDICATE



13

13. PRODUCT SPECIFICATION

13

WEATHER STATION FEATURES

1.1 Package List

ITEM NO	PART NAME	FIGURE	QTY																		
1	Weather Station		1																		
2	Outside Sensor		3																		
3	Stickers	<table border="0"> <tr> <td>Garden</td> <td>Balcony</td> <td>Workshop</td> </tr> <tr> <td>Kid's Room</td> <td>Living Room</td> <td>Basement</td> </tr> <tr> <td>Porch</td> <td>Dining Room</td> <td>Kitchen</td> </tr> <tr> <td>Outside</td> <td>Apartment</td> <td>North Side</td> </tr> <tr> <td>East Side</td> <td>Baby Room</td> <td>Bedroom</td> </tr> <tr> <td>Vegetable Shed</td> <td>Chicken Coop</td> <td>Garage</td> </tr> </table>	Garden	Balcony	Workshop	Kid's Room	Living Room	Basement	Porch	Dining Room	Kitchen	Outside	Apartment	North Side	East Side	Baby Room	Bedroom	Vegetable Shed	Chicken Coop	Garage	18
Garden	Balcony	Workshop																			
Kid's Room	Living Room	Basement																			
Porch	Dining Room	Kitchen																			
Outside	Apartment	North Side																			
East Side	Baby Room	Bedroom																			
Vegetable Shed	Chicken Coop	Garage																			
4	User Manual		1																		

 The device will consume a lot of battery power when the backlight is on. Like most other black-and-white screen devices, to extend battery life, its' backlight will turn off after 15 seconds.

1.2 Appearance Description

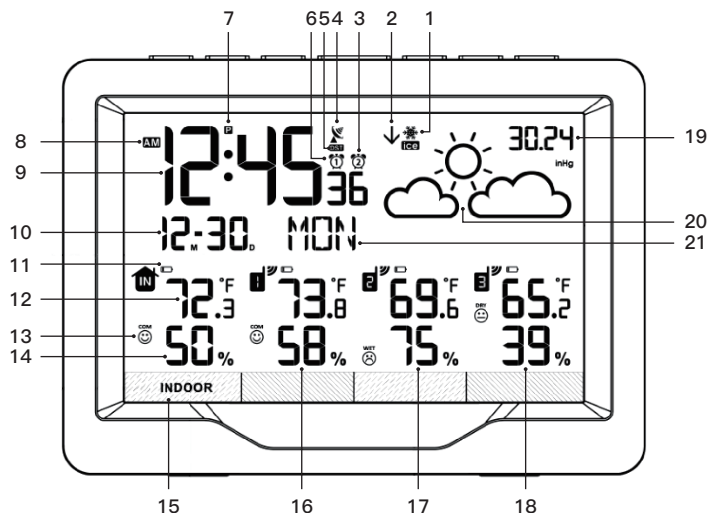

- | | |
|----------------------------------|----------------------------------|
| 1. Ice alert (☞ 11th) | 11. Battery signal (☞ 13th) |
| 2. Air pressure Trend (☞ 12th) | ▲ 12. Temperature (☞ 13th) |
| 3. Alarm clock 2 (☞ 9th) | 13. Comfort level (☞ 12th) |
| 4. WWVB searching signal (☞ 8th) | ▲ 14. Humidity (☞ 13th) |
| 5. DST (☞ 7th) | 15. Remote sensor location label |
| 6. Alarm clock 1 (☞ 9th) | 16. Remote sensor 1 data (☞ 6th) |
| ▲ 7. Time zone (☞ 7th) | 17. Remote sensor 2 data (☞ 6th) |
| 8. AM/PM (☞ 7th) | 18. Remote sensor 3 data (☞ 6th) |
| 9. Time (☞ 7th) | 19. Current Air pressure (☞ 7th) |
| 10. Date/Month (☞ 7th) | 20. Weather forecast (☞ 11th) |
| | 21. Week (☞ 7th) |

- ▲ 7. Choose correct time zone (P, M, C, E) to set time correctly.
- ▲ 12. There is 1°C deviation when temperature is 0°C~40°C, while 2°C in -9.9°C~0°C or 40°C~50°C.
- ▲ 14. There is 5% deviation when humidity is 40%~80%, while 8% deviation in 20%~40% or 80%~95%.

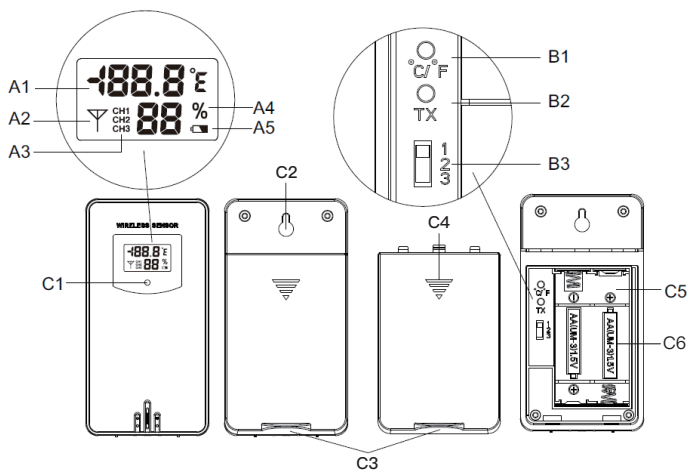

A1: Remote sensor temperature

A2: Emission symbols

A3: Channel number

A4: Remote sensor humidity

A5: Remote sensor low battery indicate (👉 12th)

B1: °C /°F unit transfer button

B2: Manual transmitter button

B3: Channel switch

C1: Transmit indicating lamp

C2: Wall mounting hole

C3: Stand cover

C4: Battery compartment cover

C5: Battery compartment

C6: Remote sensor battery

! To make sure your remote sensor more accurate, put it away from direct rain, sunny or close to the place where will affect the sense result.

1.3 Button Function

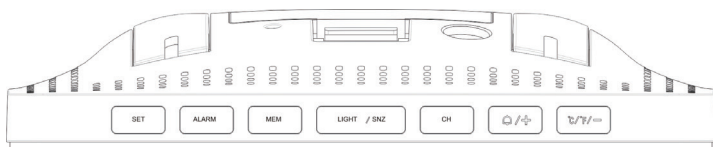

Button		SET	ALARM	MEN	LIGHT /SNZ	CH	□/+	°C/°F/-
Function								
Normal Mode	Press	/	Alarm time display	MAX/MIN temperature & humidity	Wake up backlight for 15s	Select channel	Turn on/off alarm 1/2	°C/°F Switch
	Hold	Time Setting	Set Alarm time	Re-record MAX/MIN temperature & humidity	Wake up backlight for 15s	Channel searching	/	Start/-cancel WWVB searching
Time Setting	Press	Confirm and go next steps	/	/	/	/	Increase	Decrease
	Hold	/	/	/	/	/	Increase Continuously	Increase Continuously
Alarm Setting	Press	/	Confirm and go next steps	/	/	/	Increase	Decrease
	Hold	/	/	/	/	/	Increase Continuously	Increase Continuously
Alarm Clock Goes Off	Press	Turn off the alarm	Turn off the alarm	Turn off the alarm	Snooze mode	Turn off the alarm	Turn off the alarm	Turn off the alarm
	Hold	/	/	/	/	/	/	/

02 INITIAL OPERATION

- Open the Weather Station battery compartment cover.
- Insert 2 x AA batteries observing polarity [**⊕/+**] and [**°C/°F/-**] marks].
- When you insert the batteries, all icons on the LCD will light up for 3 seconds, and you will hear a beep tone, then detect indoor temperature & humidity.
- The Weather Station will start to make a connection to the outdoor remote sensor. This process lasts for a maximum of 3 minutes and will be displayed by a flashing reception antenna symbol  in the "OUTDOOR" display area on the receiver.
- Open the remote sensor battery compartment cover, push the channel switch to the "1" position, insert 2 x AA batteries observing polarity [**⊕/+**] and [**°C/°F/-**] marks], press "TX" button of remote sensor at the same time to connect main unit, close the battery cover.
- According to the same method, push the channel of remote sensor switch to the "2" or "3" position to connect main unit.
- After receiver has created 3 remote sensor connections, it will enter the Radio control receive mode.

F.Y.I

- If the Weather Station failed to receive transmission from outdoor remote sensor ("--" display on the LCD), press the **[CH]** button to select the channel, the number of selected channel will flash, then press and hold the **[CH]** button for 3 seconds, RF icon  will be flashing, the weather station will reconnect the launch signal of the channel.

- ⚠ There is 1°C deviation when temperature is 0°C~40°C, while 2°C in -40°C~0°C or 40°C~70°C.
- ⚠ There is 5% deviation when humidity is 40%~80%, while 8% deviation in 20%~40% or 80%~95%.

3.1 Set Time Manually

- Press and hold the **[SET]** button for 2 seconds, the “ ON/OFF ” starts to flash. Now use **[Q/+]** and **[°C/°F/-]** buttons to set the radio control function ON or OFF.
- Press **[SET]** button to confirm your setting, the 12/24HR start to flash. Now use **[Q/+]** and **[°C/°F/-]** buttons to set the 12/24 hour mode you need.
- Press **[SET]** to confirm your setting, the Time Zone start to flash, Now use **[Q/+]** and **[°C/°F/-]** buttons set a correct time zone (P/M/C/E).
- Press **[SET]** to confirm your setting, the “DST ON/OFF” start to flash, Now use **[Q/+]** and **[°C/°F/-]** buttons set the DST ON or OFF.
- Press **[SET]** to confirm your setting, the Hour starts to flash. Now use **[Q/+]** and **[°C/°F/-]** buttons to set the correct hour.
- Press **[SET]** to confirm your setting, the Minute starts to flash. Now use **[Q/+]** and **[°C/°F/-]** buttons to set the correct minute.
- Press **[SET]** to confirm your setting, the Month and Date icon starts to flash. Now use **[Q/+]** and **[°C/°F/-]** buttons to select date display on Month/Date or Date/Month.
- Press **[SET]** to confirm your setting, the Year is display and starts to flash. Now use **[Q/+]** and **[°C/°F/-]** buttons to set the correct year.
- Press **[SET]** button to confirm your setting, the Month starts to flash. Now use **[Q/+]** and **[°C/°F/-]** buttons to set the correct month.
- Press **[SET]** button to confirm your setting, the Date starts to flash. Now use **[Q/+]** and **[°C/°F/-]** buttons to set the correct date.
- Press **[SET]** button to confirm your setting, the Weather forecast Pattern starts to flash. Now use **[Q/+]** and **[°C/°F/-]** buttons to select the current weather pattern.
- Press **[SET]** button to confirm your setting, the Air Pressure Unit will display and starts to flash. Now use **[Q/+]** and **[°C/°F/-]** buttons to choose the air pressure unit you need.
- Press **[SET]** button to confirm your setting, the Air Pressure Value starts to flash. Now use **[Q/+]** and **[°C/°F/-]** buttons set to local standard pressure value.
- Press **[SET]** button to confirm your setting and to end the setting procedures, then it will return to the normal mode.

F.Y.I.

- If there is no valid operation within 20 seconds, it will automatically return to normal time mode from the set mode.
- When adjusting the value, press and hold the **[\odot /+]** or **[°C/°F/-]** key to adjust continuously and quickly.

3.2 Set Time Automatically

- The clock will automatically search the **WWVB** signal after 3 minutes of any restart or changing of new fresh batteries. Before searching **WWVB**, please set a correct Time Zone according to your location. When searching for **WWVB**, the radio mast icon  will flash.
- At 1:00 /2:00 / 3:00 AM, the clock automatically carries out the synchronization procedure with the **WWVB** signal to correct any deviations to the exact time. If fail, the radio mast icon will disappear, the system will automatically attempt another synchronization at the next full one hour. This procedure will be repeated automatically up to total 5 times.
- To start manual **WWVB** signal reception, choose a correct Time Zone first, then leave it alone until it return to the normal mode. Press **[°C/°F/-]** button for 3 seconds to start searching **WWVB**, the time and date will be set correctly after searching. If no signals received within 7 minutes, the **WWVB** signal search will stop (the radio mast icon disappears) and start again at the next full one hour.
- During RC reception, Press **[°C/°F/-]** button can stop searching **WWVB** signal.

F.Y.I.

- A flashing radio mast icon indicates that the **WWVB** signal reception has started.
- A continuously displayed radio mast icon indicates that the **WWVB** signal was received successfully.
- We recommend Placing weather station at a minimum distance of 2.5 meters (8.2Feet) to all sources of interference, such as televisions or computer monitors or switching power adapter.
- Radio reception is weaker in rooms with concrete walls (e.g.: in cellars) and in offices. In such extreme circumstances, place the weather station close to the window.
- During the RC receive mode, only the **[Light/SNZ]** and **[°C/°F/-]** buttons have a function, other buttons are not functional. If you want to carry out other functions of operation, please press **[°C/°F/-]** button to exit the RC receiving mode.

4.1 Setting the Daily Alarms

- Press once **[Q/+]** button, LCD will display **①**, press again to display **②**, press again to display **①②**, each to represent Alarm1 ON (Alarm2 OFF), Alarm2 ON (Alarm1 OFF), Alarm1&Alarm2 ON. Press **[Q/+]** button again to Alarm1 and Alarm2 all OFF (no “**①**” and “**②**” display).
- Press once **[ALARM]** button, LCD display alarm1 time, press **[ALARM]** button again, LCD display alarm2 time, press **[ALARM]** button again, return to time display.
- Press and hold ALARM button for 3 seconds, until the Hour of the Alarm1 time starts to flash. Use the **[Q/+]** and **[°C/°F/-]** buttons to set the required hour.
- Press **[ALARM]** button to confirm your setting, the Minute of the Alarm1 time starts to flash. Use the **[Q/+]** and **[°C/°F/-]** buttons to set the required minute.
- Press **[ALARM]** button to confirm your setting, the Hour of the Alarm2 time starts to flash. Use the **[Q/+]** and **[°C/°F/-]** buttons to set the required hour.
- Press **[ALARM]** button to confirm your setting, the Minute of the Alarm2 time starts to flash. Use the **[Q/+]** and **[°C/°F/-]** buttons to set the required Minute.
- Press **[ALARM]** button to confirm your setting and end the setting procedure.

F.Y.I.

- If there is no valid operation within 20 seconds, it will automatically return to normal time mode from the alarm time setting mode.
- When adjusting the value, press and hold the **[Q/+]** or **[°C/°F/-]** key to adjust continuously and quickly.
- The alarm will sound for 2 minutes if you do not deactivate it by pressing any button. In this case the alarm will be repeated automatically after 24 hours.
- Rising alarm sound (crescendo) changes the volume 4 times whilst the alarm signal is heard.

4.2 Switching OFF the Alarm Signal

- When the alarm is ringing, press any button except the **[Light/SNZ]** button to stop the alarm signal. It is not necessary to reactivate the alarm. It will ring again this time next day.

4.3 Snooze Function

- When the alarm is ringing, press the **[Light/SNZ]** button the alarm mode will to get to snooze mode. The alarm signal sounds again after 8 minutes.

05 Query Maximum/minimum numerical value

- When the temperature / humidity are shown in the LCD, the weather station begins to record temperature/humidity maximum and minimum numerical value.
- Press **[MEM]** button, the LCD will display the maximum value of temperature/ humidity. Press **[MEM]** button again, the LCD will display the minimum value of temperature/humidity.
- At the same time, there are “MAX” or “MIN” displayed on the LCD.
- The temperature/humidity maximum/minimum value will re-record when press and hold **[MEM]** button 3 seconds.
- The memory value of the day will be automatically cleared at every 0:00 am.

F.Y.I.

- If the temperature reading is below the measuring range, the **LL.L** will be displayed. If the temperature reading is above the measuring range, the **HH.H** will be displayed.

06 °C /°F UNIT TRANSFER













- Press the **[°C/°F/–]** button to select °C or °F units.

07 ICE ALERT

- The ice alert symbol will appear and flash when the outdoor temperature at -1°C to $+3^{\circ}\text{C}$ or $+30.2^{\circ}\text{F}$ to $+37.4^{\circ}\text{F}$.

08 WEATHER FORECAST FUNCTION

- The weather symbols indicate the weather fluctuation over the next 6–12 hours, not the current weather.
- Please take the weather forecast from your local weather forecasting service into account as well as the forecast from your weather station. If there are discrepancies between the information from your device and from the local weather forecasting service, please take the advice of the latter as authoritative.
- The weather forecast is calculated from evaluation of fluctuations in the barometric pressure and may deviate from the actual weather conditions.
- The weather station displays the following weather symbols:

Sunny			----
Slightly cloudy			----
Cloudy		----	----
Rainy			----
Heavy rainy			
Snowy			

09 COMFORT LEVEL

- ☹️ The temperature and humidity is dry (When the humidity is below 40%).
- 😊 The temperature and humidity is comfort (When the temperature in 20~28°C and the humidity is 40~70%).
- ☹️ The temperature and humidity is wet (When the humidity is above 70%).

F.Y.I.

When the temperature is not 20~28°C and the humidity is 40~70%, the comfort level icon will not be displayed.

10 BAROMETRIC PRESSURE TREND DISPLAY

↑ The barometric pressure is rising more than 2 hPa.

↓ The barometric pressure is dropping more than 2 hPa.

If there is no arrow trend, it means the barometric pressure does not change more than 2 hPa in 1 hour.



11 BACKGROUND LIGHTING

- Press the **[Light/SNZ]** button, the backlight will light up for 15 seconds.



LOW BATTERY INDICATE

- If the battery icon “” appears , the batteries in the outdoor sensor should be replaced as soon as possible.



PRODUCT SPECIFICATION

- LCD screen size: 5.2 inches x 3.5 inches
- Perpetual Calendar up to year 2099
- Humidity: Indoor & Outdoor measurement range: 20%RH~95%RH (5% deviation)
- Temperature measurement range (1°C deviation) :
 - Indoor: -9.9°C(14.2°F)~50°C(122°F)
 - Outdoor: -25°C(-13°F)~50°C(122°F)
- Wireless Outdoor Sensor:
 - 433.92MHz RF transmitting frequency
 - 60m/200ft transmission rang in an open area
- Power Supply:
 - Weather Station: Battery: 2 x LR06AA (Not including)
 - Wireless Outdoor Sensor: 2 x LR06AA (Not including)