

USER MANUAL

HIBOY S11 Electric Skateboard



HIBOY

Contents

1.Packing List -----	01
2.Safety Notice -----	02
3.Product Overview -----	04
4.First Time Remote Connection -----	06
5.Check Board Battery -----	07
6.Check Remote Battery -----	08
7.Change Accelerate/Brake Mode -----	09
8.Riding Notice -----	10
9.Specifications -----	12
10.Daily Care and Maintenance -----	13
11.Service and Warranty -----	15
12.Contact -----	16

Packing List

Thanks for choosing Hiboy Electric Skateboard S11 (hereinafter referred to as Hiboy S11). To enjoy the many features of your Hiboy S11 you must read and follow these instructions. Have fun and enjoy your ride!

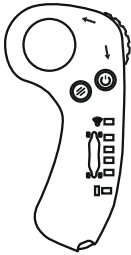

Remote

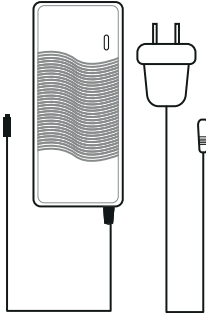

Charger

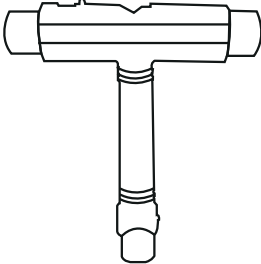

Tool key



Cable

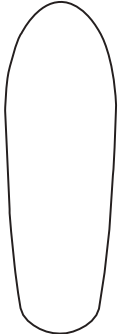

Board

Precautions

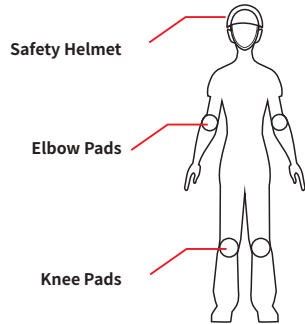

WARNING

Wear safety gear and read this paper carefully before driving. In low Battery state, it will automatically switch to protected mode.

No high speed and high acceleration in low battery status. Before Using board, make sure that the Hiboy S11 is fully charged.

Pay attention to the surrounding environment, ride on the safety road possible
Please comply with local laws and regulations and use it in places where allowed.

Safety Notice

1. The electric skateboard has been designed as a recreational product. Before mastering riding skills, you need to practice. Hiboy is not responsible for any injuries or damage caused by a rider's inexperience or failure to follow the instructions in this document.
2. Please understand that you can reduce the risk by following all the instructions and warnings in this manual, but you cannot eliminate all the risks. Remember that whenever you ride the electric skateboard you risk injury or death from loss of control, collisions, and falls. When entering into public spaces always comply with the local laws and regulations. As with other vehicles, faster speeds require longer braking distance. Sudden braking on smooth surfaces could lead to wheel slip, loss of balance, or falls. Be cautious and always keep a safe distance between you and other people or vehicles when riding. Be alert and slow down when entering unfamiliar areas. Users are responsible for following all local, state, and federal laws regarding the use of this product.
3. Always wear a helmet when riding. Use an approved bicycle or skateboard helmet that fits properly with the chin strap in place, and provides protection for the back of your head. follow the instructions in this document.

4. Do not attempt your first ride in any area where you might encounter children, pedestrians, pets, vehicles, bicycles, or other obstacles and potential hazards.

5. PARENTAL/ADULT SUPERVISION IS NECESSARY WITH CHILDREN UNDER 12. If you are under 18, please get your parent's permission.

6. The electric skateboard is not for users weighing less than 44lbs than 44lbs/20kg or more than 220lbs/100kg. The maximum weight limit of 220 lbs (100 kg) includes items that might be worn or carried such as backpacks, clothes, or personal items. Failure to adhere to the minimum and maximum weight limits can cause personal injury to the user and damage to the electric skateboard. Meeting the weight restrictions does not necessarily mean the person is the appropriate size for fitting on, operating, riding, and controlling the device.

7. Do not allow anyone to ride your electric skateboard on his/her own unless they have carefully read this manual. The safety of new riders is your responsibility. Assist new riders until they are comfortable with the basic operation of the electric skateboard. Make sure each new rider wears a helmet and other protective gear.

8. Before each ride check for loose fasteners, damaged components, and hub motor. If the electric skateboard makes abnormal sounds or signals an alarm, immediately stop riding.

9. Never ride at high speeds on uneven terrain or slopes. Never ride in the dark, or dimly lit areas. Do not ride in the snow, in the rain, or on roads which are wet, muddy, icy, or that are slippery for any reason. Do not ride over obstacles (sand, loose gravel, or sticks). Doing so could result in a loss of balance or traction and could cause a fall. Never ride backward for long distances or at high speeds.

10. Use a surge protector when charging to help protect your electric skateboard from damage due to power surges and voltage spikes. Only use the originally supplied charger. Do not use a charger from any other product.

Product Overview

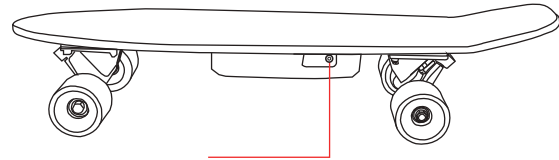
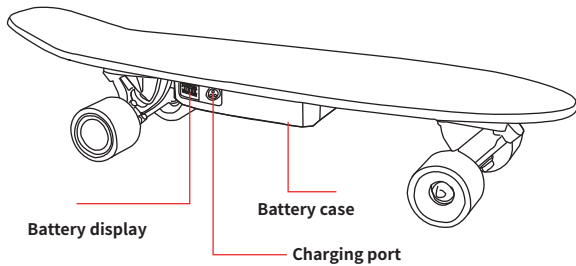

Power button

WARNING

Don't move board until the beeps end (in first 5 seconds after the boot).

Remote

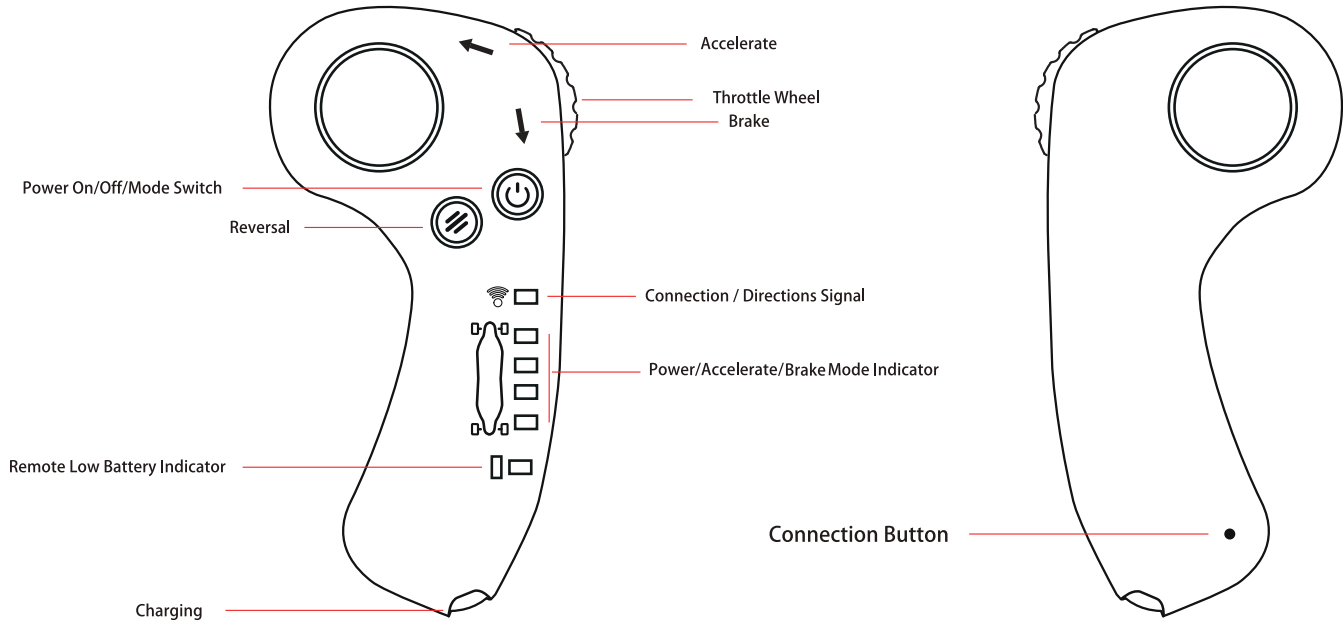

First Time Remote Connection

1. Press the Power button both on board and remote.
The connection signal on remote would turn green(Keeps).
2. Press power button on board for 10s and the blue indicator would be flash, use a needle to press the Connection Button on the remote.
3. Connection Signal turn to flash means connect successfully.

Notice: Your board and remote have already been paired prior to shipping, so you typically only need to do this when pairing to a new board or remote.

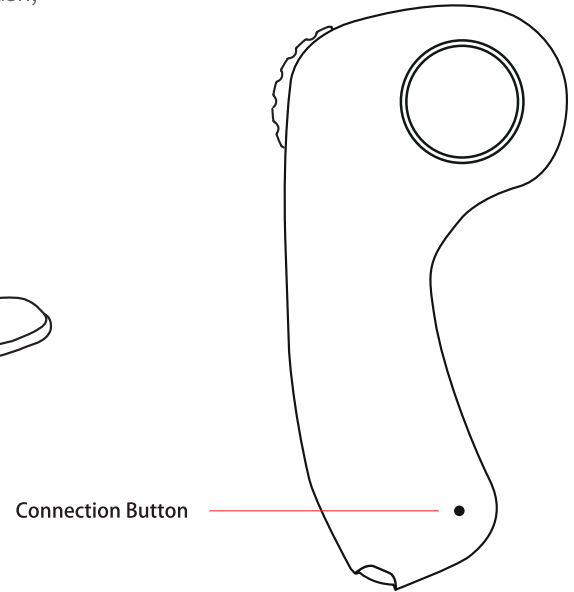
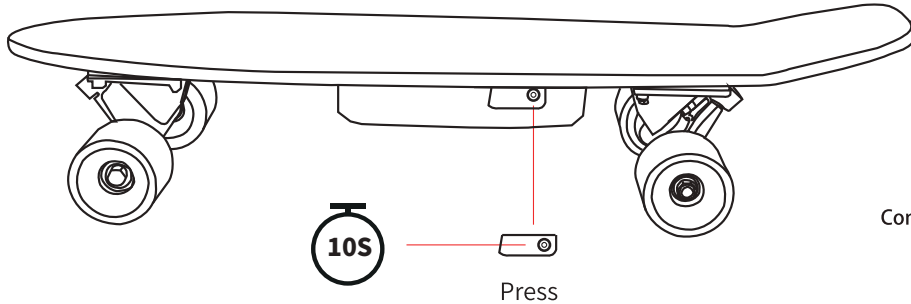

Check Board Battery

1. From the Remote

When the remote connected, the Power/Accelerate/Brake Mode Indicator will indicate the power level.

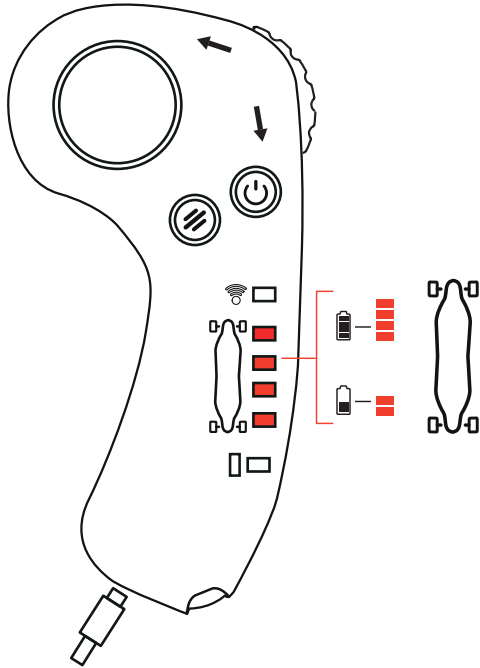

2. From the Board

When the board is on, the battery lights will indicate the power level.

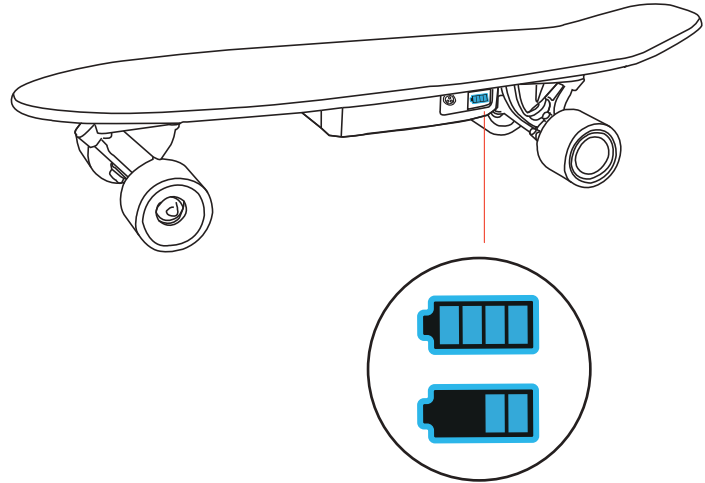

Checking Remote Battery

1. When the remote is connecting, the Power/Accelerate/Brake Mode Indicator will flash to show the remote battery level.

2. Remote Low Battery Indicator would light up if the remote battery is low.

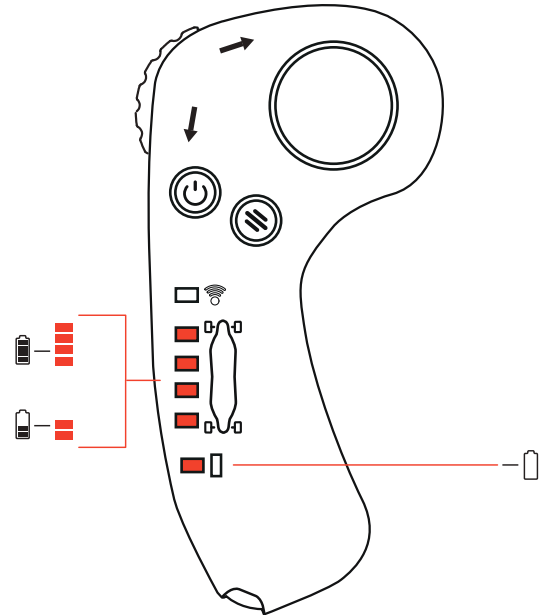

Changing Accelerate /Brake Mode

This board ships in Beginner Mode. Before following the instructions below to switch modes, make sure you have mastered the use of the remote and board.

Beginner: limited acceleration/brake/top speed, no hills.
Skillful: moderate acceleration/brake/top speed, no hills.
Expert: high acceleration/brake/top speed, small hills.
Master: extreme acceleration/brake/top speed, small hills.



WARNING

The Throttle Wheel is much more sensitive in Expert Mode and Master Mode.

To Change Modes

Come to a full stop. Tap the Power Button 1 time rapidly to change acceleration modes. Roll the throttle wheel to the brake end and tap the Power Button 1 time rapidly to change brake modes. Power/Accelerate/Brake Mode Indicator would light 3s to identify which mode you are in.

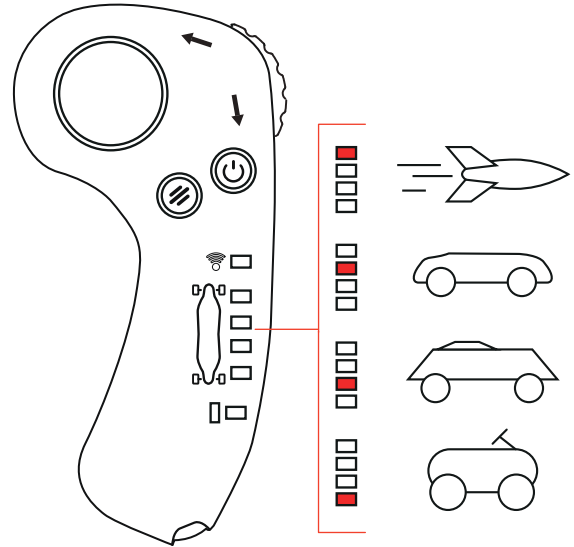

Riding Notice

Stance

Your Hiboy S11 board has a lot of power. Follow these tips to ensure a safe riding experience:

- Keep a wide stance on the board.
- Keep a low center of gravity.
- Move the Throttle Wheel in small increments.
- Lean forward when accelerating.
- Lean backwards when braking.

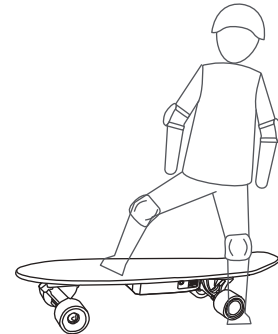
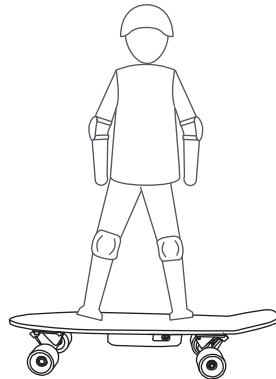
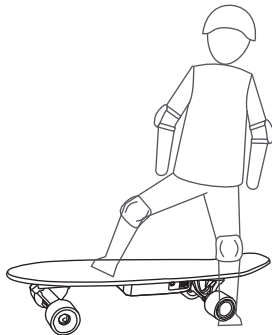

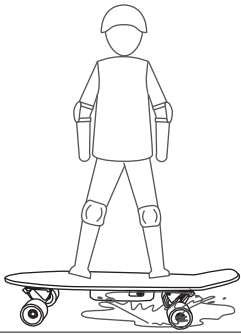

WARNING
Do not ride through puddles or other bodies of water. Do not ride rainy days.

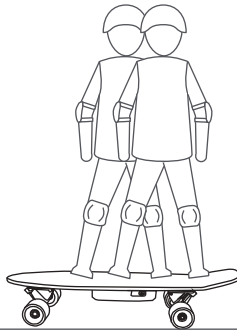

WARNING
Do not ride double or carry any passengers.

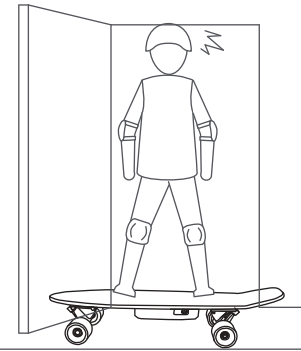

WARNING
Watch your head when passing through doorways.



WARNING
Do not ride with high heels. Always ride with properly strapped closed toe shoes.

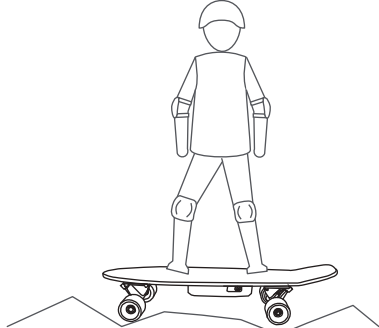

WARNING
When traversing small bumps or uneven terrain, maintain a moderate speed and keep your knees bent.

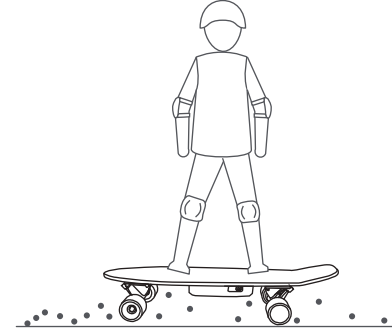

WARNING
Do not ride on low traction surfaces (including, but not limited to, wet ground, loose sand, loose gravel, and ice).

Specifications

Electric Skateboard	N.W	7.94lbs (3.6kg)
	Size	29.2×7.8×5.6 in (740*200*140mm)
	Range	6.2-9.3miles
	Operating Temperature Range	14–104°F (-10–40°C)
	Board Material	7 layers maple
	Max Weight Capacity	220 lbs(100kg)
	Top speed	12.4mi/h (20km/h)
Battery	Capacity	4Ah
	Types	25.2V lithium battery
	Charging Duration	3-4h
	Charging Times	Above 500 times
Motor &Wheel	Type	70MM hub motor
	Wheel size	2.8*2.0in (70*51mm)
	Power	350W
Package	Size	31*10*8in (790*260*200mm)
	G.W	10.1lb(4.6kg)

The mileage and driving speed are related to the weight of the user, the ambient temperature during use, riding style and road conditions.

The range is measured in a flat road environment, under 25 ° C, 70 kg load, about 15km/h uniform speed

Daily Care and Maintenance

Cleaning and storage

If you see stains on the board body, wipe them off with a damp cloth. If the stains won't scrub off, put on some toothpaste, and brush them with a toothbrush, then wipe them off with a damp cloth.

Notes: do not clean the board with alcohol, gasoline, kerosene or other corrosive and volatile chemical solvents to prevent dire damage. Do not wash the board with a high-pressure water spray.

During cleaning, make sure that the board's turned off, the charging cable is unplugged, and the rubber flap is closed as water leakage may result in electric shock or other major problems.

When the board not in use, keep it indoors where it is dry and cool. Do not put it outdoors for a long time.

Excessive sunlight, overheating and overcooling may accelerate the battery pack's lifespan.

Battery maintenance

1. Use original battery packs, use of other models or brands may bring about safety issues;
2. Do not touch the contacts. Do not dismantle or puncture the casing. Keep the contacts away from metal objects to prevent short circuit which may result in battery damage or even injuries and deaths;
3. Use original power adapter to avoid potential damage or fire;
4. Mishandling of used batteries may do tremendous harm to the environment. To protect natural environment, please follow local regulations to properly dispose of used batteries.
5. After every use, fully charge the battery to prolong its lifespan.

Store

1. Please try to store the Electric Skateboard in a cool and dry place between 0°C and 40°C. In extremely humid environments the interior of the Electric Skateboard may suffer condensation or even water accumulation, which may damage the battery rapidly.
2. In daily use, try to avoid recharging the Electric Skateboard after completely exhausting the battery. If the battery is low, charge it as soon as possible.
3. Please charge the Electric Skateboard every other month to preserve the battery

WARNING

Do not pierce the battery with sharp objects.

Do not use heavy objects to hit the battery.

It is forbidden to put the battery into fire or water to avoid danger or environmental pollution.

Disposal

When disposing of Electric Skateboard or batteries, they must be recycled according to the regulations and standards of each region.

Service and Warranty

1. The warranty period is consistent with the national and local warranty policy. The warranty period is calculated from the date of purchase by the user (on the basis of the date on the purchase receipt).
2. Maintenance costs beyond the warranty period and beyond the scope of the warranty only incur maintenance costs.
3. Not covered by the free warranty obligation
 - a. The product or parts that have exceeded the warranty period;
 - b. Failure or damage caused by not following the instructions for use;
 - c. Damage caused by abnormal operation and man-made or natural disasters;
 - d. Damage caused by dismantling or changing any part (such as lines) by yourself.

Warranty Period

Part Name	Warranty Period	Exception	Note
Li-ion Battery	6 months	<ol style="list-style-type: none"> 1. Damage due to long-term power lack 2. Water log 	Replacement out of warranty will be charged at cost price
Controller	12 months	<ol style="list-style-type: none"> 1. Damage by strong deliberate impact 2. Water log 	Replacement out of warranty will be charged at cost price
Motor	12 months	<ol style="list-style-type: none"> 1. Damage by strong deliberate impact 2. Water log 	Replacement out of warranty will be charged at cost price
Board Parts Tires LED Lights	Quick-wear parts are not covered by warranty		Replacement parts are not covered by warranty will be charged at cost price

Contact

Contact us if you experience issues relating to riding, maintenance and safety, or errors/faults with your Hiboy S11.

HIBOY LIMITED.

12178 4TH STREET. RANCHO CUCAMONGA. CA 91730

E-mail Service: us.support@hiboy.com



@Hiboy_Official



hiboyus



@HiboyUS

You  HiboyUS



www.hiboy.com



HIBOY

The manufacturer reserves the right to make changes to the product, and update this manual at any time.

www.hiboy.com