

HIBOY

The manufacturer reserves the right to make changes to the product,
and update this manual at any time.

HIBOY

Kids Electric Bike BK1
USER MANUAL

Contents

1.Package Contents	01
2.Product Overview	02
3.Assembly and Adjust Height	03
4.Debug Brake	04
5.Charging	05
6.Riding Basics	06
7.Riding Notice	07
8.Dangerous Actions(No Attempting!)	08
9.Daily Care and Maintenance	09
10. Specifications	10
11. Limited Warranty Statement	11

1. Package Contents

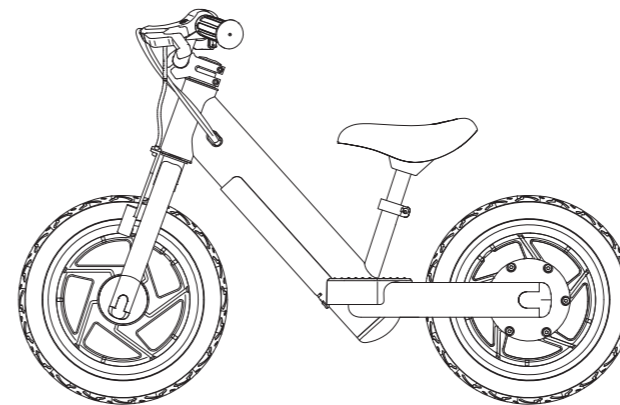

Carefully check package contents, if anything is missing or damaged, please contact Hiboy customer service for support: us.support@hiboy.com

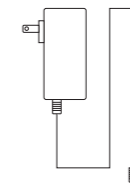

Charger x 1pcs



User manual x 1pcs



Screw x 1pcs



Spacer x 2pcs



Screw nut x 1pcs



open-end wrench x 1pcs



M5 hexagon wrench x 1pcs



M6 hexagon wrench x 1pcs

2. Product Overview

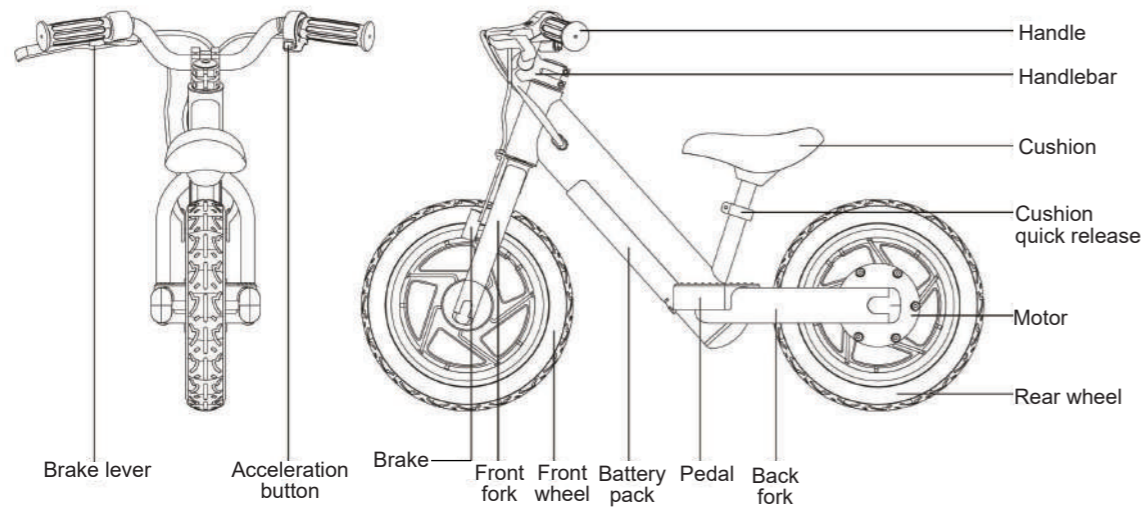

2

3. Assembly and Adjust Height

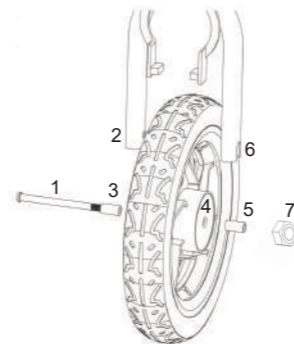

1. Use a screw to pass through the front fork, spacer, wheel and spacer, front fork, screw nut in turn, then tight the screw nut.

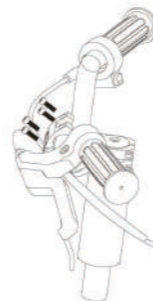

3. Adjust the handle to a suitable position and angle, and then tight the stem and the handle with four screws.

3

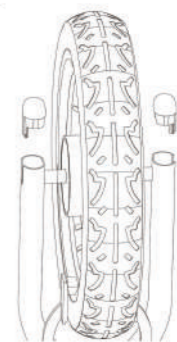

2. Knock the tube plug into the front fork with a rubber hammer.

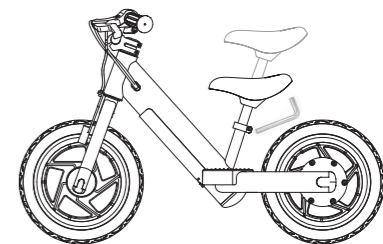

4. Adjust height: Open the screw of cushion quick release, adjust height of the cushion until it suits the height of the rider. Then, tight the quick-release screw.

4. Debug Brake



1. Loosen the nut with an open-end wrench.

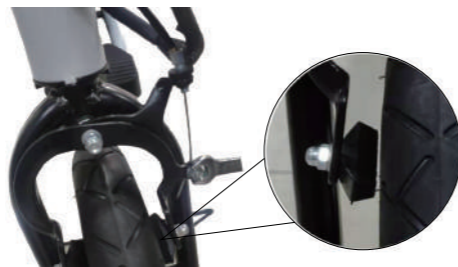

2. Pull the brake cable to a suitable position, center the two sides of the brake pads and keep 4-8cm gap between brake and wheel. Then lock the screw nut.



3. After debug Brake as shown in the figure.

5. Charging

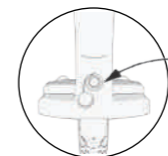
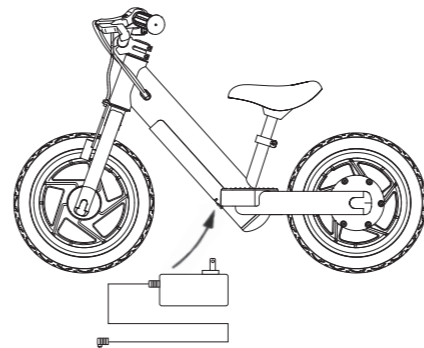

Open the rubber plug

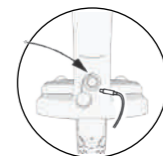

Insert the charging plug in

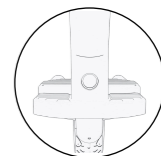

Fill and fix the rubber plug after the charging

Note:

- Your Kids Electric Bike will be fully charged when the LED light on the charger changes from red (charging) to green. When the battery is fully charged, please STOP CHARGING and unplug the unit.
- Do not charge when there is excessive odor/ heat, Leakage or physical damage.
- Do not connect the charger if the charging port is wet. Keep your charging environment clean and dry at all times.
- If the charging port is damp or has any liquid on it, do not charge your E-Bike.
- In order for the battery to operate at maximum efficiency, avoid charging your E-Bike in extremely hot or extremely cold environments.
- Use only the battery and charging cable provided to you by HIBOY. If a replacement is needed, please contact HIBOY directly.

6. Riding Basics

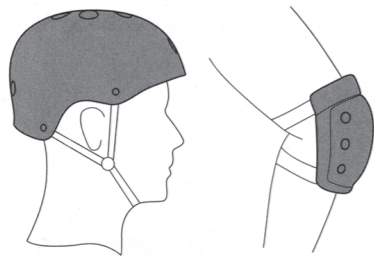

Always wear a helmet and safety gear so to avoid falling and injury during the driving learning, as shown in the figure.

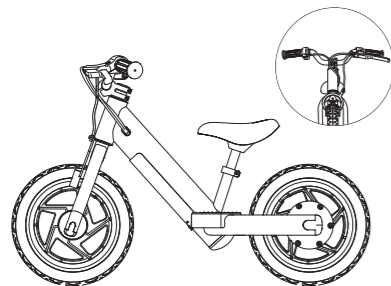

1. Hold both handles.



2. Gently kick off the ground to generate some speed by yourself.



3. When the E-bike begins to glide, press the accelerator continuously. Put both feet on the pedals as desired.

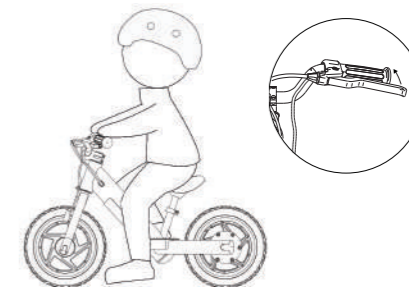

4. To slow down/stop, first right hand let go of the accelerator, then left hand gradually squeeze the brake to slow down/stop.

7. Riding Notice

Following these techniques and tips can ensure you have a safe, fun riding experience on the BK1 kids Electric Bike. Check to make sure your brakes are fully intact, pedals are securely installed, and handlebars are locked in place.

- Please use this kids E-bike with a guardian!! (3 years old riders should ride without power, 4-5 years old rider can ride with power or control in low speed, above 5 years old rider can ride with power and in high speed)
- Always wear an approved helmet and protective gear to avoid possible injury.
- Ensure your tires are intact with no punctures.
- Ensure the vehicle speed is safe to yourself and others, and be ready to stop at any time.
- When riding with friends, keep a safe distance between your devices to prevent collisions.
- Be aware of your surroundings at all times to ensure a safe ride. Your eyes are your best tools for safely avoiding obstacles and slippery surfaces.
- Stay in open spaces and flat areas, avoid steep slopes or high traffic areas.
- Only ride the kids E-bike where permitted, you must comply with local laws and give way to pedestrians.

8. Dangerous Actions (No Attempting!)

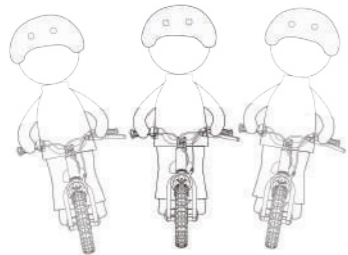

 Do not turn the handlebar violently during high-speed riding

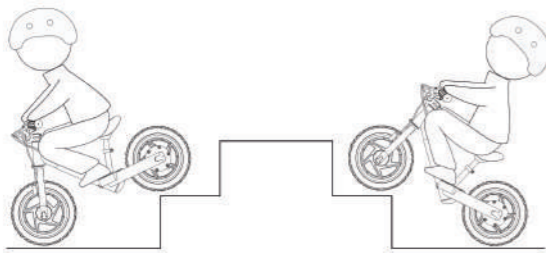

 Do not try riding up or down stairs, and jumping over obstacles



 Do not keep your hands away from handlebar.

9. Daily Care and Maintenance

Cleaning and storage

If you see stains on the kids E-bike 's body, wipe them off with a damp cloth. If the stains won't scrub off, put on some toothpaste, and brush them with a toothbrush, then wipe them off with a damp cloth.
Notes: do not clean the kids E-bike with alcohol, gasoline, kerosene or other corrosive and volatile chemical solvents to prevent dire damage. Do not wash the board with a high-pressure water spray. During cleaning, make sure that the kids E-bike turned off, the charging cable is unplugged, and the rubber flap is closed as water leakage may result in electric shock or other major problems. When the kids E-bike not in use, keep it indoors where it is dry and cool. Do not put it outdoors for a long time. Excessive sunlight, overheating and overcooling accelerate the battery pack's lifespan.

Battery maintenance

1. Use original battery packs, use of other models or brands may bring about safety issues;
2. Do not touch the contacts. Do not dismantle or puncture the casing. Keep the contacts away from metal objects to prevent short circuit which may result in battery damage or even injuries and deaths;
3. Use original power adapter to avoid potential damage or fire;
4. Mishandling of used batteries may do tremendous harm to the environment. To protect natural environment, please follow local regulations to properly dispose used batteries.
5. After every use, fully charge the battery to prolong its lifespan.

Storage and Disposal

1. Please try to store the kids E-bike in a cool and dry place between 14°F and 104°F. In extremely humid environments the interior of the scooter may suffer condensation or even water accumulation, which may damage the battery rapidly. Devices are not intended for use at elevations greater than 2000 m above sea level. Prolonged Exposure to UV Rays, Rain and the Elements May Damage the Enclosure Materials, Store Indoors When Not in Use.
2. In daily use, try to avoid recharging the scooter after completely exhausting the battery. If the battery is low, charge it as soon as possible.
3. Please charge the kids E-bike every other month to preserve the battery.

10. Specifications

BK1	Item	Electric Bike
Dimensions	Size	34.7*19.5*22.2 inch(880*495*565mm)
	Cushion height	15.7-18.1 inch (400mm-460mm)
Weight	Net Weight	17.64LB/8KG
	Max. Weight	77.16LB/35KG
User	Recommended Age	Above 3 years old
	Max. Speed	15 km/h
E-Bike	Max. Range	10km
	Max. Slope	5°
	Operating Temperature	0°C-40°C
	IP Rating	IPX4
Battery	Voltage	21.6V
	Max. Charging Voltage	25.2V
	Capacity	2Ah
Motor	Nominal Power	100W
	Input Voltage	100V -240V
Charger	Output Voltage	25.2V
	Output Current	0.5A
	Charging Time	3-5hours

11. Limited Warranty Statement

30 DAY SATISFACTION GUARANTEED RETURN POLICY

If you are unsatisfied with your purchase, Hiboy's return policy allows you to return the product purchased on the Authorization channel within 30 days counting from the date of receipt of shipment, and request a refund from the Authorization channel for any reason. Note: Express shipping cost is non-refundable.

For the return request, Hiboy is not responsible for lost packages due to the carrier, or products received that cannot be verified. Received products that have damage determined to have been caused by the end-user may be subject to denial of the return request.

TO QUALIFY FOR A REFUND, ALL THE FOLLOWING CONDITIONS MUST BE MET:

1. A Return Merchandise Authorization (RMA) must be requested from Hiboy within 30 days from the date of receipt of shipment. To request an RMA, contact Hiboy Service Team at us.support@hiboy.com.
2. The cost of return shipping will be borne by the customer.
3. For warranty service, please keep your receipt and/or invoice to validate proof of purchase.
4. Returned product must be in good physical condition (not physically broken or damaged).
5. All accessories originally included with your purchase must be included with your return.
6. If you return a product to Hiboy, (a) without an RMA from Hiboy(b) without all parts included in the original package, Hiboy retains the right to refuse delivery of such return.

LIMITED PRODUCT WARRANTY

Hiboy warrants the original purchaser that your Hiboy product shall be free from defects in materials and workmanship under normal use for a period aforementioned.

Hiboy does not warrant the operation of the product will be uninterrupted or error-free.

Hiboy is not responsible for damage arising from failure to follow instructions relating to the product's usage.

REMEDIES

If a hardware defect is found and a valid claim is received by Hiboy within the Warranty Period, Hiboy will, at its option and to the extent permitted by law, either (1) repair the product at no charge, using new or refurbished replacement parts or, (2) replace the product with a new or refurbished product. In the event of a defect, to the extent permitted by law, these are your sole and exclusive remedies. Shipping and handling charges may apply except where prohibited by applicable law. This Limited Warranty is valid only in the jurisdictions where the products are sold by www.hiboy.com, and is valid to the extent permitted by the applicable laws of such jurisdictions. Any replacement hardware product will be warranted for the remainder of the original warranty period or thirty (30) days, whichever is longer, or for any additional period of time that may be applicable in your jurisdiction.

HOW TO OBTAIN WARRANTY SERVICE

A Warranty Service Order must be requested from Hiboy within Warranty Period from the date of receipt of shipment. To request a Warranty Service Order, contact Hiboy Service Team us.support@hiboy.com.

To obtain warranty service, you must deliver the product, in either its original packaging or packaging providing an equal degree of protection, to the address specified by Hiboy. In accordance with applicable law, Hiboy may require the customer to furnish proof of purchase details and/or comply with registration requirements before receiving warranty service. period or thirty (30) days, whichever is longer, or for any additional period of time that may be applicable in your jurisdiction.

LIMITATION OF DAMAGES

Except to the extent prohibited by applicable law, Hiboy shall not be liable for any incidental, indirect, special, or consequential damages, including but not limited to loss of profits, revenue or data, resulting from any breach of express or implied warranty or condition, or under any other legal theory, even when Hiboy has been advised of the possibility of such damages. Some jurisdictions do not allow the exclusion or limitation of special, indirect, incidental or consequential damages, so the above limitation or exclusion may not apply to you.

Question & Answer

Q: What age and height of kids is it geared for?

A: The max load is 35KG. The age group is from 3 years to 9 years old .

Q: How long will this E- bike cost to fully charge?

A: It will need 3-5 hours to fully charge.

Q: How long would this bike last on the ride with fully charge?

A: The running time can be 30-50 mins

Q: What if the Kids E-Bike arrived missing accessory or broken part?

A: Please take a photo and send to Hiboy Support Team by sending email: us.support@hiboy.com
And Hiboy Support Team will reply you soon and send correct accessory or part replacement.

Q: Is that possible to replace some components for example the charger/battery?

A: Yes, please take a photo and send to Hiboy Support Team by sending email: us.support@hiboy.com
And Hiboy Support Team will reply you soon.

Q: Do you have video to show how to debug brake?

A: Yes, please visit www.hiboy.com to get detail video about install and debug brake.

Contact Us

Contact us if you experience issues relating to riding, maintenance and safety, or errors/faults with your Hiboy BK1

HIBOY INTELLIGENT INC

4050 Cheyenne Ct Chino CA 91710

E-mail Service: us.support@hiboy.com