

AIPEX®

ROBOTIC POOL CLEANER

User Manual

Orca 1200 Pro

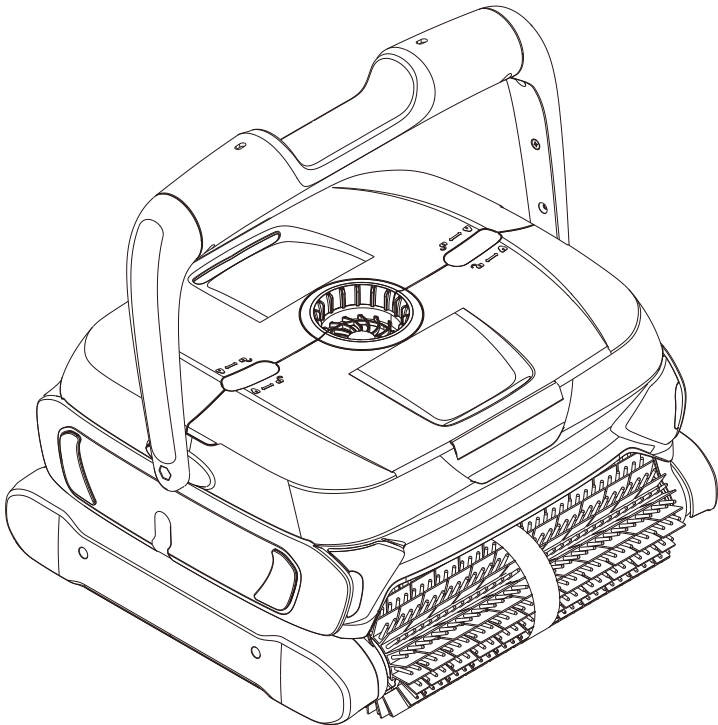

Thank you for choosing Aiper robotic pool cleaner.

You have joined millions of people to enjoy the convenience of robotic pool cleaning.

This user manual helps you to keep your robot performing at its best. Please take a few moments to read through it.

If you have any questions, please contact our customer service for assistance or visit www.aiper.com for more information.

Aiper Customer Service

Customer Service Number:

US Toll Free: 1-866-850-0666

Email: service@aiper.com

Facebook: [@AiperOfficial](https://www.facebook.com/AiperOfficial)

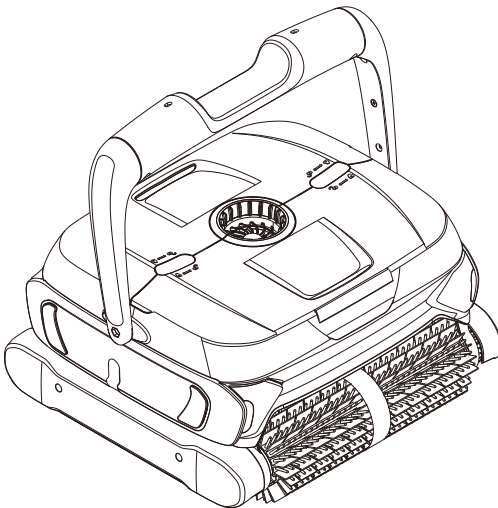

CONTENTS

Important Precautions -----	1
1. Introduction -----	2
2. Structure -----	2
3. Specifications -----	3
4. Operations -----	3
Attentions -----	3
4.1 Control Panel and Indicator Instructions -----	5
4.2 Filter Cleaning -----	6
4.3 Installation of Foam Floating Blocks -----	7
5. Trouble Shooting -----	8
6. Packing List -----	10
7. Warranty -----	10

Important Precautions

1. Read the manual carefully, and use the cleaner according to the manual. We are not liable for any losses or injuries caused by improper use.
2. To avoid any accidents/damages, it is strongly recommended to fix the power supply unit 11.5ft (3.5m) away from the swimming pool by using the included safety rope.
3. To prevent severe damages to the cleaner, never power on the unit when it is outside of the swimming pool.
4. The power cord must be connected to an appropriate earthed socket and the power connector must be plugged in tightly.
5. Hold the top handle when putting the cleaner into water or lifting out of the water, do not pull the cable. Before powering on, make sure to empty the trapped air inside the cleaner (no more air bubbles come from the cleaner and the cleaner is fully submersed on the pool floor).
6. Before powering on, make sure the filter baskets are assembled in position and the cord is fully released to avoid any winding, which could affect the cleaner's performance or cause damages.
7. Please clean and wash the filter baskets every time after use.
8. The cleaner should be stored in a cool and ventilated place, away from direct sunlight when it's not in use.
9. The power supply unit should be placed at a shaded area during working. To avoid overheating and potential damages of components, never cover the power supply unit during working.
10. Only authorized after-sales service personnels can open the cleaner's power supply unit and motor assembly, otherwise the warranty will be invalidated.
11. Do not use the cleaner beyond the working environment/conditions stated in this manual.
12. Make sure the PH value of the pool water is between 7.0~7.4.
13. This machine is to clean the pool only not for other purposes.
14. Do not use the cleaner immediately after spraying the pool chemicals and do not use the cleaner as a dosing machine, which will damage and corrode the belts.

15. Do not operate the cleaner when there are people or animals in the pool.
16. Take the cleaner out of the swimming pool after use. If the cleaner is immersed in the water for a long time, there will be micro organisms produced.
17. The cord should be untwisted and wrapped properly after use.
18. Use the original adapter only for the control box kit.
19. Do not operate the cleaner while pool filter is running.
20. Do not allow children to ride on the cleaner or play with it.

1. Introduction

The robotic pool cleaner Orca 1200 Pro is a new type of highly efficient and energy-saving swimming pool cleaning robot. Through its advanced computer-controlled program, it can clean the pool walls and floor automatically. With triple motors, it can automatically swerve for wider cleaning coverage. At the same time, it filters the pool water and gets rid of suspended particles without replacing the pool water. It's totally environmental-friendly.

Read the user manual carefully before use.

2. Structure

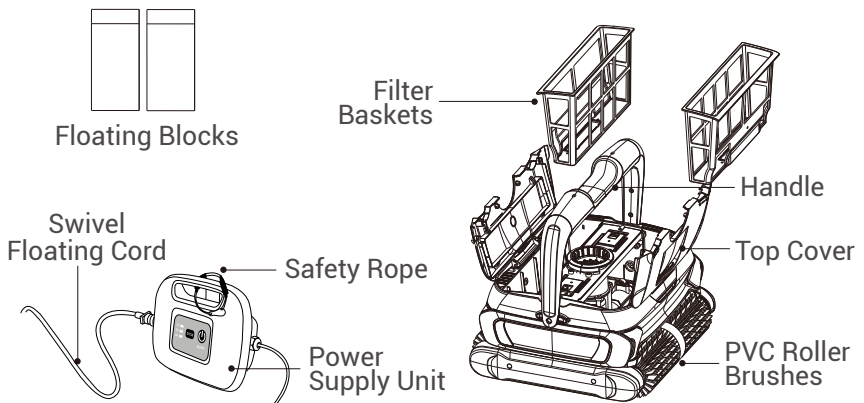

3. Specifications

1. Model	Orca 1200 Pro
2. Rated Input Voltage	110V~120V, 60Hz
3. Rated Working Voltage	DC 28V
4. Power	150W
5. Optional Working Cycles	1H/2H/3H
6. Pool Size	Up to 50ft (15m)
7. Filter Capacity	71GPM(267LPM)
8. Filter Density	180µm
9. Moving Speed	32.8ft/min (10m/min)
10. Waterproof Grade	IPX8 for the cleaner; IPX5 for the power supply unit
11. Pool Water Temperature	50°F~95°F (10 ~35)
12. Pool Water PH Value	7.0~7.4
13. Max Water Depth	8.2ft (2.5m)
14. Product Size	16.93(L)x15.35(W)x8.66(H) inches 430(L)x390(W)x220(H) mm
15. Storage Temperature	-4°F~113°F (-20 ~45), RH≤75%

4. Operations

Attentions:

1. When putting the cleaner into the water, please hold the top handle and make sure to empty the trapped air inside. Now, the cleaner can be immersed to the pool floor.

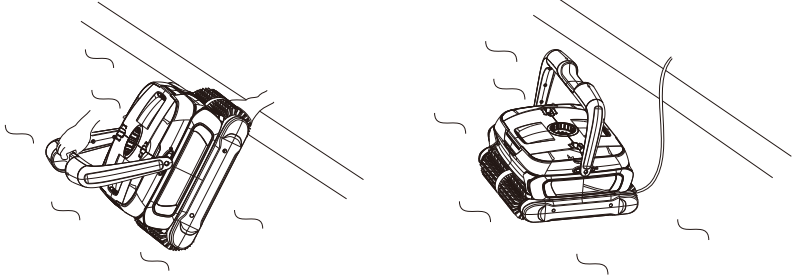

2. When pulling the cleaner out of the water, suspend the cleaner on the water for about 10-15 seconds to empty the water inside. Please hold the top handle only; never pull the cable.

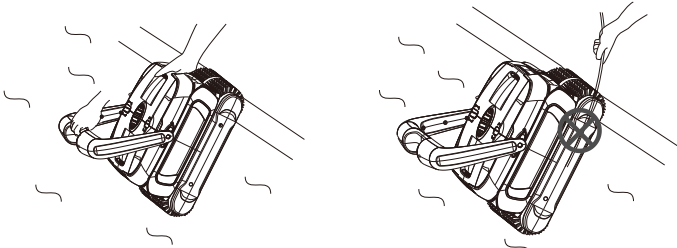

3. The power supply unit has to be placed in a proper position to reach the distal end of the pool, at least 11.5ft (3.5m) away from the pool edge.

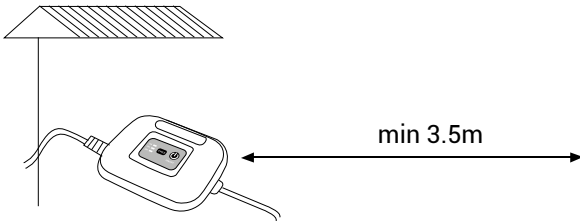

4. Please use the included safety rope to fix the power supply unit in case it drops into the pool.

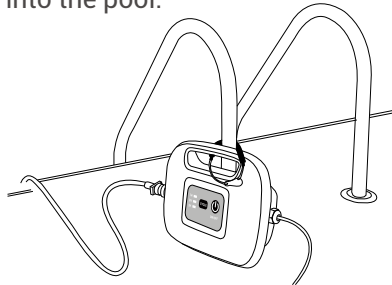

4.1 Control Panel and Indicator Instructions

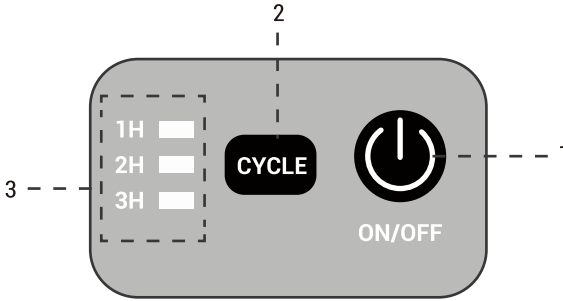

No.	Sign	Instruction	Function description	
1	ON/OFF	Power on/off	Press this button, the cleaner is power-on.	
			Press a second time, the cleaner is off.	
2	CYCLE	1H	The cleaner runs for 1 hour	
		2H	The cleaner runs for 2 hours	
		3H	The cleaner runs for 3 hours	
3	Indicator	Indicates the working cycle and fault warning		
		Working status	1H, 2H and 3H flash together	Working cycle completed
			"1H" flashes slowly	Cleaner running for 1 hour
			"2H" flashes slowly	Cleaner running for 2 hours
			"3H" flashes slowly	Cleaner running for 3 hours

			Status	Cause	Suggestion
3	Indicator	Abnormal Indication	1H and 3H flash together with a warning sound	Power Supply Overloading	Stop the cleaner and check if anything is blocked in the impeller or in the transmission system

4.2 Filter Cleaning

A. Slide the two clips according to the indications on the top cover to open it and take out the filters.

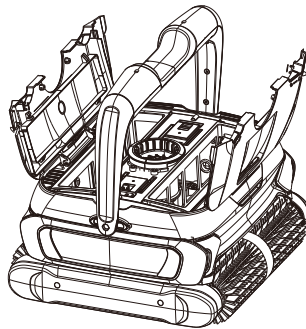
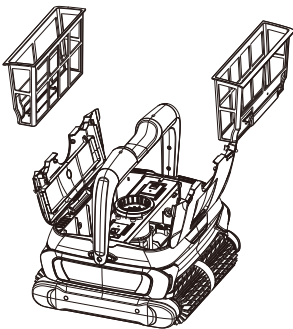
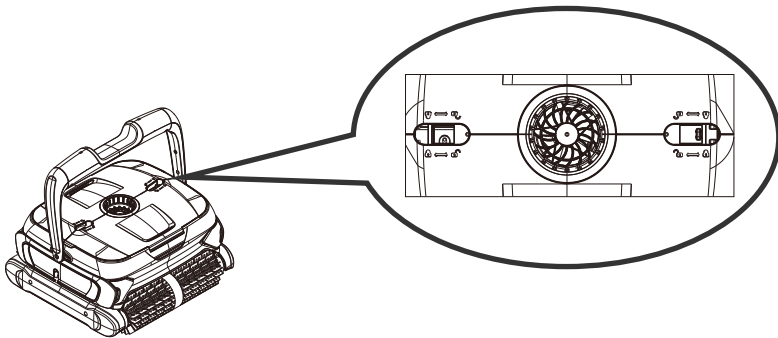

B. Clean and wash the filter baskets.

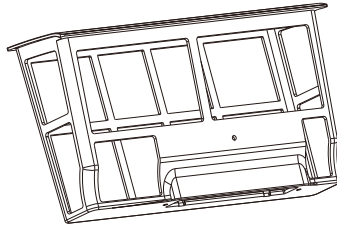

C. Re-install the filters, pay attention to the right position and slide the two clips to close the top cover.

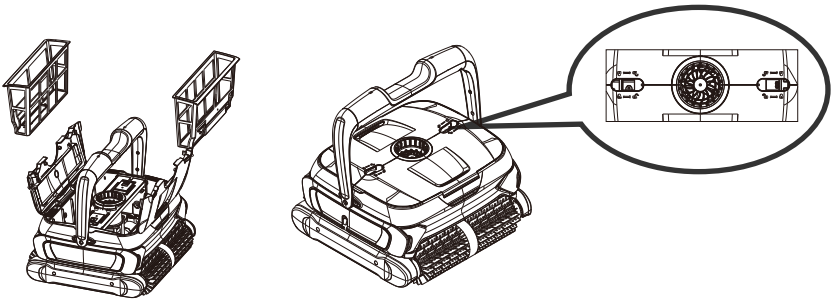

4.3 Installation of Foam Floating Blocks

Attention: If your robot is performing well, please ignore these instructions.

The following illustration is limited to the use of white foam blocks to increase coverage when the cleaning machine cannot completely clean and cover the pool area.

Stick the two foams on the internal surface of the top cover (see the picture below). Make sure the two foams are in the middle part of the top cover.

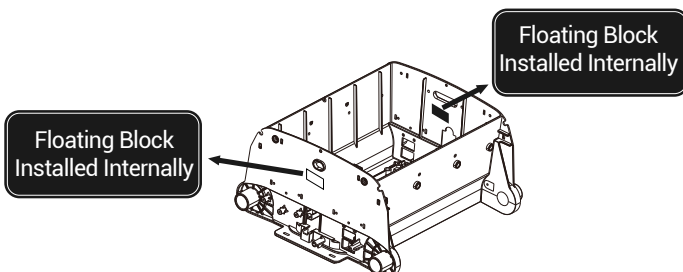

5. Trouble Shooting

Remark: The pool water condition must be within the following parameters:

- PH: 7.0 –7.4
- Salt: Max 5,000 ppm
- Temperature: 10°C(50°F) to 35°C(95°F)
- Chlorine: Max 2 ppm

Issues	Possible Causes	Solutions
The cable twists or coils up	The cable is not fully released	Unplug the power cord and fully release the cable
	Obstruction in the pool	Remove the obstruction
	Stuck on main drain outlet	Turn off the pool filter system
	Overtime working	Release the cable manually
The robot does not reach all pool areas	The power supply unit is improperly positioned	Place the power supply unit at a proper position to reach all pool areas
	There is algae on the pool floor and it can't be cleaned since it floats easily after the machine passes by	Before using the cleaner, please clean the algae on the floor or walls in case it floats when the machine passes by
	The pool shape is not regular	The ideal pool shapes are ROUND, OVAL, RECTANGULAR, KIDNEY-LIKE. Please place the robot on the area that needs specific cleaning

The robot does not reach all pool areas	The pool filter system and pump are running	Turn off the pool filter system and pump
	The cable is not long enough in the pool	Release the cable
The robot does not climb walls	The filter baskets need to be cleaned	Clean and wash the filter baskets
	The PVC rollers are worn or consumed too much	Replace new rollers
The robot does not work	The power cord is not plugged well	Plug the power cord tightly
	The robot is damaged during transportation	Contact the customer service
	The cleaner does not match the local rated voltage	Contact the customer service
	Electric Fault	Contact the customer service
	The cleaner gets blocked	Contact the customer service
It just sits at the bottom of the pool and won't move after several passes	<ol style="list-style-type: none"> 1. Check if the LED indicators on the power supply unit flash. If yes, it's probably because it has completed the scheduled 1H working cycle (default time); 2. There is a blockage in the filter baskets; 3. The belt is broken; If the belt is fine, there should be wrong with the motor, please contact the customer service. 	<ol style="list-style-type: none"> 1. Reset the cleaning time to 1H/2H/3H; 2. Clean up the filter baskets and restart the machine; Replace the belts. (Note: Please don't use the cleaner immediately after spraying pool chemicals, otherwise it will break belts easily)
It spends all its time in the deep area without visiting the shallow area	The pool shape is not regular like ROUND/OVAL/RECTANGULAR	Paste the included floating blocks on the shell surface (refer to 4.3 on the manual) to widen the cleaning coverage

6. Packing List

Item	Name	Quantity (PC)
Orca 1200 Pro	Cleaner with 50ft Cable	1
	Power Supply Unit	1
	User Manual	1
	Safety Rope	1
	Floating Blocks	2

7. Warranty

1. This product is covered by Aiper warranty for 24 months (only for driving kit and control box kit) from the date of purchase. Consumable parts are beyond warranty including Belts/Filter baskets/Rollers/ Side covers.
2. This warranty is voided if the product has been altered, misused, or has been repaired by unauthorized personnels.
3. The warranty extends only to manufacturing defects and does not cover any damage resulting from mishandling of the product by the owner.
4. The order number or record must be presented for any claim or repair during the warranty period.



Aiper Customer Service:

US Toll Free: 1-866-850-0666

Email: service@aiper.com

Facebook: [@AiperOfficial](https://www.facebook.com/AiperOfficial)