

## Who We Are

- SimPure® is a purification brand based in the United States, focusing on engineering filtration and advanced purification technologies.
- SimPure® promotes the philosophy of a minimalist lifestyle, returning to nature with clean water and fresh air.
- SimPure® designs products to be both smart, easy to operate, and practical in appearance and functionality.

## Contact Us

If you require technical assistance, please contact our friendly professional support engineers, who will be pleased to assist you.

4530 B STREET NW #A,  
AUBURN WA 98001, USA

Customer Service: [service@simpurelife.com](mailto:service@simpurelife.com)

Toll-Free: 1-866-528-4572

Website: [www.simpurelife.com](http://www.simpurelife.com)



4530 B STREET NW #A,  
AUBURN WA 98001, USA

# T1 Series

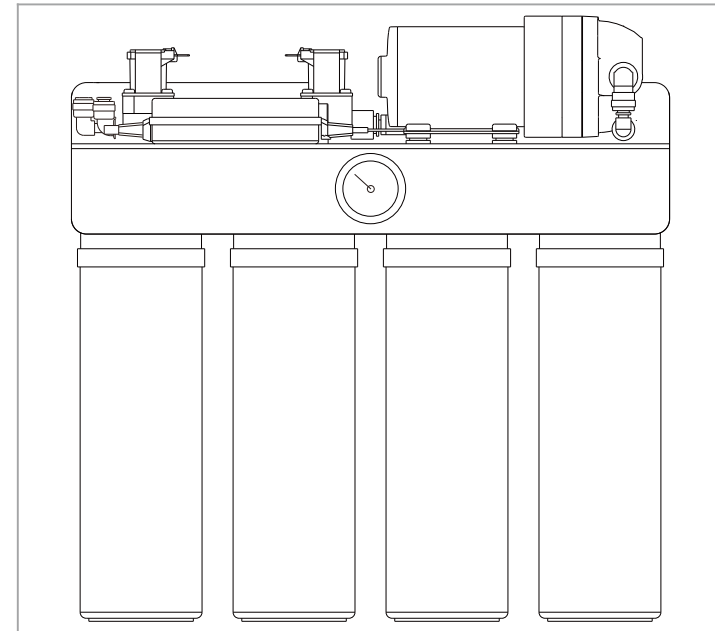

**RO Water Filtration System**  
**Model: T1-400UV**  
**T1-400ALK**

**Retain owner's manual for future reference**

# Table of Contents

Overview.....	<b>1</b>
Getting Started.....	<b>2</b>
Introduction.....	<b>2</b>
Warning and Caution.....	<b>3</b>
Operating Guidelines.....	<b>4</b>
Typical Installation.....	<b>5</b>
Installation(optional).....	<b>6</b>
Installation.....	<b>7</b>
System Contents.....	<b>7</b>
Installation Kit.....	<b>8</b>
Installation Guide.....	<b>10</b>
Installation Steps.....	<b>11</b>
Assemble the Components.....	<b>18</b>
Operation and Maintenance.....	<b>19</b>
Filter Cartridge Replacement .....	<b>20</b>
Frequently Asked Questions.....	<b>21</b>
Warranty.....	<b>23</b>
Our Products and Services.....	<b>24</b>

Operators and Maintenance Handbook.

SimPure® T1 Series RO Water Filtration System

Revision	Date	Description
01	03/2022	New document.
02	06/2023	Added T1-400ALK manual.

Images used in this manual may not represent your actual product; they are a visual aid only.

# Overview

## Getting Started



- Introduction
- Warning & Caution
- Operating Guidelines
- Typical Installation

## Installation Guide

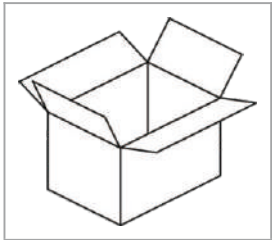

- Installation Kit
- Installation Guide
- Installation Steps
- Assemble Components

## Operation Guide



- Operation & Maintenance Guide
- Replacement Filter
- Frequently asked questions
- Warranty

# Getting Started

## Introduction

Thank you for purchasing the SimPure® T1-400 RO Water Filtration System which delivering purified water to your home or office. Please refer to the SimPure® website for the latest product information, including manuals, product videos, support materials, and where to purchase SimPure® products and consumables.

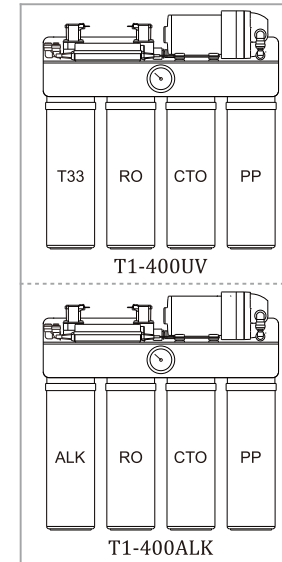

The T1-400 is a piece of durable equipment, with proper care it will last for many years. This owner's handbook outlines the installation, operation, and maintenance requirements to sustain better product performance.

The T1-400 features different stage of filtration to produce clean water for your family

- Sediment removal
- Chlorine removal
- Taste & odor filtration
- Reverse Osmosis (RO)
- T33(Composite activated carbon, Only for T1-400UV)
- ALK(pH and Alkaline adjustment, Only for T1-400ALK)
- UV

---

Customer Service: [service@simpurelife.com](mailto:service@simpurelife.com)

Toll-Free: 1-866-528-4572

Website: [www.simpurelife.com](http://www.simpurelife.com)

---

T1-400 can filter out impurities and particles from your water, such as sediment, dirt, rust, chlorine, odors, lead, organic matter, and heavy metals, offering a better water quality.

## Warning & Caution

SimPure® products are designed with safety in mind. However, personnel working on these units must be familiar with any potential dangers. All safety information detailed in this handbook should be reviewed before installing and operating this water purification system.

*Thoroughly flushing of the unit is required at start-up and when filters replaced (flushing instructions on page 16 of manual). The purpose of flushing is to remove protective liquid (Food-Grade Glycerin) in RO membrane and possible shipping dust.*

*This product is not a toy, please keep children away from the System or use under adult supervision. Please keep packing materials out of children's reach.*

*The System has been designed for indoor use only. Install the System out of direct sunlight and secure it to a vertical surface such as a wall or inside a cupboard at ambient room temperature.*

*Do not move the System without first shutting off the water supply, draining, and releasing the water pressure.*

*This unit is for use with cold municipal tap water or potable well water that has been tested safe by a certified laboratory. Never use hot water or unknown/unsafe sources of water.*

*The installation of the System must comply with your local and state regulations. Please check before commencing installation.*

*In case of malfunction, shut-off the water supply to the System. If any part of the System is damaged or missing, replace the item before use.*

**Warnings and Cautions are provided; Failing to observe the instructions could result in damage to the equipment, associated parts, surroundings, or personal injury.**

## Operating Guidelines

The following table lists the operating parameters for this product. Operating this product outside these specifications may cause system performance issues and may even lead to personal injury and void any warranty. Please contact SimPure® for further advice and support if unsure about the requirements.

Operating Parameters	
<b>Model</b>	SimPure® T1-400UV & T1-400ALK
<b>Difference</b>	T1-400UV, the fourth stage filter is T33 Filter, post carbon filter.
	T1-400ALK, the fourth stage filter is ALK Filter, pH and ALK adjustment filter.
<b>Maximum Flow Rate</b>	400 Gallons per day <b>Note:</b> Dependent on feedwater type, operating pressure and water temperature.
<b>Power Requirements</b>	110 Volts 60Hz AC. 62Watts
<b>Feed Water Type</b>	Municipal potable/tap water or well water meeting government drinking water standards
<b>Feed Water Pressure</b>	15 - 60 PSI <b>Note:</b> Install a pressure regulator if exceeding this feed water pressure
<b>Feed Water Temperature</b>	41-100°F (5-38°C)
<b>Ambient Temperature</b>	40-104°F (4-40°C)
<b>Feedwater TDS* level</b>	≤ 500 ppm
<b>UV Light</b>	UV wavelength range: 270~280nm UV dose: 8600uJ/cm <sup>2</sup>
<b>Water Hardness (Optional)</b>	For optimal results, use feedwater with a hardness level below 10 grains per gallon and no iron present.

\* TDS = Total Dissolved Solids, which is the total weight of all solids dissolved in a given volume of water, expressed in units of mg per unit volume of water (mg/L), also referred to as parts-per-million (ppm). With a SimPure® TDS meter, you can easily compare the system outlet quality with your source water to help monitor the performance of the system

## Typical Installation

The following illustration is an example of a typical under sink installation. No additional accessories required.

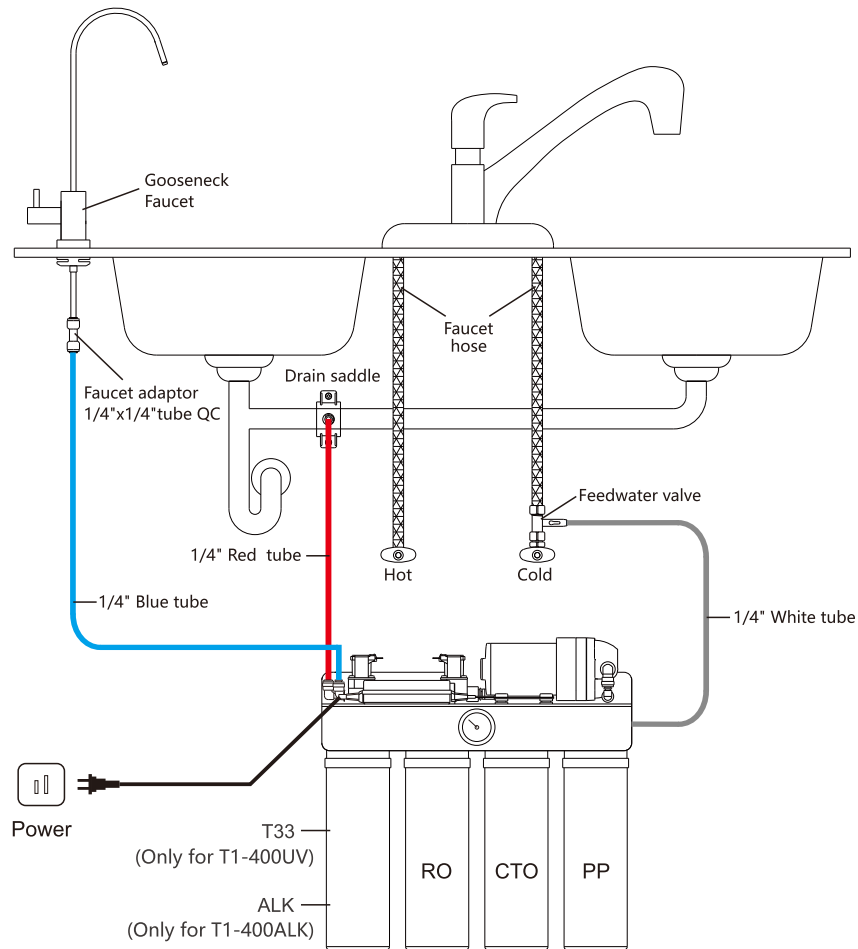

## Installation (optional)

The following instruction is how to connect to fridge. The pressure tank and accessories are required.

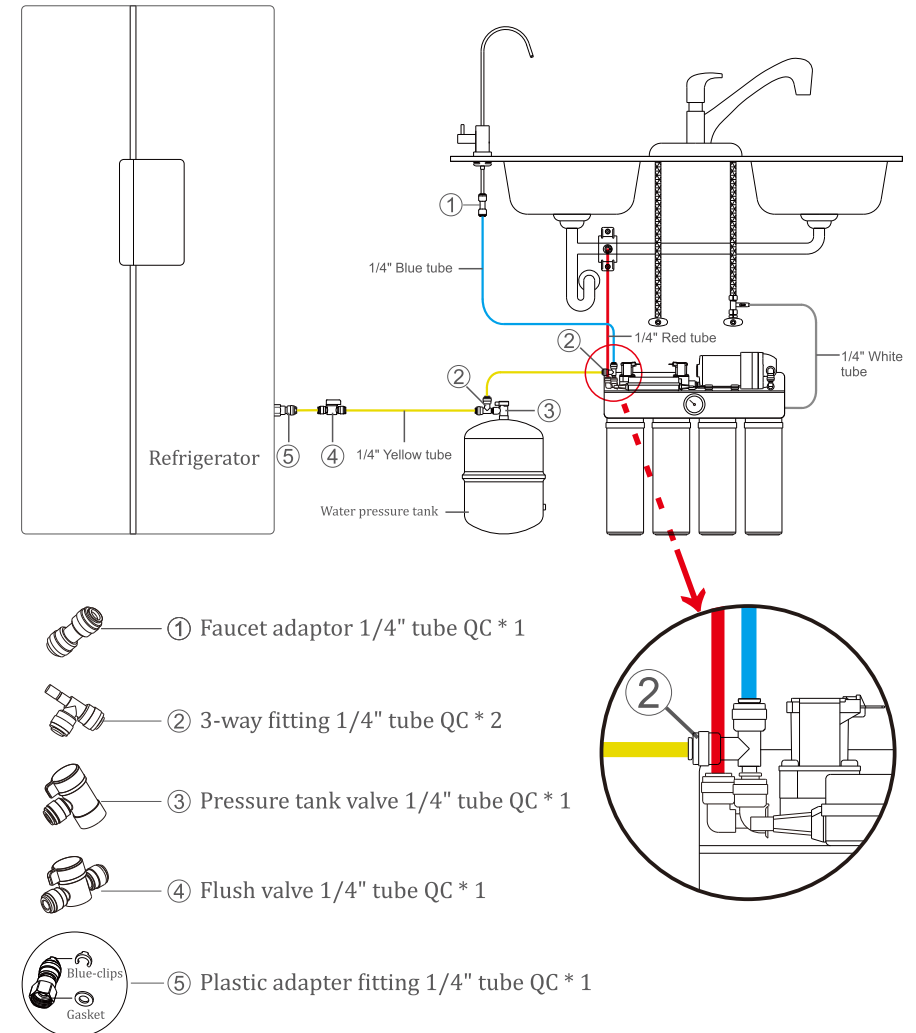

### Note:

The pressure tank and connectors are not included in the package. You need to purchase it separately.

# Installation

## System Contents

Your SimPure® T1-400 Water Filtration System was carefully assembled, packaged, and shipped complete with the parts required for a standard installation.

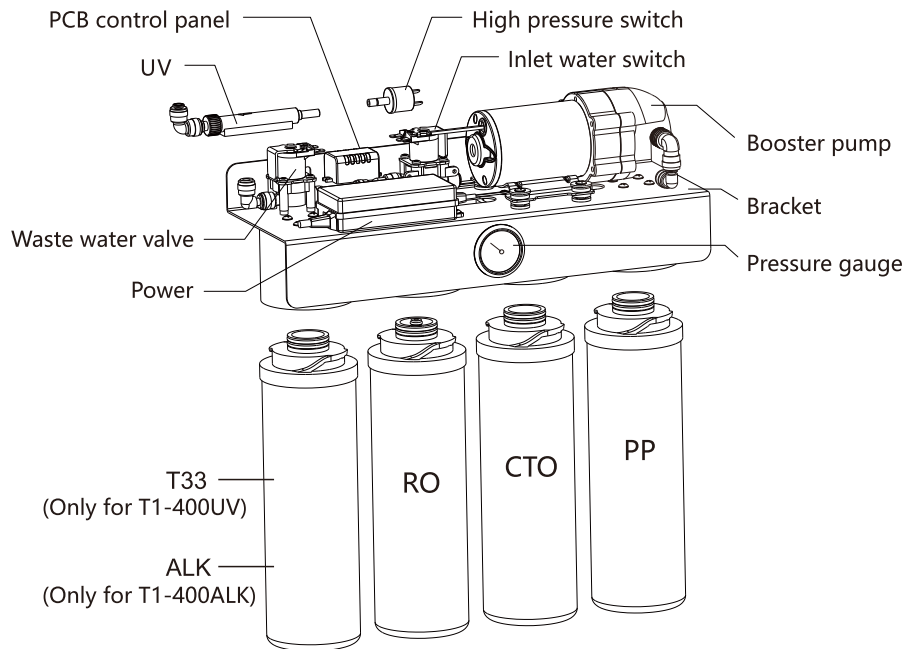

Uncertain about something? Is there a problem?  
Please contact SimPure® through our website or toll-free number.

Customer Service: [service@simpurelife.com](mailto:service@simpurelife.com)

Toll-Free: 1-866-528-4572

Website: [www.simpurelife.com](http://www.simpurelife.com)

## Installation Kit

Carefully unpack your SimPure® T1-400 Water Filtration System. Layout the parts, so you can familiarize yourself with the components, check nothing is missing before you start the installation.

Package Contents List	
	Description
A	Main body
B	PP filter cartridge
C	CTO filter cartridge
D	RO filter cartridge
E	T33 filter cartridge(Only for T1-400UV)
	ALK filter cartridge(Only for T1-400ALK)
F	Tubing ¼" PE (White, 59 inches)
G	Tubing ¼" PE (Blue, 59 inches)
H	Tubing ¼" PE (Red, 59 inches)
I	Gooseneck faucet
J	Faucet adaptor ¼" tube QC
K	Drain saddle
L	Feedwater valve 9/16"
M	Spare parts kit
M1	3/8" male comp. x 1/2" female NPT convertor fitting
M2	1/2" male NPT x 3/8" female comp. convertor fitting
M3	Teflon tape (roll)
M4	Faucet mounting plate
M5	Self-tap screws M5X36mm & wall plugs (x5)
M6	O-rings for filter cartridges (x4)
M7	Check valve, the arrow direction is the water direction

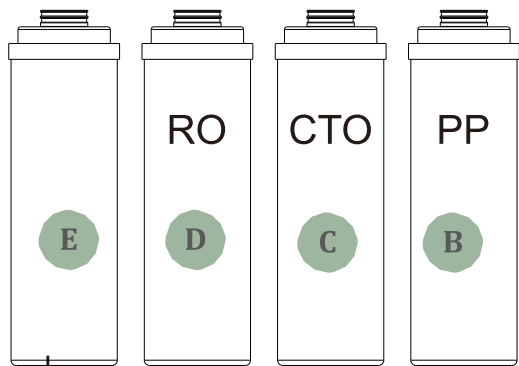
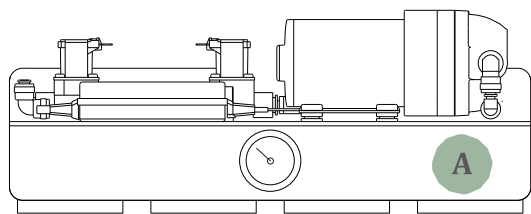

T33 (Only for T1-400UV)  
 ALK (Only for T1-400ALK)

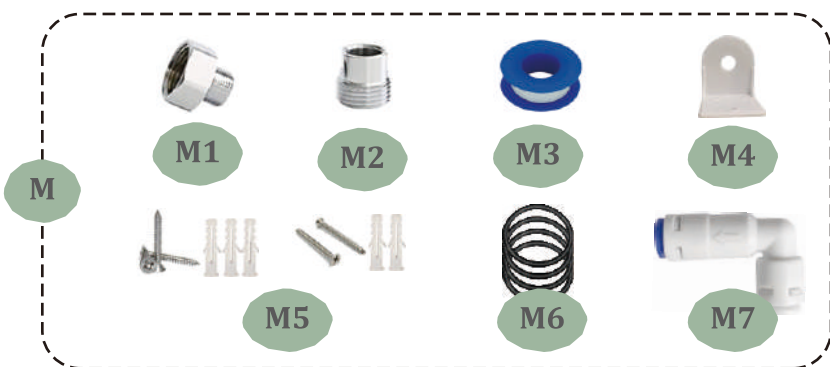

## Installation Guide

Read the entire manual thoroughly before beginning the installation. Take note of the safety tips and follow all steps to ensure your system is installed correctly before use. Installation needs to comply with state and local laws and regulations; It is required to check and comply with all local plumbing codes. Warning: Massachusetts, requires installation by a licensed plumber and does not permit the use of saddle valves. (plumbing code 248-CMR of the Commonwealth of Massachusetts)

### Hand tools required

Essential hand tools are required to install the SimPure® T1-400 RO water purification system. An electric drill, drill bits up to 1/2" (12.5mm), Adjustable wrench, tube cutters (or knife), cross-head screwdriver (Phillips).



### Plan your Installation

Your SimPure® T1-400 Water Purifier can be installed under a sink or in a remote location. Typical remote sites include a laundry room or utility room. Review the location options below and determine where you are going to install your system.

- **Option 1: Under-Sink.** The unit can be installed in a kitchen or bathroom sink cabinet. A suitable drainpoint is required to drain water from the Reverse Osmosis system.  
**If you intend to wall-mount it, the spare kit accessories include a positioning label for wall-mounted holes.**
- **Option 2: Remote Location.** The unit may also be installed in a remote location away from the RO Faucet. A nearby feed water source and drain point connection are necessary, and you may need additional tubing or a delivery pump depending on how far away you plan to install or if you plan to link to a refrigerator.

### Please Attention:

1. When the T1-400 RO system is connected to the refrigerator/ice maker at the same time, the water flow rate will slow down.

2. You may need to purchase additional pressure tank equipment and tubing to alleviate water flow problems.
3. It is recommended that contact our customer service before connecting the refrigerator/ice maker.

### Check Location and Space Requirements

Determine and check the size and position of the T1-400 for proper installation into the chosen space and remember to leave enough room around the System for changing filters and maintenance.

## Installation Steps

### Step 1 - Install the T1-400 Assembly

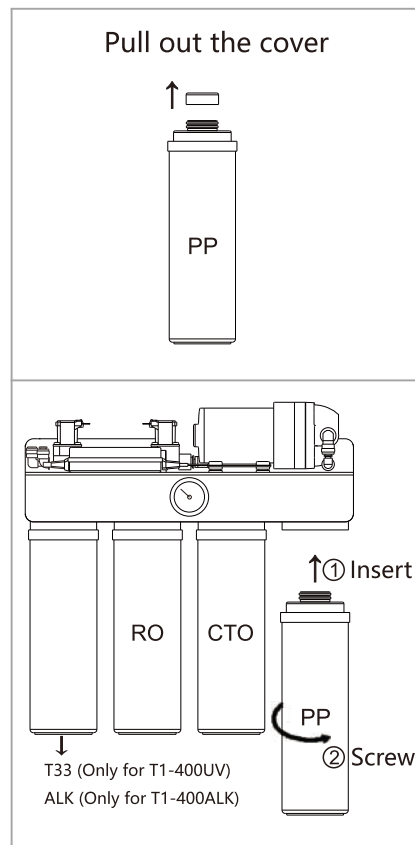

#### Take out the filter cartridges.

Remove the protective film and pull out the protective cover.

#### Install the filter cartridges.

According to the mark on the main body, insert the corresponding filter cartridge into the main body first, and then screw it tightly.

Install the PP, CTO, RO and T33 or ALK filter cartridges in sequence.

**Warning:** Refer to the markings to ensure that each filter cartridge is installed in the correct location.

### Step 2 - Install the feed water adaptor valve

If the cold water valve outlet is 3/8", it can be directly connected by following steps.

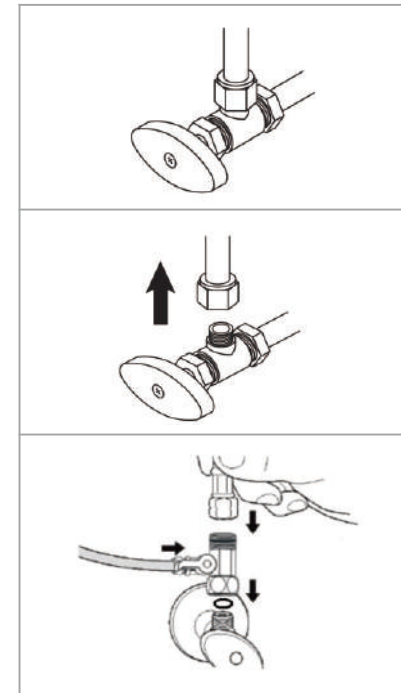

**Locate Shut off valve.** Turn off the COLD water shut off valve located under the sink.

**Warning:** Make sure you have turned the water supply off before starting any plumbing work.

**Remove the original connection** from between the faucet and the cold water shut off valve under the sink. Connect the cold-water supply and feed water adapter valve.

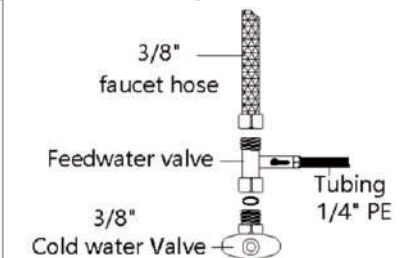

**Note:** Please check if the sealing ring is installed, or it may leakage.

If the cold water valve outlet is 1/2", it can be connected via the following two fittings.

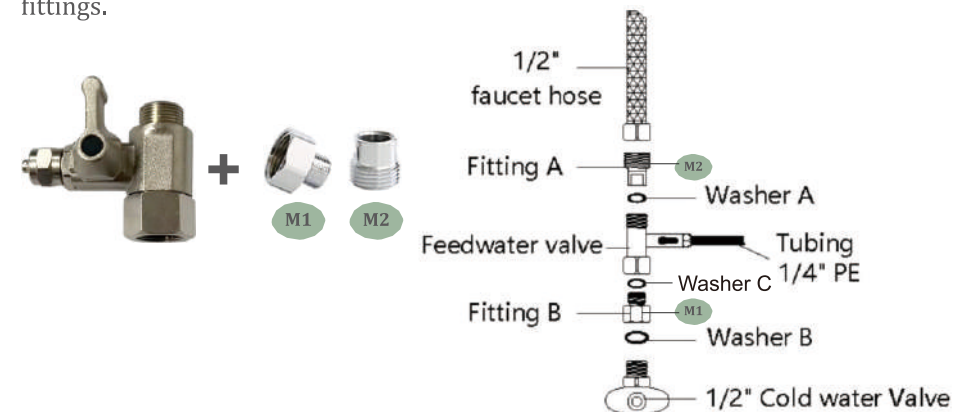



### Step 3 - Install the faucet

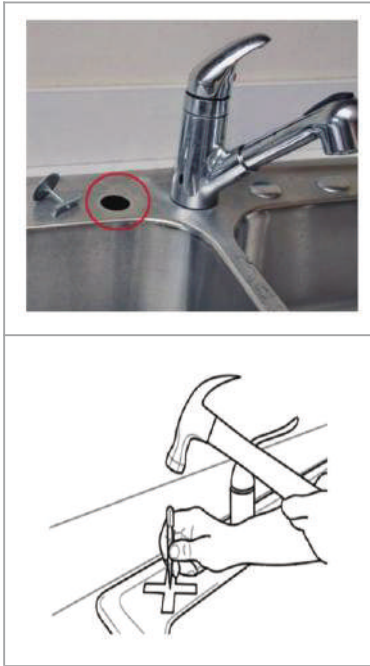

**Fixing to the Sink.** Try to install the faucet on the sink surround if possible, using one of the mounting holes already available, remove the cover, make sure you have clear access above and below.

If there are no additional holes available, you will need to drill a suitable hole. Max. thickness 1.2 inches. If you need to drill the countertop, especially for granite, tile, or concrete ones, you may need professional assistance.

Using a hammer and center punch, mark the hole. Drill a pilot hole first, working up to 1/2" (12.5mm) drill bit. Insert the faucet through the hole with the top gasket in place and secure it with the locknut.

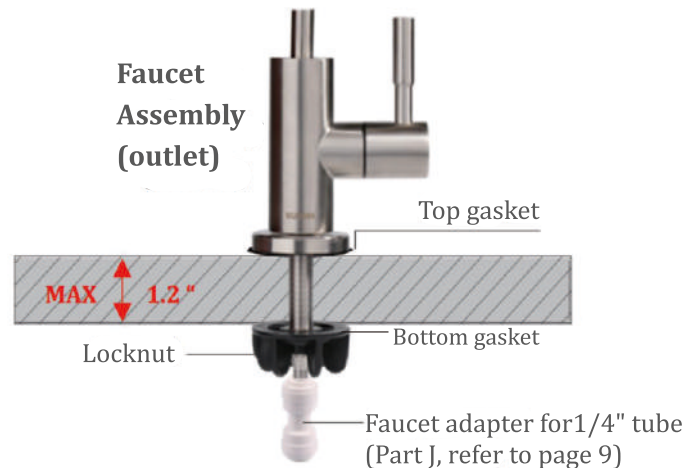

### Step 4 - Install the Drain Saddle

If installing the product under a sink, make sure you connect the drain to a straight piece of pipe and make sure it is BEFORE the water trap ('P' trap or 'U' bend) see diagram below.

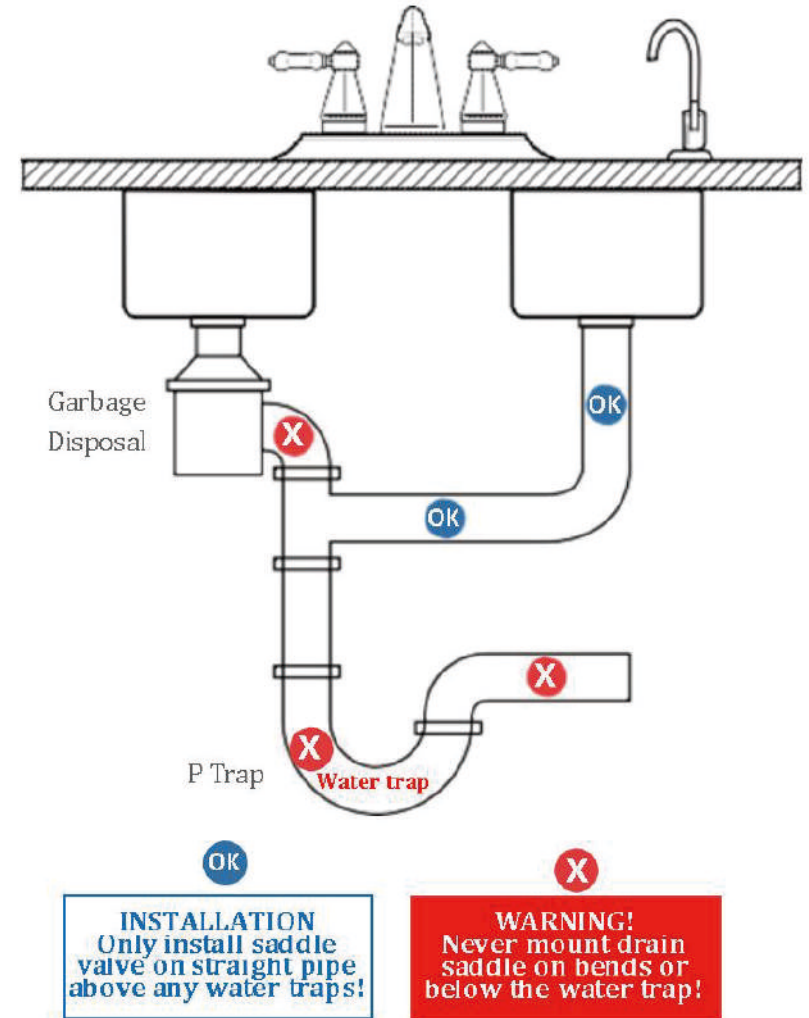



Drill a 1/4" (6.5mm) hole on the drainpipe with an electric drill.



Remove the backing and stick the saddle valve seal on the pipe, line up the holes.

Assemble the drain saddle valve according to the diagram below and tighten the bolts evenly with the cross-head screwdriver to allow the clamp to fit snugly around the pipe (Do Not Overtighten). Once secure, insert the 1/4" PE tube into the saddle valve QC fitting.

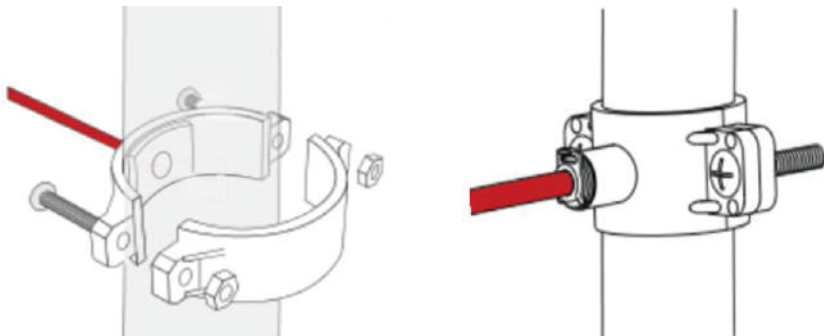

## Step 5 - Connect Tubing (refer to page 18 for instructions on use of Quick Connect Fittings)

Follow the instruction below to connect the SimPure® T1-400 Filtration System.

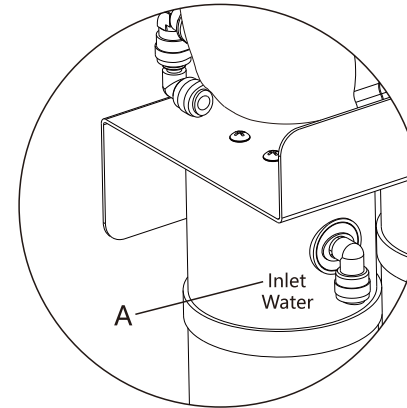

### 1. Inlet Water (A)

Use 1/4" **white tube** to connect the Inlet water port and the **Feedwater Valve**. (refer to white tube connect)

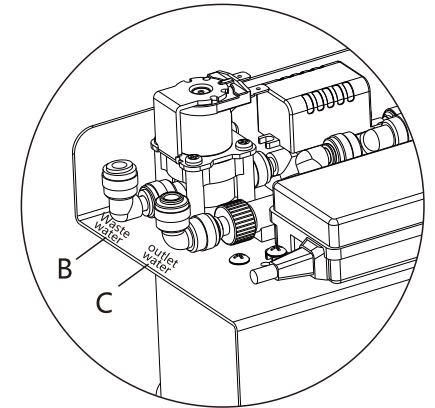

### 2. Waste Water (B)

Use 1/4" **red tube** to connect the waste water port and the **Drain Saddle**. (refer to red tube connect)

### 3. Outlet Water (C)

Use 1/4" **blue tube** to connect the outlet water port and the **Gooseneck Faucet**. (refer to blue tube connect)

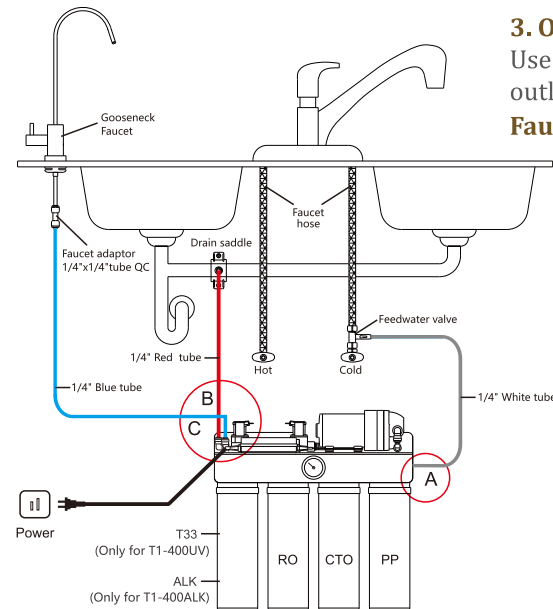

## Step 6 - System Flushing(start up the system and filter replacement)

**1.System flushing---**Turn on the Feedwater valve and gooseneck faucet, then plug in and let the system run for 20 minutes to rinse all fittings and the new filter. Check for any signs of leaks.

**Warning:** Make sure the socket under the sink is powered on, and ensure the system has been plugged correctly into the power outlet.

**Note:** You may notice Black Carbon particles for the first minute, this is normal.

**2.Enjoy your drinking water---**After flushing, the system is ready for use. Turn on the faucet and enjoy it.

**Note:** There will be some noise when the system is running, this is normal.

Uncertain about something? Is there a problem?  
Please contact SimPure® through our website or toll-free number.

Customer Service: [service@simpurelife.com](mailto:service@simpurelife.com)

Toll-Free: 1-866-528-4572

Website: [www.simpurelife.com](http://www.simpurelife.com)

**CONGRATULATIONS!**  
**You have completed the installation!**

## Assemble the Components

The SimPure® T1-400 System uses quick-connect (QC) fittings making the installation simple and easy.



### How to insert the tube into a quick-connect.

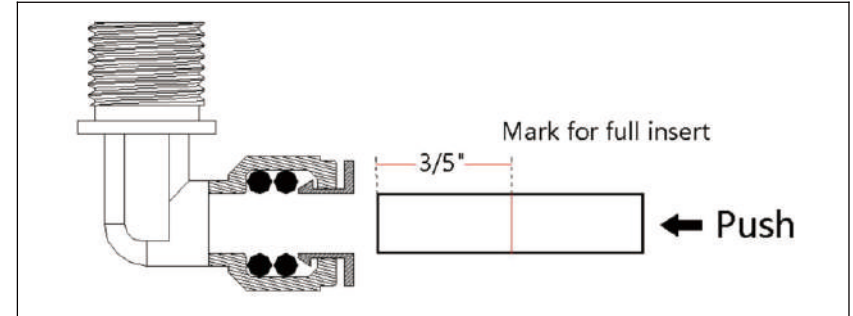

- (1) Make sure the tube has a clean square cut with no burr present.
- (2) Push the tube firmly into the QC fitting, making sure it is located correctly (you will feel the tube 'jump' into position as you push it into the fitting). The tube is secure once it has traveled  $\frac{3}{5}$ " (15mm) into the fitting.

### How to release a tube from a quick-connect.

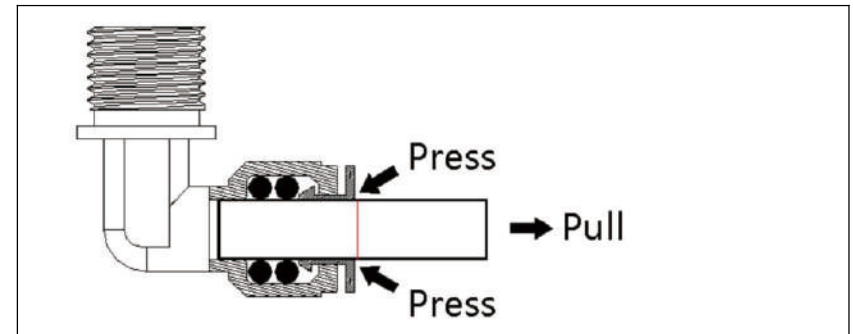

- (1) Push the collet down onto the fitting (closing the gap between the collet and fitting) and hold.
- (2) While holding the collet down, gently pull the tube in the opposite direction at the same time to release.

## Operation and Maintenance Guide

It is important to maintain the filters and RO membrane to ensure the outlet water quality is a consistently high standard.

The life expectancy of filters and replacement schedule is dependent on source water quality and water consumption.

Under normal situations, we recommend users replace filters as per the table below:

Replacement Filter Part Number		
Part No.	Description	Replacement Schedule (Months)
T1-400 PP	PP Filter Cartridge	3-6months
T1-400 CTO	CTO Filter Cartridge	3-6months
T1-400 RO	RO Filter Cartridge	12months
T1-400 T33	T33 Filter Cartridge	3-6months
T1-400 ALK	ALK Filter Cartridge	3-6months

### Note:

1. When the flow of pure water is less than 0.5L/min, the filter cartridges need to be replaced.

If the pressure gauge shows more than 130 PSI, the RO filter cartridge need to be replaced. Otherwise, you need to replace other filters.

2. Due to the difference in feed water quality, the above is an estimate only. Please contact SimPure® for purchase options.

Customer Service: [service@simpurelife.com](mailto:service@simpurelife.com)  
Toll-Free Phone: 1-866-528-4572

## Filter cartridge replacement steps

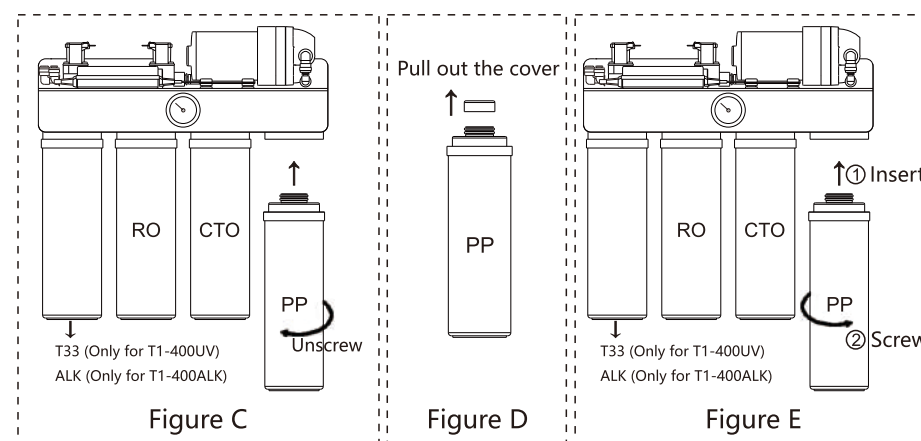

**Step 1** – Close the shut- off valve and turn on the faucet to release any water pressure.

**Step 2** – Unscrew the old filter cartridge.(See Figure C)

**Step 3** – Take out the new filter cartridge. Remove the protective film and pull out the protective cover.(See Figure D)

**Step 4** – Insert the new filter cartridge into the main body first, and then screw it tightly.(See Figure E)

**Note:** Refer to the markings to ensure that each filter cartridge is installed in the correct location.

**Step 5** – Run water to drain for 20 minutes to rinse the new cartridge.

**Note:** You may notice Black Carbon particles for the first minute, this is normal.

Customer Service: [service@simpurelife.com](mailto:service@simpurelife.com)

Toll-Free: 1-866-528-4572

Website: [www.simpurelife.com](http://www.simpurelife.com)

## Frequently Asked Questions

### **Q: The system cannot be powered on after you insert the power plug.**

**A1:** The power socket of the garbage disposal may not be applicable to this system,

**a.** Please try a different socket if there is no power.

**b.** There is problem with the power sockt, purchase air switch or wireless wall switch to repalce it.

**c.** Employee a professional plumber to reconnect the wiring for the under sink.

**A2:** Please help check if there is a loose wire connection.

### **Q: No output water from the faucet.**

**A1:** Water supply is off: Turn on the feed water adapter or water supply valve

**A2:** Incorrect filter installation: Reinstall the filter and make sure each filter cartridge is installed in the correct location.

**A3:** A tubing is crimped: Check all the tubing and remove any crimps.

**A4:** The connection between the inlet and outlet water tube is incorrect; Check if the inlet water tube is connected to the outlet of the system and the outlet tube is connected to the inlet of the system. If so, please install it correctly according to the manual.

**A5:** Please check if the faucet is connected to the elbow check valve by mistake, it should be connected to the the straight fitting (Part J, refer to page 9).

### **Q: Low water flow at the faucet.**

**A1:** A tubing is crimped or there is a leak from the tubing connection: Check to ensure that all tubing is installed correctly and completely.

**A2:** Low water temperature: Be sure to use it at a temperature of 41-100°F.

**A3:** Low water pressure: Confirm the water pressure is between 15-60 psi.

**A4:** The filter cartridge has been clogged: If you are using well water as the source, please ensure that the feed water has been through a pre-filtration system. Otherwise, large particles in the well water will easily clog the filter and shorten the filter life.

### **Q: Why does black water come out during flushing?**

**A:** It's normal that black water comes out when flushing. The purpose is to remove carbon powder remaining on the surface of filter materials.

After flushing for 5 minutes, the water is ready to use.

### **Q: Filtered water from the faucet tastes like tap water.**

**A1:** Incorrect tubing installation: Make sure the drain tubing is not connected to the faucet.

**A2:** The filter is expired: Replace the T33 filter(for T1-400UV), ALK filter(for T1-400ALK) or RO filter cartridge.

### **Q: What should I do if the system is leaking.**

**A1:** Check all the joints, filttings, and tubing connections to locate the leakage. Make sure the cartridges are well installed. Turn off shut off valve, then solve it.

**A2:** Check whether the filters' O-ring is deformed, there has four O-rings in the spare part, please try to replaced.

### **Q: When the faucet was turned off, the wastewater is still flowing out.**

**A:** The solenoid valve is damaged. Please contact SimPure Customer Service for support.

### **Q: The taste of water is poor or has a strange odor.**

**A1:** Adsorption of the T33 filter(for T1-400UV) or ALK filter(for T1-400ALK) is saturated, please replace the T33 filter or ALK filter cartridge.

**A2:** The pipeline was incorrectly connected. Check if the pipeline is connected correctly according to the manual.

**A3:** The system has not been used for a long time. Replace all filter cartridges and flush the system.

### **Q: The system emits significant noise during operation.**

**A:** Inlet water quality is poor. The filters are blocked (before replacement schedule). Please replace the PP, CTO and RO filters. Check the quality of inlet water.

**Note:** The system will make some noise when filtering water which is normal.

## Warranty

SimPure® warrants to the customer that its residential Filtration System will be free from defects in material and workmanship under normal use and service for a period of 1 year. We will replace or repair any part of the SimPure® T1-400 System that we find to be defective in operation due to faulty materials or workmanship within one year since the date of the original purchase. Used replaceable filter cartridges and membranes are excluded.

### General Conditions

SimPure® obligation to the customer under these warranties shall be limited, at its option, to replacement or repair of items covered by these warranties. Prior to return or repair of covered items, the customer must obtain a return goods authorization number from SimPure® and, at SimPure® option, return the item with freight prepaid by the customer.

Damage to any part of this System because of misuse, misapplication, negligence, alteration, accident, installation, or operation contrary to our instructions, incompatibility with accessories not installed by SimPure®, or damage caused by freezing, flood, fire, or Acts of God are not covered by this warranty. In all such cases, regular charges will apply. This limited warranty does not include service to diagnose a claimed malfunction in this unit. This warranty is void if the claimer is not the original purchaser of the unit or if the unit is not operated under normal municipal water or well water conditions. We assume no warranty liability in connection with this System other than that specified herein. This warranty is in lieu of all other warranties, expressed or implied, including warranties of fitness for a particular purpose. SimPure® liability hereunder shall not exceed the cost of the product. Under no circumstances will SimPure® be liable for any incidental or consequential damages or for any other loss, damage or expense of any kind, including loss of use, arising in connection with the installation or use or inability to use the covered items. These warranties are governed by the laws of the state of Washington, USA, and may change at any time without notice.

# Our Products & Services

## Consumables

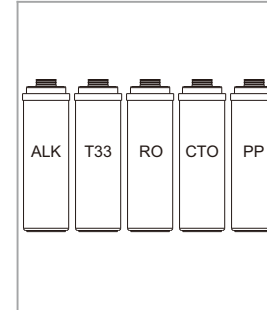

Full selection of consumable items to maintain your SimPure® T1-400 System well into the future are available from SimPure® online or through your local Distributor.

## Whole House Filtration System



SimPure® Whole House Pre-Filter (DC5 series and Big blue series ) help to purify the water coming into your home.

Lasts Longer To Give You The Best Value In Filtration.

## Reverse Osmosis System



SimPure® Y7P Countertop RO Water Filtration System help to improve your life.

Eliminate the need to purchase bottled water for your home.