

Oxygen Concentrator User Manual

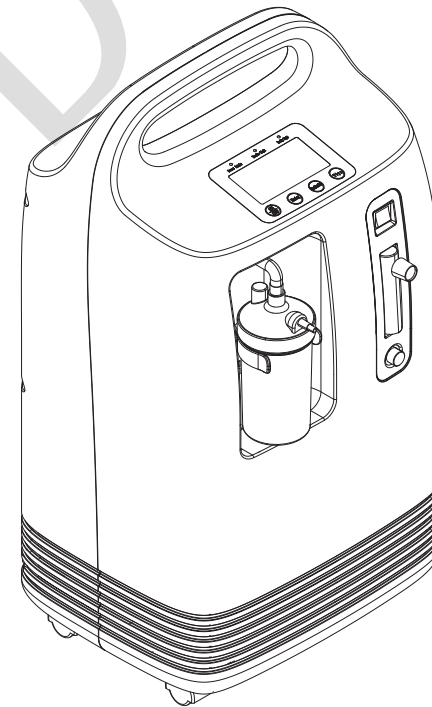

Please read the instruction carefully before use the machine

Issue Date: 2021.01.21, Ver.1.0

Table of Contents

1. Product Overview.....	01
2. Safety Overview.....	02
3. Structural Features.....	03
4. Technical Indicators.....	04
5. Product Installation.....	05
6. Product Use.....	06
7. Cleaning & Maintenance.....	11
8. Technical Parameter.....	13
9. Electromagnetic Environment Guidance.....	14
10. Transportation and Storage.....	18
11. Symbols and Meanings for Security Requirements.....	19
12. Troubleshooting Guide.....	20
13. Limited Warranty.....	21
14. Packing List.....	21

13. Limited Warranty

Manufacturer warrants that the system shall be free from defects of workmanship and materials and will perform in accordance with the product specifications for a period of 2 years from the date of manufacture or 5000 hours(which one is earlier). This warranty does not cover damage caused by accident, misuse, abuse, alteration, and other defects not related to material or workmanship.

Manufacturer disclaims all liability for economic loss, loss of profits, overhead, or consequential damages which may be claimed to arise from any sale or use of this product. Some states do not allow the exclusion or limitation of incidental or consequential damages, so the above limitation or exclusion may not apply to you.

14. Packing List

No.	Name	Unit	Qty	Remarks
1	Machine	Set	1	
2	Romote control	pc	1	Optional
3	Nasal cannula	pc	2	
4	Nebulizer	Set	1	Only atomization models
5	Connecting tube of humidifier bottle	pc	1	
6	Humidifier bottle	pc	1	
7	Air filter	pc	1	
8	Hepa filter	pc	1	
9	User manual	pc	1	
10	Warranty card	pc	1	

12. Troubleshooting Guide

Problem	Possible Cause	What to Do
A. The device is not working when it is turned on. (The Audible Alarm is sounding continuously. All LEDs are off)	The power cord plug is not properly inserted into the electrical outlet.	Make sure the device is properly plugged in to the electrical outlet.
	The unit is not receiving power from the electrical outlet.	Check your household outlet fuse or circuit.
	Internal part failure.	Connect to a back up oxygen source and contact your provider.
B. The device is not working when it is turned on. (The Audible Alarm is sounding continuously and the red light is illuminated)	Internal part failure.	Connect to a back up oxygen source and contact your provider.
C. Limited oxygen flow to the user without any fault indication (All LEDs and the Audible Alarm are normal)	The oxygen tubing or cannula is faulty.	Inspect and replace the items if necessary
	There is a poor connection to a device accessory.	Ensure that all connections are free from leaks.
D. Yellow LED or Red LED is illuminated and the Audible Alarm is beeping periodically (Only the model with oxygen concentration alarm function)	The device has detected a high oxygen flow condition.	Turn the flow rate down to your prescribed level. Wait at least 2mins, if the condition persists turn the unit off, connect a back up oxygen source, and call your provider.
E. If any other problems occur with your oxygen concentrator.		Connect to a back up oxygen source and contact your provider.

NOTE: Please contact the provider or manufacturer if there are any other malfunctions.

1. Product Overview

Welcome to choose the oxygen concentrator manufactured by our company!

Our oxygen concentrator adopts 220V/110V AC power supply, uses air as raw material and high-quality molecular sieve as adsorbent, and adopts the principle of pressure swing adsorption (PSA) to directly separate oxygen from nitrogen at normal temperature, oxygen of high purity is thereby produced.

In order to ensure the safety and effectiveness of oxygen concentrator, please read this manual carefully before using the machine, so as to have a comprehensive understanding and knowledge of the product performance as well as correct operation and maintenance methods. Please strictly observe relevant safety precautions during installation, use and maintenance.

1. Functions of oxygen

By supplying oxygen to patients, the machine can help the treatment of cardiovascular and cerebrovascular diseases, respiratory diseases, chronic obstructive pneumonia etc. and the rehabilitation of anoxic patients.

Oxygen absorption can improve physical oxygen supply condition and achieve the purpose of oxygenating care. It is suitable for the middle-aged and elderly, people with poor physical fitness, pregnant women, students and other people who suffer different degrees of physiological hypoxia. It can also eliminate fatigue and restore somatic function after heavy physical or mental exertion.

2. Scope of application

It is applicable for oxygen concentrator in medical institutions and family etc. for the use of anoxic patients.

3. Product features

1. Plastic casing, novel design, simple operation, stable operation, easy maintenance.
2. Generate oxygen adopting physical methods, with air as raw material, without the use of additives, only needing power supply, with low cost.
3. Adopt pressure swing adsorption (PSA) technology of efficient molecular sieve, with simple process flow and low energy consumption.

4. Specification & model

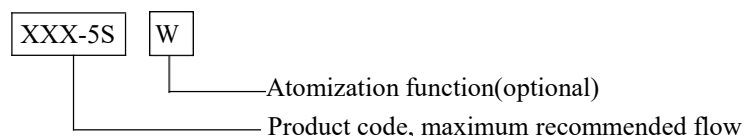

2. Safety Overview



1. This product can not be used for life support or life sustaining. Patients who can not express discomfort or can not hear or see alarm signals require additional care.
2. Oxygen therapy may be harmful under certain conditions. Patients shall correctly control oxygen flow and oxygen absorption time under the guidance of physician.
3. Excessive use of high-purity oxygen has toxic and side effect on human body.
4. People suffering severe carbon monoxide poisoning shall not use this product.
5. To prevent power failure or possible failure of oxygen concentrator, when the patients in urgent need of oxygen and the critically ill patients absorb oxygen using this product, other standby oxygen supply devices (e.g.: oxygen cylinder, oxygen bag, etc.) must be provided.
6. If the oxygen concentrator can not work properly, or if you feel uncomfortable, please stop using immediately and consult physician or supplier to solve the problems.
7. Oxygen is a kind of combustion supporting gas, thus the oxygen concentrator can not be used in places with open flame or the danger of flammability, smoking or open flame is prohibited near people who absorb oxygen.
8. Power supply must comply with electrical safety regulations. Oxygen concentrator shall not be used when power supply protective earth terminal doesn't comply with the regulations, otherwise it may cause personal injury.
9. Repairs must be performed by the company authorized service personnel only. Unauthorized service could cause injury, invalidate the warranty, or result in costly damage.

11. Symbols and Meanings for Security Requirements

	Warning	CE 0123	CE mark
	Type BF applied part		Class II equipment
O	Off (power)	I	On (power)
SN	Manufacture's serial number		Authorized representative in the European community
	Date of manufacture		Manufacture
	Can not be thrown into the trash		This way up
	Fragile		No smoking
	No open flame		Refer to instruction manual/ booklet.
IP21	Protected against access to hazardous parts with a finger. Protected against solid foreign objects of Φ 12.5mm and greater. Protected against vertically falling water drops.		Keep dry

10. Transportation and Storage

1. Attention



Attention

1. Before transportation or storage, pour out the water from humidifier bottle.
2. During transportation and handling, oxygen concentrator shall be kept upright, prohibit inversion or horizontal placing.
3. When the storage temperature is below 10 °C, place the oxygen concentrator in normal working environment for 8 hours before use.
4. If the oxygen concentrator not use for a long time, please inspect it to make sure all functions are normal before use again.

2. Requirements for storage and transportation environment

Ambient temperature	-20 °C ~ 55 °C ;
Relative humidity	≤ 93%;
Atmospheric pressure	500hPa ~ 1060hPa

3. Transportation

Oxygen concentrator packed completely shall be protected from violent collision and direct contact with rain or snow during transportation.

4. Storage

Oxygen concentrator shall be stored in indoor well-ventilated places without strong sunlight and corrosive gases.

3. Structural Features

Our oxygen concentrator mainly consists of machine, flow meter and humidifier bottle, as shown Figure 1.

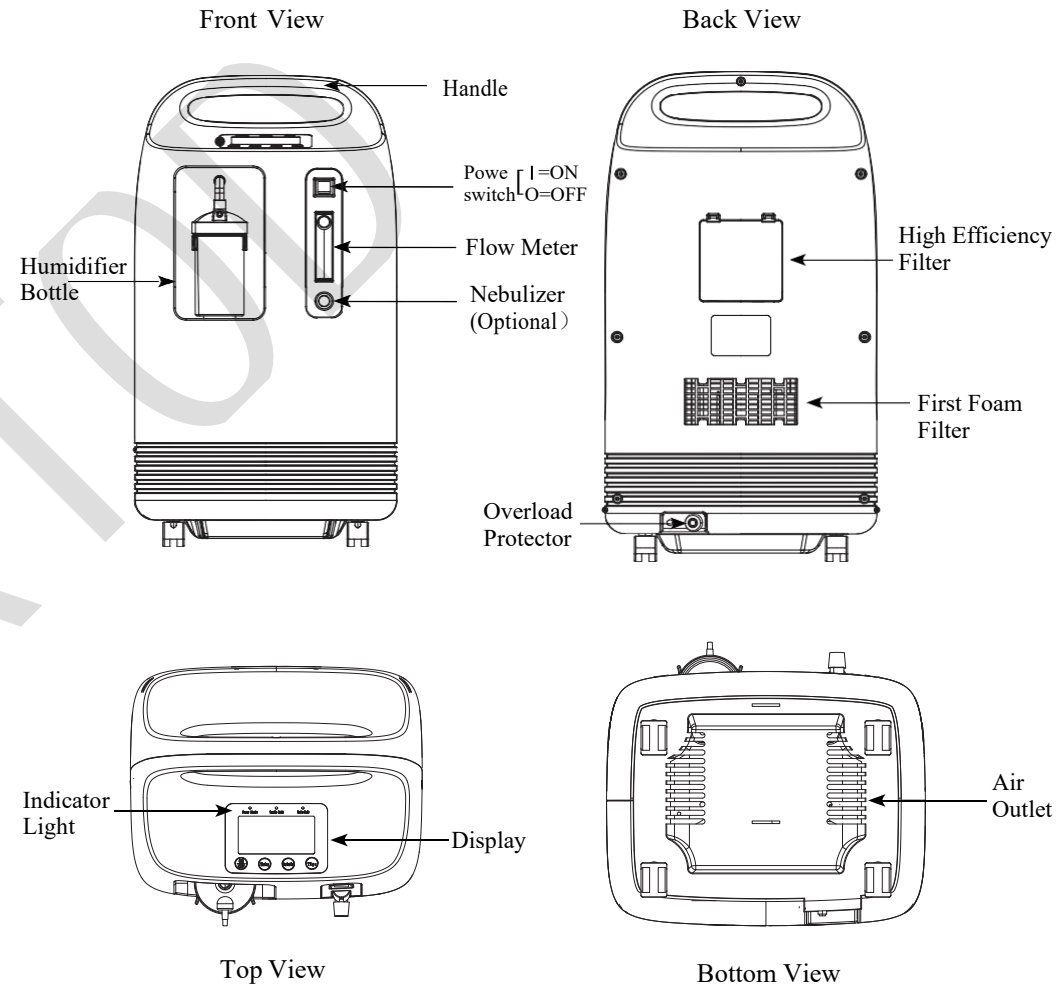

Figure 1

Overload protector: protect the machine from electricity overload.

Display: show the machine working status.

Air filter: prevents dirt, dust, and lint from entering your unit, include first foam filter and high efficiency filter.

4. Technical Indicators

1. Operating environment (oxygen concentration status indicator)

Ambient temperature: 10°C ~ 40 °C

Relative humidity: 30% ~ 75%

Atmospheric pressure: 860hPa ~ 1060hPa

Power supply: 220V ± 22V, 50Hz ± 1Hz/110v ± 15V, 60Hz ± 1Hz

There shall be no corrosive gas or strong magnetic field in surrounding environment.

2. Air requirements

Impurities in raw material air: ≤0.3 mg / cm³

Oil content in air: ≤ 0.01ppm

3. Product functions

Total working time: Show the total working time through display screen.

Timing: Set oxygen absorption time as required.

Automatic shutdown: Automatic shutdown after reaching preset oxygen concentration time.

Power failure alarm function.

Low voltage alarm function(optional).

Circulating pressure failure alarm function(optional).

Voice function.

Low oxygen concentration alarm function(optional).

Atomization treatment function (optional).

Remote control (optional)

a Stationary transmitters, such as wireless (cellular / cordless) telephones and terrestrial mobile radios base stations, amateur radio, AM and FM radio, television broadcasting, etc, their field strength are not theoretically predictable. In order to evaluate the electromagnetic environment of the stationary radio frequency transmitter, the electromagnetic field survey should be considered. If the field strength of place the oxygen concentrator located is higher than the above radio frequency coincident level, the oxygen concentrator should be observed to verify its normal operation, if abnormal performance is observed, supplementary measures may be necessary, such as to re-adjust the direction and position of the oxygen concentrator.

b in the entire frequency range of 150KHz-80MHz, the field strength should be less than 3V/m.

Table 4: Safe distance

Recommended isolation distance between portable and mobile radio frequency communication equipment and oxygen concentrator			
The oxygen concentrator is expected to be used in a radio frequency harassment controlled electromagnetic environment, depending on the maximum output power of the communication device, the purchaser or user of the oxygen concentrator can prevent electromagnetic interference by maintaining the minimum distance between the portable and mobile radio frequency communication equipment (transmitter) and the oxygen concentrator.			
Transmitter maximum rated output power W	Isolation distance (in meter) corresponding to the different frequencies of the transmitter		
	150KHz-80MHz d=1.2√P	80MHz-800MHz d=1.2√P	800MHz-2.5GHz d=2.3√P
0.01	0.12	0.12	0.23
0.1	0.38	0.38	0.73
1	1.2	1.2	2.3
10	3.8	3.8	7.3
100	12	12	23

For transmitter rated maximum output power not listed above, the recommended isolation distance (d) in meters (m) can be determined using the formula in the corresponding transmitter frequency column, where P is transmitter maximum output rated power provided by the transmitter manufacturer, in watts (W).

Note 1: At 80 MHz and 800 MHz frequencies, the formula for higher frequency bands should be used.

Note 2: These guidelines may not be suitable for all situations where electromagnetic propagation is affected by absorption and reflection by buildings, objects and the human body.

Table3: Electromagnetic immunity 2

Guide and manufacturer's statement -electromagnetic immunity			
Oxygen concentrator is expected to use in the following electromagnetic environment, buyers or users should ensure that its use in this electromagnetic environment			
Immunity test	IEC60601 test electrical level	Coincident electrical level	Electromagnetic environment - guidelines
Radio frequency conduction IEC61000-4-6 Radio frequency radiation IEC61000-4-3	3V(effective value) 150KHz-80MHz 3V/m 80MHz-2.5GHz	3V(effective value) 3V/m	Portable and mobile radio frequency communication equipment should not be closer than the recommended isolation distance to any part of the oxygen concentrator including a cable. The distance should be calculated using the formula corresponding to the transmitter frequency. Recommended distance $d=1.2\sqrt{P}$ $d=1.2\sqrt{P}$ 80MHz-800MHz $d=2.3\sqrt{P}$ 800MHz-2.5GHz in which: P - Transmitter maximum output power, in watts (W), provided by the transmitter manufacturer: D-Recommended isolation distance in meters (m). Fixed radio frequency transmitter field strength is determined through the investigation of electromagnetic fields, at each frequency. Should be lower than the recombination level. Interferences may occur near the devices marked with following symbol. 
Note 1: At 80 MHz and 800 MHz frequencies, the formula for higher frequency bands should be used			
Note 2: These guidelines may not be suitable for all situations where electromagnetic propagation is affected by absorption and reflection by buildings, objects and the human body.			

5. Product Installation

1. Unpacking inspection

Open the carton box from top of the packing box, and then take out the oxygen concentrator. Carefully check whether there is any transport damage to the machine and then check the accessories and relevant documents according to the packing list.

2. Installation precautions



Attention

- Oxygen concentrator shall be installed in indoor ventilating places without dust, corrosive, toxic or harmful gases or smoke. Avoid direct sunlight, and the distance from walls and other objects shall be greater than 10cm.
- Oxygen concentrator shall not be installed in places with open flame, fire source, danger of flammability or explosion, humidity, too high or too low temperature. Besides, it shall not be used in a closed room (space).
- No sundries, water or oil containers shall be placed on top of oxygen concentrator.
- Oxygen concentrator shall not be placed on soft surfaces (e.g. bed, couch) that may cause tilting or sinking, avoid shutdown or oxygen concentration decrease caused by too high temperature due to blockage of air inlet or outlet.
- Oxygen concentrator shall be placed smoothly, otherwise it will increase the noise during operation.
- If grid voltage is instable and exceeds the range of $220 \pm 22V$ or $110V \pm 15V$, please install voltage stabilizer before use.
- Please use safe and qualified socket and the wiring board with safe electricity certification.

6. Product Use

1. Use precautions



Attention

1. During use, ensure unobstructed exhaust at the bottom of oxygen concentrator, otherwise it may cause internal overheating.
2. When the output oxygen is less than the maximum recommended flow, oxygen concentration reaches 90%. When the flow exceeds the maximum recommended flow, oxygen concentration will decrease with the increase of flow.
3. Oxygen concentrator will reach the specified performance after started for 10 minutes.
4. There will be intermittent exhaust sound (every 6 seconds around) during operation of oxygen concentrator, which is normal.
5. No oil, grease or other similar substances shall be used on or near oxygen concentrator, and no lubricant other than those recommended by the manufacturer shall be used.
6. During use, timely add water when water level of humidifier bottle is below the minimum level.
7. On the atomization mode, machine can't be used for oxygen treatment.
8. Oxygen concentrator shall not be started frequently, it shall be restarted after stopped for 5 minutes.
9. When the oxygen concentration is abnormal, stop using, and contact the provider or manufacturer for inspection and maintenance.
10. Molecular sieve will become aging due to using time and environment etc., causing unrecoverable decrease of oxygen concentration amount. In case of this phenomenon, please contact the provider or manufacturer to replace the molecular sieve.
11. For long-term stopping of oxygen concentrator, be sure to unplug the power cord.
12. Before operating the unit please make sure the air inlet filter (on the back of unit) is clean .
13. If liquid is spilled on the device, turn the power off and unplug from electrical outlet before attempting to clean up spill.
14. If you feel discomfort or are experiencing a medical emergency while undergoing oxygen therapy, seek medical assistance immediately to avoid harm.
15. Do not share nasal cannula and humidifier with other people to avoid cross infection.
16. If the oxygen concentrator connected to the power, there should be people to take care of the machine.

Table 2: electromagnetic immunity 1

Guideline and manufacturer's statement-electromagnetic immunity			
Oxygen concentrator is expected to use in the following electromagnetic environment, buyers or users should ensure that its use in this electromagnetic environment			
Immunity test	IEC60601 test electrical level	Coincident electrical level	Electromagnetic environment - guideline
Electrostatic Discharge IEC61000-4-2	±6KVcontact discharge ±8KVair discharge	±6KVcontact discharge ±8KVair discharge	The floor should be wood, concrete or tile, if the ground covered with synthetic materials, the relative humidity should be at least 30%.
Electrical fast Transient IEC61000-4-4	±2KV to power line ±1KV to input/output line	±2KVto power line Not Applicable	The network power supply should have the quality that is used in a typical commercial or hospital environment.
Surge IEC61000-4-5	±1KV wire-to-wire ±2KV line-to-earth	±1KV wire-to-wire Not Applicable	The network power supply should have the quality that is used in a typical commercial or hospital environment
Voltage sag, short interruption and voltage change on power input line IEC61000-4-11	<5%UT, continue for 0.5 week (>95% sag on UT) 40%UT, continue for 5 weeks (60% sag on UT) 70% UT, continue for 25 weeks (30% sag on UT) <5%UT, continue for 5s (>95% sag on UT)	<5%UT, continue for 0.5 week (>95% sag on UT) 40%UT, continue for 5weeks (60% sag on UT) 70%UT, continue for 25 weeks (30% sag on UT) <5%UT, continue for 5s (>95% sag on UT)	The network power supply should have the quality that is used in a typical commercial or hospital environment. If the user of the oxygen concentrator needs continuous operation during the power interruption, it is recommended that the oxygen concentrator be powered by an uninterruptible power supply or battery.
Power frequency Magnetic (50/60Hz) IEC61000-4-8	3A/m	3A/m	The power frequency magnetic field shall have the characteristics of the 6 power frequency magnetic field level typical of a typical commercial or hospital environment.

Note: UT refers to the AC voltage applied before the test voltage.

9. Electromagnetic Environment Guidance



1. Pay attention to the on-site electromagnetic environment, the product may be affected by the field of electromagnetic fields. Product installation and use should be away from a strong magnetic wave emission products or facilities, such as the radio signal transmission tower, high-frequency electric knife, nuclear magnetic resonance equipment.

The product may also produce some electromagnetic interference to other electrical equipment on site, but the product meets the electromagnetic compatibility standards, the electromagnetic environment instrument is as shown in Table 1 - Table 4:

2. Portable and mobile communication RF equipment may affect the use of this product.

3. This equipment should not be used proximity to or stacked with other equipments, and if it must be near or stacked, verify that it is functioning properly in its intended configuration.

Table 1: Electromagnetic radiation

Guide and manufacturer's declaration - electromagnetic emission		
Oxygen concentrator is expected to use in the following electromagnetic environment, the purchaser or user should ensure that it is used in this electromagnetic environment		
Emission test	Conformity	Electromagnetic Environment - Guide
Radio frequency emission IEC/CISPR 11	1group	Oxygen concentrator uses RF energy only for other internal functions. Therefore, its radio frequency emission is very low, and the possibility of interference with nearby electronic equipment is very small.
Radio frequency emission IEC/CISPR 11	Class B	The oxygen concentrator is used in all facilities, including domestic facilities and directly connected to the public low-voltage power supply in residential buildings.
Harmonic emission IEC61000-3-2	Class A	
Voltage fluctuation/flicker emission IEC61000-3-2	Conform	

2. Operation

Control panel of oxygen concentrator is shown in Figure 2.

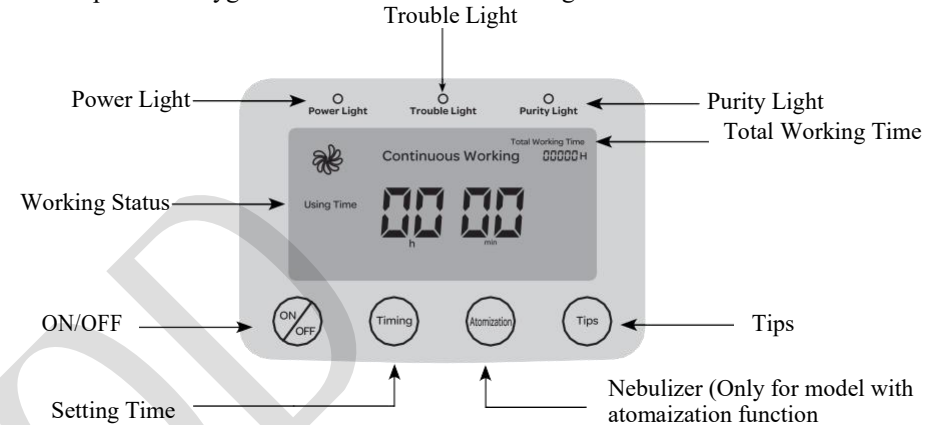

Figure 2

1. Select a location that allows the concentrator to draw in room air without being restricted. Make sure that the device is at least 10cm away from walls, furniture, and especially curtains that could impede adequate airflow to the device. Do not place the device near any heat source.

2. After reading this user manual, plug the power cord into a electrical outlet.

3. Do either Step ① or Step ② below.

① If you are not using a humidifier, connect your nasal cannula to a oxygen outlet port, as shown in the Figure 3.

② If you are using a humidifier, follow the steps below:

A. Fill the pure water (or distilled water) to your humidifier, the water level is between "Max" and "Min"

B. Lock the humidifier into the sunk part, then connect oxygen outlet port to the top of the humidifier, as shown in the Figure 4.

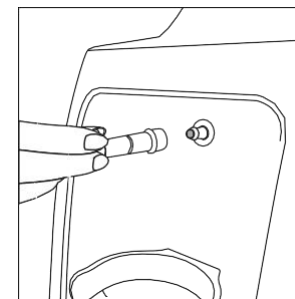

Figure 3

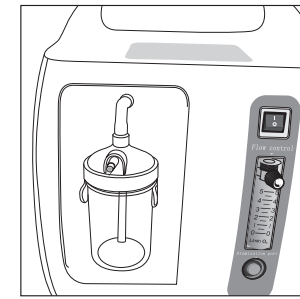

Figure 4

8. Technical Parameter

C. Connect your cannula to the humidifier bottle, as shown in the Figure 5

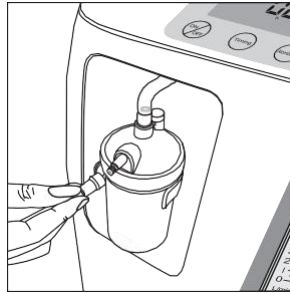

Figure 5

4. Press the power switch to the ON [I] position. Initially, the LED display will illuminate.
5. Press ON/OFF button, the device is turned on. You can begin breathing from the device immediately even though it typically takes mins to reach oxygen purity specifications. (Figure 6)
6. Adjust the flow to the prescribed setting by turning the knob on the top of the flow meter until the ball is centered on the line marking the specific flow rate. (Figure 7)

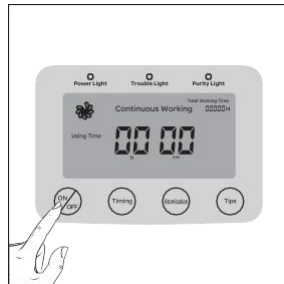

Figure 6



Figure 7

7. Put on the nasal cannula, then you can use machine properly.
8. When you are not using the oxygen concentrator, press the power switch to the OFF [O] position.

Model No.	OLV-3S	OLV-5S	OLV-10S
Maximum recommended flow	0-3L/Min	0-5L/Min	0-10L/Min
Oxygen concentration	93%±3%		
Power supply	220V ± 22V, 50Hz ± 1Hz/110v ± 15V, 60Hz ± 1Hz		
Output pressure	20Kpa-60Kpa		
Input Power	350VA	400VA	600VA
Whole machine noise	45dB(A)	45dB(A)	50dB(A)
Net Weight	21Kg	23Kg	28Kg
Dimension(MM)	350×250×670mm		
Working System	Continuous flow		
The sound pressure of auditory alarm signal	≥40dB		
Atomization quantity	≥0.15ml/min(Only modes with atomization function)		
Release pressure of air compressor safety valve	250kPa ± 50kPa		
Flow range when outlet nominal pressure is 7kpa	0-3L/min	0-5L/min	0-10L/min
Flow range when outlet nominal pressure is 0	0-3L/min	0-5L/min	0-10L/min
Device operation above or outside of the voltage, LPM, temperature, humidity and/or altitude values specified may decrease oxygen concentration levels.			

3. Clean of humidifier bottle

Remove humidifier bottle from the machine. Wash and clean it with warm water. In case of any water scale, rinse with clean water after descaling.

After cleaning, mix white vinegar with hot water in ratio of 1:3, soak the humidifier bottle in the mixture for 30 mins for sterilization.

During cleaning, pay attention to cleaning the small air hole at the bottom of the core tube in the bottle, so as to keep oxygen unobstructed.

Service: Don't remove the covers of this device. Only authorized provider or trained personnel of the manufacturer can perform maintenance.

3. Working mode:

① Continuous working mode:

Press the "ON/OFF" button, oxygen concentrator will be started and enters into "Continuous" working state. The LCD displays the total working time.

② Timer working mode:

After oxygen concentrator is started, press the "timing", oxygen concentrator will enter into timed working mode, for each press of "timing", preset time will be increased 30 minutes (minimum preset time is 1 hour, maximum preset time is 3 hours); Users can preset the time as required.

4. Function:

① Tips:

Press "Tips" button more than 3 seconds, to get instructions with voice.

② Atomize(atomization model only):

Press "Atomize" button, the machine will enter into atomize working state.

③ Automatic shutdown:

After reaching the preset time, oxygen concentrator will automatically shut down.

5. Defaults inspection and alarming signal

The oxygen concentrator will give audible and visual alarms when the alarms happen. Please deal with alarms immediately.

A. When power is lost for less than or equal to 30s, the alarm settings prior to the power loss shall be restored automatically

B. The oxygen concentrator is applied with the following default inspection functions

① Pressure, circulation defaults(optional).

② Compressor defaults.

③ Low oxygen concentration(optional).

1. The meaning of indicator lights

Symbols	Condition	Indicator lights	Audio indicator	Description
②	Good condition: oxygen concentration $\geq 82\%(\pm 3\%)$	Green	None	Normal oxygen output
⚠	$72\%(\pm 3\%) \leq$ oxygen concentration $< 82\%(\pm 3\%)$	Yellow	Intermittent alarming sound	Low oxygen output
🔊	System defaults 1) Oxygen concentration $< 72\%(\pm 3\%)$; 2) Pressure, circulation defaults alarming; 3) Compressor defaults alarming.	Red	Continuous alarming sound	Excessively low oxygen output; Critical fault of device.

2. Oxygen concentration alarm(optional)

- ① When the oxygen concentration $\geq 82\%(3\%)$ --- green light lightens, which means the machine operates smoothly.
- ② When $72\%(\pm 3\%) \leq$ oxygen concentration $< 82\%(3\%)$ --- yellow light lightens, please contact with the supplier immediately. User can temporarily use the machine, and please ensure there is standby oxygen.
- ③ When oxygen concentration $< 72\%(\pm 3\%)$ --- the red light lightens with continuous alarming sound, the machine stops. Please power off the machine immediately and use the standby oxygen, contact with the provider as soon as possible.

NOTE: every time the oxygen concentrator starts, it will be in the most stable condition after about 30 minutes.

3. Pressure, circulation defaults alarming --- the red light lightens with continuous alarming sound, the machine stops. Please power off the machine immediately and use the standby oxygen, contact with supplier as soon as possible.

7. Cleaning & Maintenance

Warning: It is important to unplug the device before the cleaning and maintenance of oxygen concentrator.

Caution: Excess moisture may impair the proper operation of the device.

1. Clean of Device:

Periodically use a damp cloth to wipe down the exterior case of this device.

2. Clean or replace the filter

The cleaning and changing of filter is very important for protecting compressor and molecular sieve and extending the working time of oxygen concentrator. Please timely clean and replace according to requirements.

WARNING: Oxygen concentrator shall not be started before filter are installed.

① Clean of first foam filter.

The first foam filter should be cleaned once a week. During cleaning, draw out foam filter and rinse with clean water, it can be used after natural drying.

② Replace of high efficiency filter(Called Hepa filter)(Figure 8)

When the machine total working time reach to 3000 hours. The user has to replace the Hepa filter. Open the filter window, remove the high Hepa filter, and then replace with a new one.

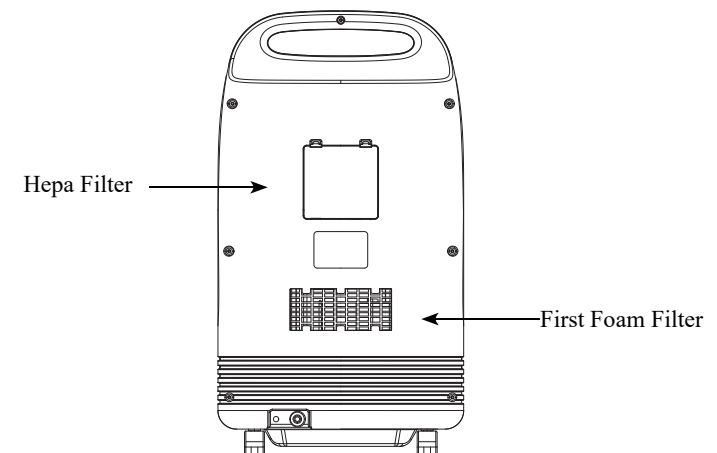

Figure 8