



# E-bike Kits

# User Manual

For Rear Motor With Cassette Freewheel

YOSE POWER

Appreciate for purchasing YOSE POWER electric bicycle Kits

**Please turn to page 2 to obtain the user manual in English. ----- 02**

Vielen Dank für den Kauf des Yongsheng Elektrofahrrad-Kits

**Um das deutsche Handbuch zu lesen, gehen Sie bitte auf Seite 6 ----- 06**

Merci d'avoir acheté les e-bike kits de YOSE POWER

**Pour lire le manuel en français, veuillez vous rendre à la page 10 ----- 10**

Gracias por comprar el kit de bicicleta eléctrica YOSE POWER

**Para leer el manual en español, vaya a la página 14 ----- 14**

When you install the product, please make sure that you observe all instructions provided by the user manual. It is suggested that you use all components provided by yosepower. Serious injuries may be incurred due to damaged screws or because the nuts suddenly malfunction.

- Please make sure that you wear a goggle or other eye goggle device when you are repairing the bike or replacing components.
- If the content of the user manual does not include your product, please browse the official website – [www.yosepower.com](http://www.yosepower.com), or contact the yosepower team.
- Please put the user manual in the proper place for reference in the future.

## Notices of user manual

Please add the following items when our system users provide the descriptions written by themselves :

- Please do not pay too much attention to the screen of the E-Bike display when you are riding the bike, or accidents may be incurred.
- Please do check the wheels sets and the tires are correctly installed on the bike. Serious injuries may be incurred if you fail to confirm that these components are correctly installed on the bike, or contact the yosepower team for assistance.
- When you are riding the E-Bike, you should be very familiar with the characteristics of the bike being activated or deactivated.
- If the bike is suddenly activated but you are not familiar with these characteristics, accidents will be incurred.
- Please turn on the light if you ride the bike at night or in the place without sufficient light provision.

## Important information

- Please observe the safety instructions of the user manual for your safety.
- When using the product, please observe the safety instructions provided by the safety inspector or the user manual, the product is not suitable for mental disabled, physical disable or people without bicycle riding experience and relevant knowledge, including children.
- Please do not modify the system. The system will be out of order if you improperly modify the system.
- Please contact for help about the installation and the adjustment of the product yosepower team.
- The product is designed to be have the completely water-proof function and can be safely used in moist places. However, please do not immerse the product into water on purpose.
- Please do not use high-pressure water jet to wash the bike. If water contacts the components, the bike will be out of order and the components will be rusted.
- Please handle product with care to prevent from serious impact.
- Some safety instructions of the user manual can be also seen in the relevant warning marks on the product.
- Please contact yosepower for any questions about maintenance team.
- Abrasion due to normal use is not within the warranty range provided by us.

## E-Bike assembling & repair guide

- Please remove the battery before you install the components and the cables of the E-Bike in order to prevent from accident.
- When you install the E-Bike, please make sure that you observe all instructions of the user manual. If the screws and nuts are not correctly tightened or the components are damaged, the E-Bike may fall over and serious injuries may be incurred.
- The frequencies of maintenance and repair will be different according to the usage situation of the E-Bike. The system of the bike should be periodically cleaned by the proper cleaning products. If you need to clean the bike, please use a neutral detergent and soft cloth or low-pressure water jet to wash the bike, and the dry the bike. Please properly use the suggested oils to lubricate the rotational components.

## Tools and Packing Components

Installation tool	Components	
Adjustable wrench	Hub motor with wheel	
Freewheel chain wrench	Waterproof connection cable (4 in 1)	
Cross screwdriver	Controller	LCD display
Cassette freewheel sleeve	PAS Sensor	Controller bag
Hex wrench	Thumb throttle	Brake lever
Puller		

## Kits connection diagram

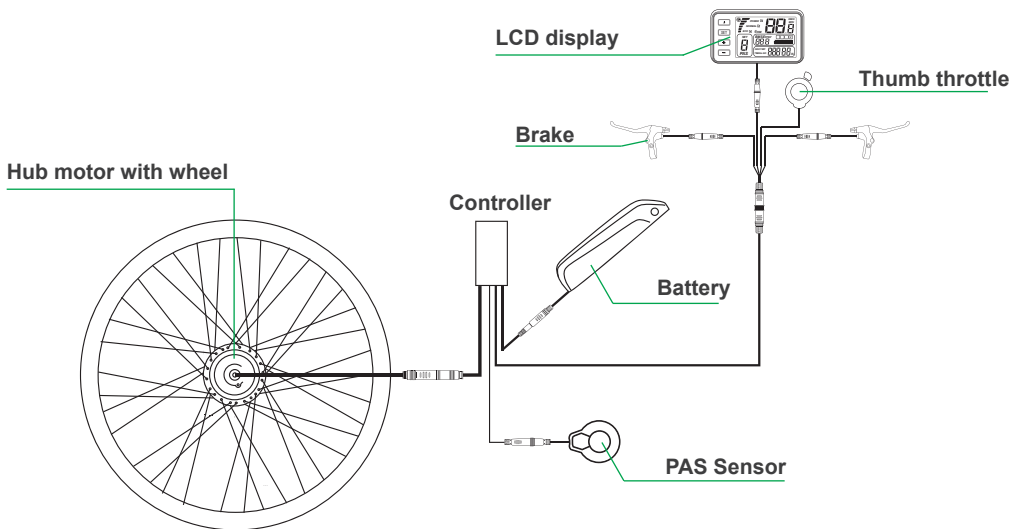

- Photo 1: Take out the original rear wheel
- Photo 3-5: Use freewheel sleeve, adjustable wrench, chain wrench to unscrew the freewheel cover, then take out the freewheel.
- Photo 6-8: Place the freewheel into the motor tagee, then to use freewheel sleeve, adjustable wrench to fasten it.

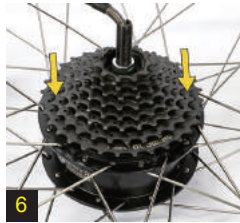

## Brake disk/Tire installation

- Photo 1: Unscrew the original brake disc and then install it on the motor with the hex wrench (**Attention: Please use the screws from the motor to fasten the disc, otherwise the motor may not work properly**).
- Photo 2,3: Remove the original tire and guard ring, install them on the motor wheel (**The guard ring can protect the tire**).
- Photo 4: Install the original tire to the motor hub.



- Photo 1: place the washer(**with part bulge**), shim, and nut in sequence into both sides of the motor axle.
- Photo 2~4: Put the rear wheel into the rear fork, place the washer between the motor and fork, then use the wrench to fasten the nut. Please note the motor cable should face down, cover the waterproof plug, waterproof and dustproof.

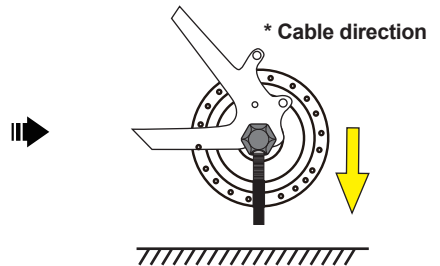
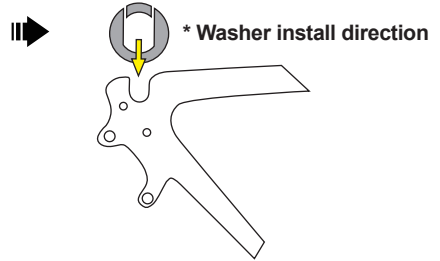
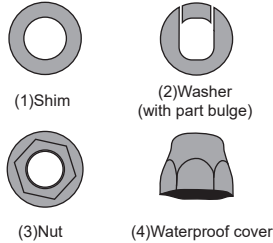
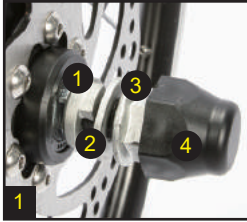

## Brake Lever and Throttle installation

- Put the brake bar to the handle bar and adjust it to a comfortable position, then use the hex wrench to fix it.
- Photo 1,2: Pull out the original brake line of bike, then connect the line to the new brake lever.
- Photo 3,4: Place throttle on the right side of the bar, find a comfortable position and fasten it with hex wrench.



- Put the display on the left handle bar and fix it in a comfortable position.
- Please re-set the data of wheel diameter otherwise it will affect the speed showing (default value: 26 inch)

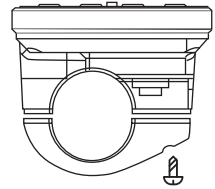
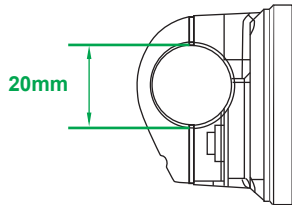
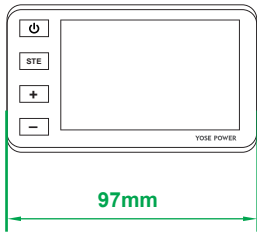

## Install the PAS in the left pedal side

- Use puller and hex wrench to take off the left crank, then install the pass sensor (**Attention: the pass sensor spline must be matched well with crank spline**), finally install and fasten the left crank.



**At last, install the battery and controller in the right position, and connect all connectors, then your e-bike has been done.**

## Benötigtes Werkzeug und Lieferumfang

Benötigtes Werkzeug	Lieferumfang	
Verstellbaren Schraubenschlüssel	Hub motor Rad	
Ketten Peitschen	Wasserdichtes Kable (4 in 1)	
Kreuzschraubendreher	Controller	LCD Display
Freilauf Steckschlüssel	PAS Sensor	Controller Tasche
Imbusschlüssel	Daumengas	Bremshebel
Abzieher		

## Kits connection diagram

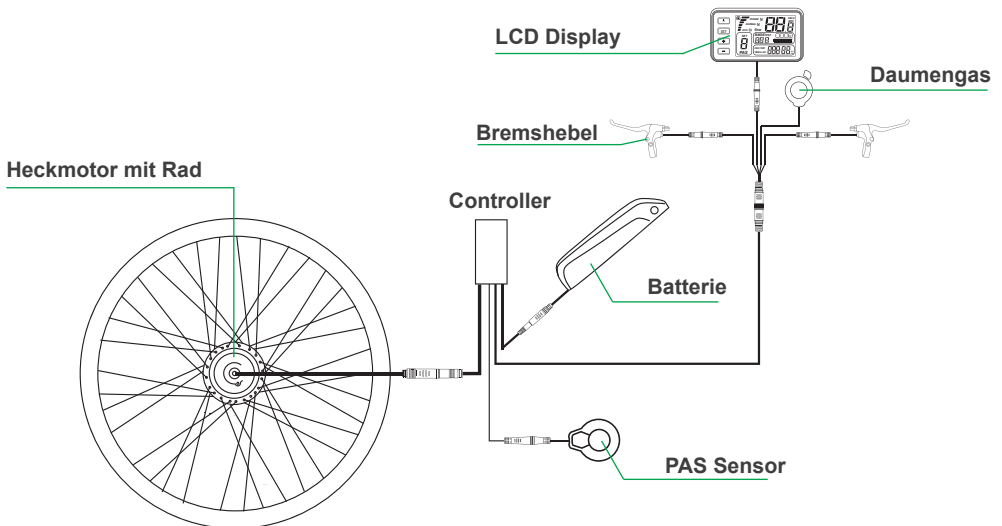



- Bild 1: Demontieren Sie das originale Hinterrad.
- Bild 3~5: Mit Freilauf Steckschlüssel, Verstellbaren Schraubenschlüssel und Ketten Peitschen schrauben Sie die Abdeckung des Steckkranzes und nehmen Sie den Steckkranz aus.
- Bild 6~8: Setzen Sie den Schraubkranz auf Motor, mit Freilauf Steckschlüssel und Verstellbaren Schraubenschlüssel den Schraubkranz zu befestigen.



## Montage der Bremsscheibe/Reifen

- Bild 1: Demontieren Sie die Bremsscheibe. Dann montieren Sie sie mit Imbusschlüssel auf den Motor.  
**(Hinweis: Bitte verwenden Sie zur Befestigung der Bremsscheibe die Originalschrauben am Motor,sonst funktioniert der Motor möglicherweise nicht. )**
- Bild 2,3: Demontieren Sie den originalen Reifen.Bringen Sie den originalen Schutzring auf die neue Felge **(dies dient zum Schutz des Fahrradreifens)**
- Bild 4: Montieren Sie den originalen Reifen auf der Radnabe.



- Bild 1: Legen Sie nacheinander auf beide Seite der Motorlage die Sicherungsscheibe Unterlegscheibe und Radmutter.
- Bild 2~4: Legen Sie das Rad in die Gabelhalterung. Dann legen Sie zwischen dem Motor und Gabelhalterung die Sicherungsscheibe und befestigen die Radmutter. Hinweis: Die Richtung des Motorskabel ist nach unten.

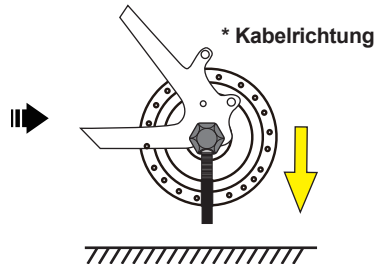
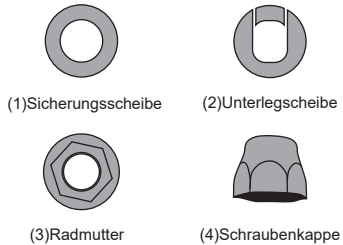
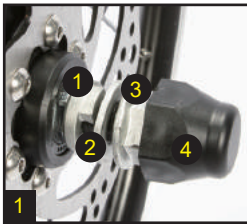

## Montage der Bremshebel und Daumengas

- Geben Sie auf jede Seite des Lenkers einen Bremshebel. Finden Sie, die für Sie angenehmste Position am Lenker und fixieren Sie die Bremshebel mit Imbusschlüssel.
- Bild 1,2: Ziehen Sie das Originalbremskabel ab und verbinden Sie das Kabel dann mit dem neuen Bremshebel
- Bild 3,4: Montieren Sie den Gashebel und fixieren diesen mit Imbusschlüssel



- Montieren Sie die Halterung für das LCD Display in der linken oder rechten Lenkstange.
- Bitte stellen Sie die richtige Radgröße ein, sonst wird die falsche Geschwindigkeit gezeigt.

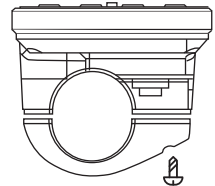
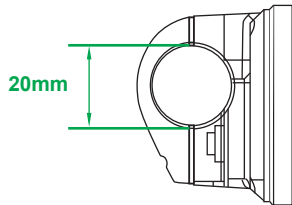
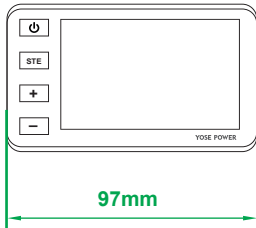

## Montage des PAS auf der linken

- Montage des PAS auf der linken Seite  
Entfernen Sie mit Abzieher und verstellbaren Schraubenschlüssel die linke Pedalkurbel.
- Montieren Sie den PAS Sensor. **(Achten Sie auf die Achseverzahnung und die zu befestigende Sensorverzahnung).**
- Montieren und befestigen Sie die linke Pedalkurbel.



Installieren Sie schließlich den Akku und den Controller in der richtigen Position und schließen Sie alle Anschlüsse an, und Ihr Elektrofahrrad ist fertig

## Outils d'Installation et Liste de Produits

Outils d'Installation	Composants	
Clé à molette	Moteur de moyeu avec roue	
Clé à Chaîne à Roue Libre	Câble étanche (4 en 1)	
tournevis cruciforme	contrôleur	l'écran LCD
Manchon de roue libre de cassette	PAS Capteur	Sac de contrôleur
clé six-pans	manette de gaz au pouce	les freins
l'extracteur		

## Schéma de Connexions du Kit

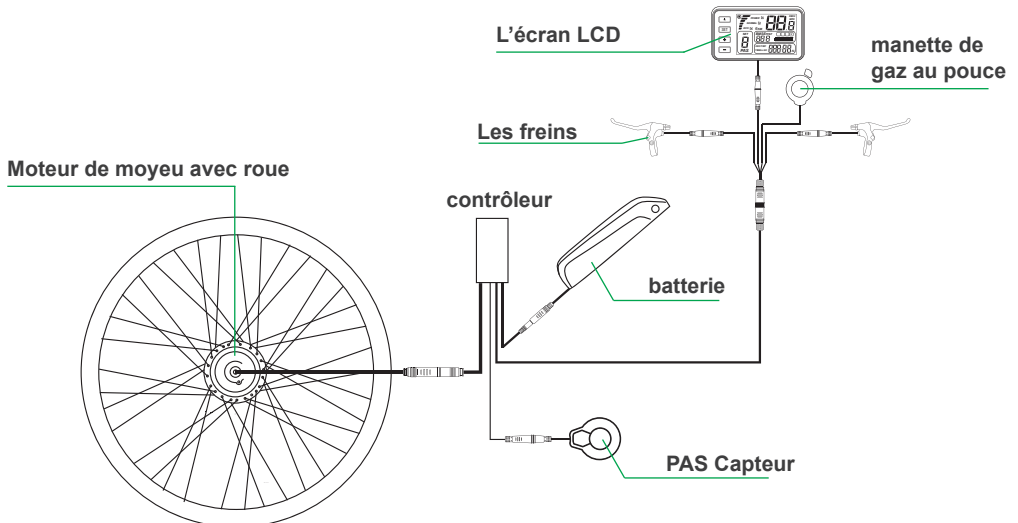



- Figure 1: Démontez la roue arrière d'origine du vélo
- Figure 3~5: Utilisez un manchon de roue libre de cassette, une clé à molette et une clé à chaîne pour dévisser le couvercle de la cassette de roue libre, puis retirez la cassette.
- Figure 6~8: Placez la cassette sur le moteur tagée, puis utilisez le manchon de roue libre et la clé à molette pour la fixer.



## Installer disque de frein/pneu

- Figure 1: Démontez le disque de frein. Montez-le ensuite sur le moteur avec une clé six-pans. **(Remarque : veuillez utiliser les vis d'origine pour fixer le disque de frein au moteur, sinon le moteur pourrait ne pas fonctionner.)**
- Figure 2, 3: Démontez le pneu d'origine et placez l'anneau de protection d'origine sur la nouvelle jante (c'est pour protéger le pneu de vélo)
- Figure 4: Montez le pneu d'origine sur la jante du moteur



- Figure 1: Placer la rondelle frein, la rondelle et l'écrou sur les deux côtés de l'arbre du moteur à tour de rôle.
- Figure 2 ~ 3: Placer la roue fermement dans la fourche arrière. Placer ensuite la rondelle frein entre le moteur et la fourche et serrer l'écrou.  
Remarque: Le sens du câble moteur est vers le bas, couvrir avec un couvercle en caoutchouc, imperméable et anti-poussière.

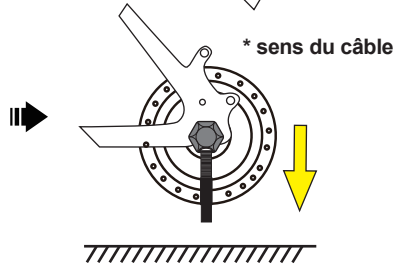
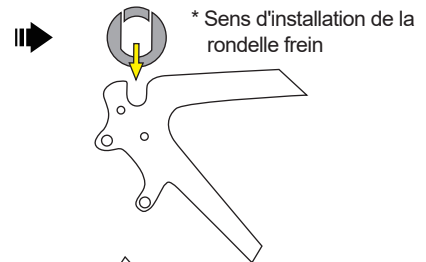
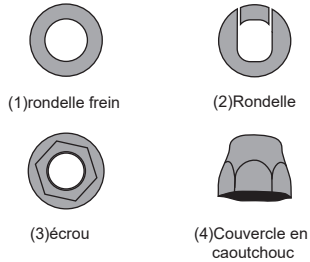
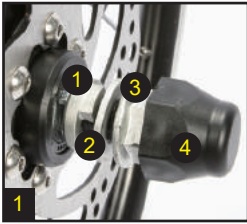

## Installer le levier de frein et la manette des gaz

- Placer un levier de frein de chaque côté du guidon. Trouvez la position la plus confortable pour vous sur le guidon et fixez les leviers de frein avec une clé six-pans.
- Figure 1 ~ 2: Débrancher le câble de frein d'origine, puis connecter le câble au nouveau levier de frein.
- Figure 3~ 4: Placer la manette des gaz et la fixer avec une clé six-pans.



- Placer le support de l'écran LCD sur le guidon gauche ou droit, Serrez après avoir trouvé une position confortable.
- Veuillez définir la bonne taille de roue, sinon la mauvaise vitesse sera affichée.  
(Le paramètre par défaut: 26 pouces,veuillez le définir en fonction de la taille du kit acheté.)

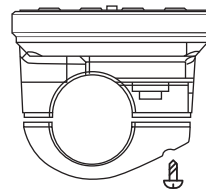
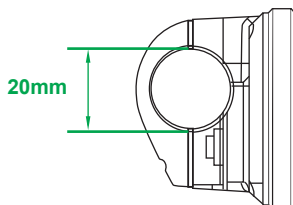
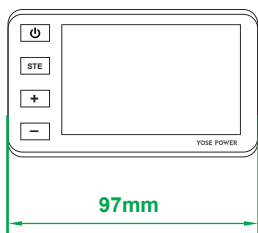

## Installer le PAS à gauche

- A l'aide de l'extracteur et de la clé à molette, démontez la manivelle gauche. Alors installez le capteur PAS. (Remarque : La cannelure du boîtier de pédalier et la cannelure du capteur doivent être alignées puis installées fermement.) Enfin assemblez et fixez la manivelle de pédale gauche.



Enfin, installez la batterie et le contrôleur dans la bonne position et branchez tous les câbles, et votre vélo électrique est prêt.

## Lista de herramientas y productos

Herramienta de instalación	Material	
Llave inglesa	Motor de cubo con rueda	
Freewheel chain wrench	Cable de conexión impermeable (4 en 1)	
Destornillador cruzado	Controlado	Pantalla LCD
Cassette freewheel sleeve	PAS Sensor	Bolsa de controlador
Llave hexagonal	Acelerador	Freno de mano
Herramientas para tirar		

## Diagrama de instrucciones de conexión del kit

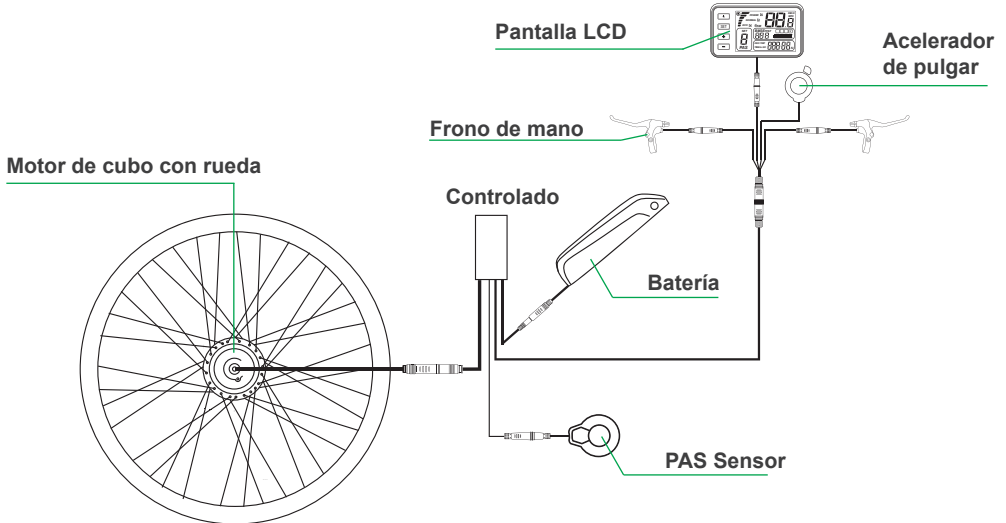



- Foto1: Saca la rueda trasera de la bicicleta original.
- Foto 3-5: Utilice un manguito de rueda libre, una llave ajustable, una llave de cadena para desenroscar la cubierta de la rueda libre y luego saque la rueda libre.
- Foto 6-8: Coloque el volante en la base del motor y luego use el casquillo del volante y la llave ajustable para apretar el volante.



## Disco de freno / instalación de neumáticos

- Foto 1: Desatornille el disco de freno original y luego instálelo en el motor con la llave hexagonal. **(Atención: utilice los tornillos del motor para sujetar el disco, de lo contrario, es posible que el motor no funcione correctamente)**
- Foto 2-3: Retire el neumático original y mueva el anillo protector original a la nueva llanta **(para proteger el neumático de la bicicleta)**
- Foto 4: El neumático original está instalado en el cubo del motor.



- Foto1: coloque arandela(**parcialmente saliente**), arandela y tuerca en secuencia en ambos lados del eje del motor.
- Foto 2-4: Coloque la rueda trasera en la horquilla trasera, coloque arandela(**parcialmente saliente**) entre el motory la horquilla, luego use la llave para apretar la tuerca.  
Nota: Tenga en cuenta que el cable del motor debe mirar hacia abajo, cubrir la tapa impermeable.

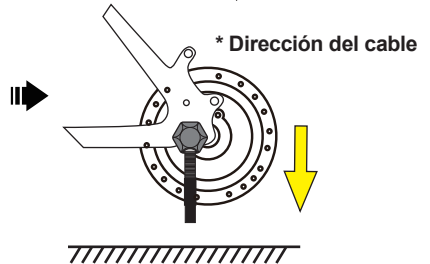
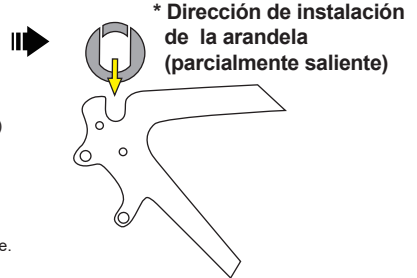
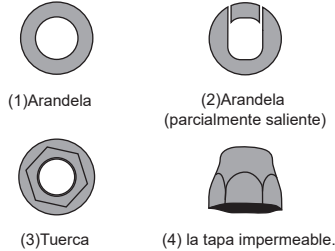
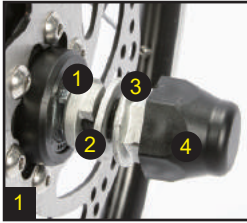

## Instale la palanca de freno y el acelerador

- Coloque la barra de freno en el manillar y ajústela a una posición cómoda, luego use la llave hexagonal para fijarla.
- photo1-2: Extraiga la línea de freno original de la bicicleta, luego conecte la línea a la nueva palanca de freno.
- photo3-4: Coloque el acelerador en el lado derecho de la barra, encuentre una posición cómoda y fíjela con hex llave inglesa.



- Coloque la pantalla LCD en el asa izquierda y aprétela después de encontrar una posición cómoda.
- Vuelva a configurar los datos del diámetro de la rueda; de lo contrario, afectará la velocidad que se muestra (**valor predeterminado: 26 pulgada**)

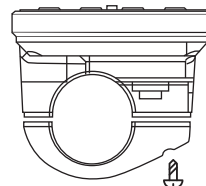
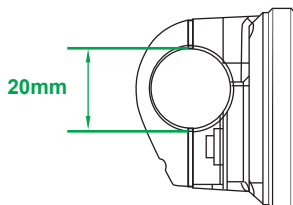
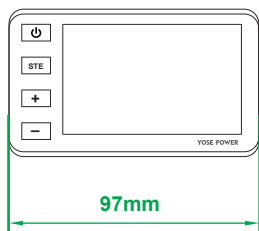

## Instale PAS en el lado izquierdo del pedal

- Use Herramientas para tirar y una llave hexagonal para quitar la manivela izquierda, luego instale el sensor PAS (**Atención: la ranura del sensor PAS debe coincidir bien con la ranura de la manivela**), finalmente instale y apriete la manivela izquierda.



Finalmente, instale la batería y el controlador en la posición correcta, y conecte todos los conectores, su bicicleta eléctrica está completa.



<https://bit.ly/2z4sPn2>

Watch the installation video on youtube yosepower official channel



**Official online shop**

<https://yosepower.com/>

## Marking



EUBRIDGE ADVISORY GMBH  
Virginia Str. 2 35510 Butzbach,Germany eubridge@outlook.com Tel: 004915731153070



TANMET INT'L BUSINESS LTD  
9 Pantygraigwen Road, Pontypridd, Mid Glamorgan, CF37 2RR,UK tanmetbiz@outlook.com  
Tel: 00442922550866



Batt-Reg.-Nr.DE 10983121  
VerpackG:DE 5677895103216  
WEEE-Reg-Nr:DE 31838004



**YOSE POWER CO.,LTD.**

Add: Changxing County, Zhejiang Province, China.  
E-mail:service@yosepower.com