

AIR PURIFIER

INSTRUCTION MANUAL

AIR PURIFIER

Model: Fillo

Thank you very much for using our products.
Please read the user manual carefully before use, and keep it for future reference.

v1

Zhongshan Invitop Electrical Co., Ltd
BF6 No.6 Xinhua Road Sanjiao Town Zhongshan City Guangdong China

CONTENT

Points for Attention	01
Product Overview	02
Specifications	04
Installation Filter	04
Function Instruction	06
Maintenance	08
FAQ	09

POINTS FOR ATTENTION

Before using, please read this user manual carefully and keep it for future reference.

Warning

- To avoid electric shock and fire, do not allow water, liquid or any flammable detergent to get into or to clean the product.
- Do not spray insecticide, perfume or other flammable spray around the products.
- Before connecting the power supply, please check whether the voltage of the product is consistent with the local power supply voltage.
- This product can not replace normal ventilation, daily dust collection or oil pumping when cooking.
- Ensure the product is used in condition of a stable and horizontal level.
- Leave at least 30cm of space on the back and sides of the product, and at least 50cm of space above the product when using.
- Ensure both the filter and its cover are properly installed before using.
- Do not insert finger or other things into the air outlet/inlet to prevent physical damage or trouble.

-01-

PRODUCT OVERVIEW

Components

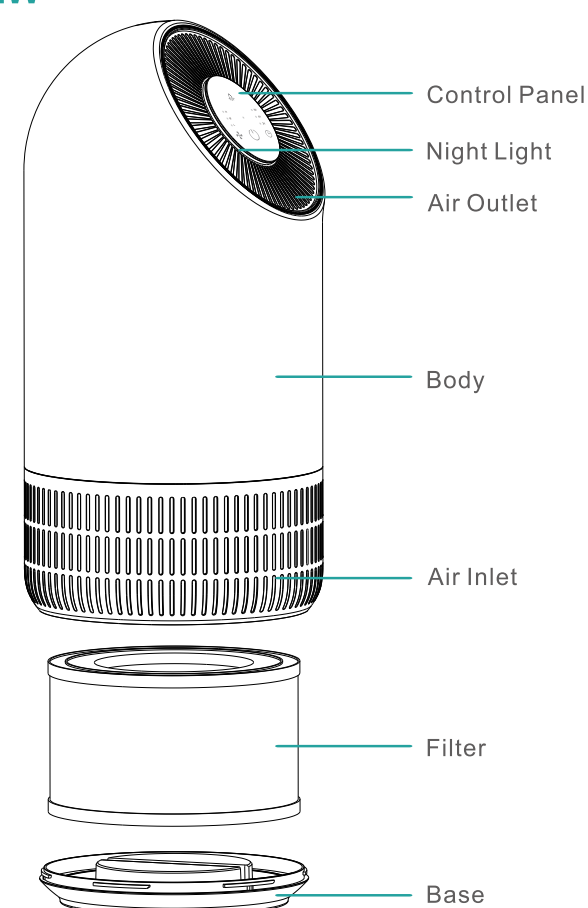

-02-

Control Panel

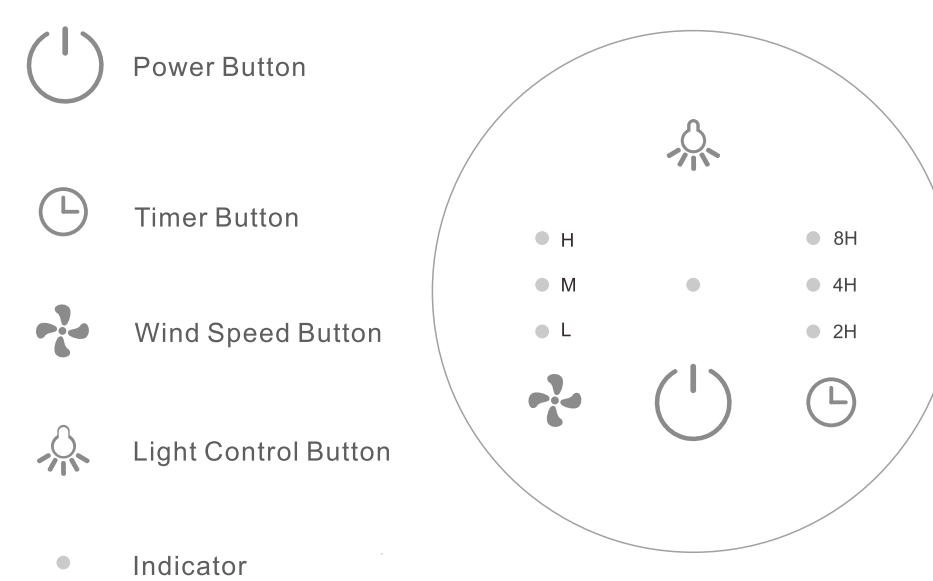

-03-

SPECIFICATIONS

Model No.	Fillo
Size	195*195*403mm
Net Weight	2.3kg
Input	AC120V 60Hz
Power	35W
CADR	90m ³ /h
Coverage Area	≤11m ²

INSTALLATION FILTER

Notice

- Please remove the packaging of the filter before using for the first time.
- Ensure the machine is unplugged before removing or installing the filter.
- When the power indicator keeps flashing in red, the filter should be replaced.
- Please wipe the dust on the filter regularly, do not wash or use it repeatedly.
- Please use the filter specially designed for this product.

-04-

Steps of Installing Filter

Unplug the power socket of the machine before replacing or installing the filter.

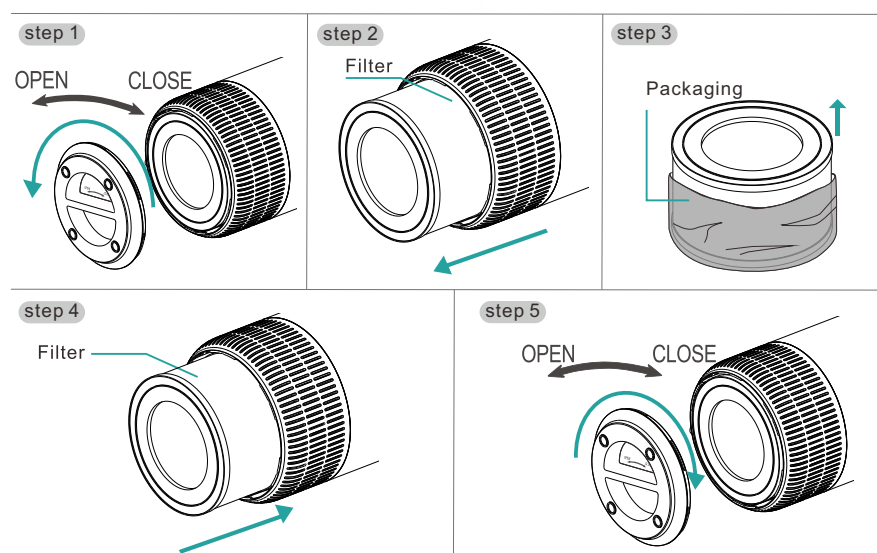

- Invert the machine, and rotate the base along the direction marked "OPEN".
- Take out the filter from the machine.
- Remove the packaging of the filter.
- Install the filter into the machine.
- Then Install the base, rotate and tighten the base along the direction marked "CLOSE".

-05-

FUNCTION INSTRUCTION

When connect to the power socket, the buzzer will ring for 1 second.

Button Operation

Power Button

- In the condition of working, touch the power button to turn on the machine, the buzzer will ring for one time, the power indicator and the low grade of wind speed indicator light turns green.
- Touch the button again, the buzzer will ring for one time and the machine will turn off with all lights turn off.

Notice: The machine will record the working modes when turns off without unplugging the power socket.

Timer Button

- In the condition of working, press the timer button to set among the circulation of 2H, 4H and 8H timer with buzzer rings, and the corresponding indicator will be on.
- Press again, the timer indicator turns off and the machine will work continuously without timer.
- In the status of timing, the machine begins to count down. When the time is up, the fan will stop working and all lights will be off.

Notice: The timer button couldn't operate in the status of shutdown.

-06-

Wind Speed Button

- In the condition of working, press the wind speed button, the buzzer will ring for one time.
- Press again to adjust the wind speed among the circulation of Low grade, Middle grade and High grade with buzzer rings, the corresponding indicator will be on.

Notice: The wind speed adjustment couldn't operate in the status of shutdown.

Light Control Button

- In the condition of working, touch the light control button, the light degree can be set between soft light and standard light mode with buzzer rings.
- Touch again, the LED light turns off.

Notice: The light control button couldn't operate in the status of shutdown.

Reminder of Replacing Filter

When the machine detects the filter is saturated, the power indicator will keep flashing in red. Please press the power button for 7s to reset after installing a new filter.

-07-

MAINTENANCE

Note

- Ensure the machine is unplugged before maintenance.
- Do not immerse the machine into water or any liquid.
- Do not use abrasive, corrosive or flammable cleansers (such as bleach or alcohol) to clean any part of the unit.
- Don't use a vacuum cleaner to clean the filter or wash it directly.
- Please sterilize the filter under sunlight regularly.

Cleaning & Storage

- Ensure the machine is power-off and unplugged.
- Use a soft cloth with neutral cleanser to clean away any dust or debris from the surface of the unit and air inlet/outlet.
- After the machine completely dry out, put on the bag and place it in a cool and well ventilated place.
- If you do not use it for a long time, in the basic of previous steps, please turn on the machine for a few minutes from time to time to ensure a good performance.

Notice: Please don't drop any water into the machine when clean the air outlet.

-08-

FAQ

SITUATION	REASON
No working	<ul style="list-style-type: none"> Is it plugged into a power socket? Is there a power outage? Is the home leakage switch or fuse cut off? Is the filter replacing indicator keep flashing?
Poor performance	<ul style="list-style-type: none"> Is there any dust in the surface of pre-filter? Is there any obstacle blocking the air inlet/outlet.
Significant noise	<ul style="list-style-type: none"> Is there anything stuck on the fan in the air outlet? Is the machine tilted? Please set a lower grade of wind speed if the noise is too loud, or set low grade of wind speed when using in bedroom at night.
Coming out nasty smell	<ul style="list-style-type: none"> It is the normal phenomenon that the machine emits the smell of plastic for the first time. The machine will emit nasty smell if the filter is dusty, so in this situation, please clean or replace the filter. If the burning smell emits from the machine, please unplug the power socket and contact with buyer or customer service.
The reminder of replacing filter is still flashing after user have replaced a new one.	<ul style="list-style-type: none"> Please press the power button (⏻) for 7s to reset the machine and the life counter of the filter will start.

Notice: If the above FAQ can not solve your problems and need maintenance, please contact the supplier or after sales service center. Please do not disassemble the machine to maintain by yourself.

-09-