

Network Video Recorder System Assure K31

QUICK GUIDE

Please read this quick manual thoroughly before using this product and keep it for future reference.

For more detailed instructions, please contact us at support@heimvision.com



We will regularly update the user manual, please scan the QR code or visit <https://www.heimvision.com/pages/download> for the latest version if it's available.

SAFETY CAUTIONS	01
ABBREVIATIONS OR TERMS	01
PACKING LIST	02
PRODUCT OVERVIEW	03
INSTALLATIONS AND CONNECTIONS	04
HDD Installation(Optional)	04
System Connections	05
Camera Installation.....	07
OPERATE NVR SYSTEM ON A MONITOR	09
Live Picture	09
HDD Formatting	09
Video Recording.....	10
Video Playback.....	11
Alarm Setting	13
Audio In and Out.....	15
Video Backup	16
Network Setup	17
Functions on the Menu Bar.....	18
OPERATE NVR SYSTEM FROM ESEECLOUD ON PC	19
EseeCloud Login.....	19
Video Playback and Backup	22
Other Functions of the Bottom Menu	24
OPERATE NVR SYSTEM ON A MOBILE DEVICE	25
App Installation.....	25
Connecting the NVR system.....	25
OPERATE NVR SYSTEM FROM A BROWSER ON PC	29
EXTEND THE WIFI RANGE.....	30
ADD OR DELETE CAMERAS.....	33
TROUBLESHOOTING GUIDE	36
SPECIFICATIONS	40

SAFETY CAUTIONS

1. Please do not place any container with liquid such as water, coffee, or beverage on the NVR.
2. Please put the NVR at a ventilated space and do not block the air vents.
3. For the system security, please use the original power supply provided.
4. Check the power voltage in case of any damage due to the wrong voltage.
5. Please obey the local security regulations and policies when installing the product.
6. If the NVR starts or works abnormally, please unplug the power adapter and carefully clean the dust on the mainboard in the NVR device, then restart the NVR.
7. We assume no liability or responsibility for any fires or electrical shock caused by improper installation.

ABBREVIATIONS OR TERMS

NVR: Network Video Recorder

HDD: Hard Disk Drive

SATA: Serial ATA, a common hardware interface employed by our NVR.

EseeCloud: A software designed for this product.

FAT32: A file system of your USB Drive.

PACKING LIST

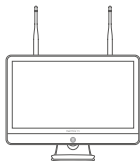

NVR x1
(HDD Optional)

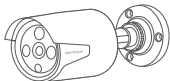

IP Camera x4



5dB Antenna x4
(for IP Camera)



USB Mouse x1



DC 12V/3A
Power Adapter x1
(for NVR)

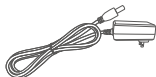

DC 12V/1A
Power Adapter x4
(for IP Camera)



Ethernet Cable x1



Screw for HDD x4
(Optional)



Screw Kit x4
(for IP cameras)



Waterproof
Connector x4
(Optional)



Quick Guide x1

* If there is any part missing or damaged, please contact HeimVision support.

PRODUCT OVERVIEW

NVR

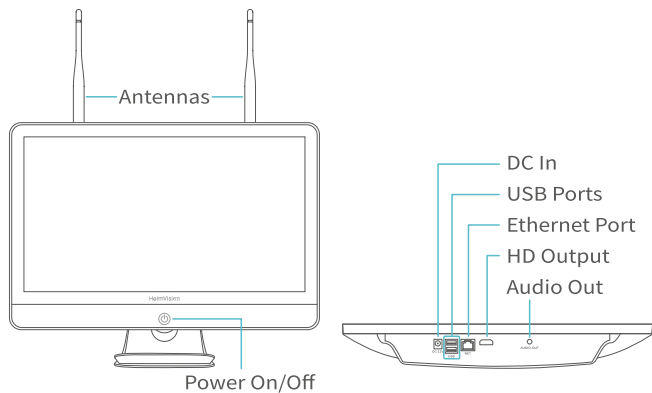

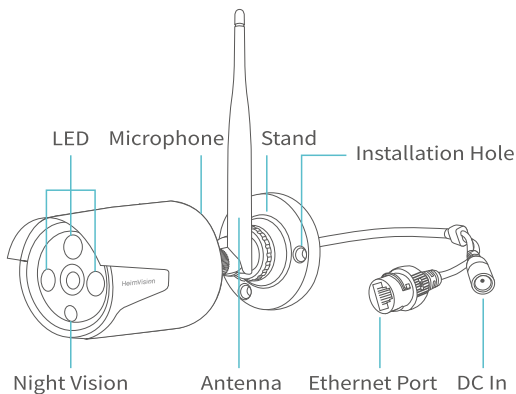

IP Camera



INSTALLATIONS AND CONNECTIONS

HDD Installation (Optional)

- ! **Notice:**
- 1 To record videos and play the recorded video, the installation of the HDD is a must. Otherwise, you can only watch the live picture.
- 2 Please check if you purchased the NVR kit with an HDD or without an HDD. If with an HDD, you may refer to the steps below to replace your HDD; while if without an HDD, you can purchase one, then install it following the instructions below.
- 3 This NVR system works with a 3.5" SATA HDD. The HDD should be formatted if it's installed.

<p>Step 1: Loosen the screws on the back cover of the NVR, then remove the cover. Please keep the screws well.</p>	
<p>Step 2: Connect the power cables and data cables of NVR to the corresponding ports of your HDD.</p>	
<p>Step 3: Fasten the back cover and your HDD with 4 screws we provided. Then buckle and push the back cover to assemble it.</p>	

Step 4:

Fasten the back cover and the NVR with the original screws.



System Connections

- ⚠** Do not fix the IP Camera before you can view the image on the screen and confirm the ideal position to install it.
- 1** Unfold the **Antenna** of the NVR, then plug the **Ethernet Cable** into the **Ethernet Port** on the NVR and your router.

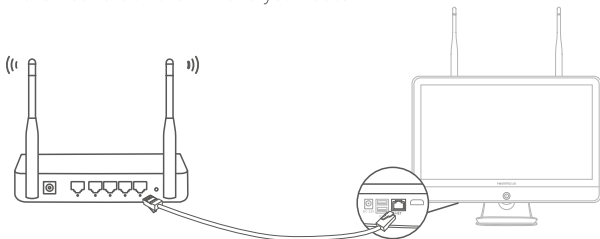

- 2** Install the **Antennas** for the IP cameras, then tighten them.

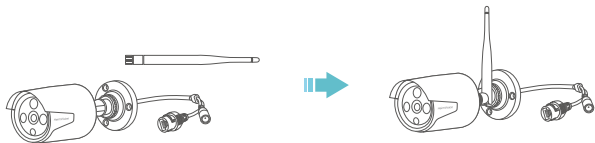

- 3 Plug the **Power Adapter(12V/3A)** into the NVR and a socket.

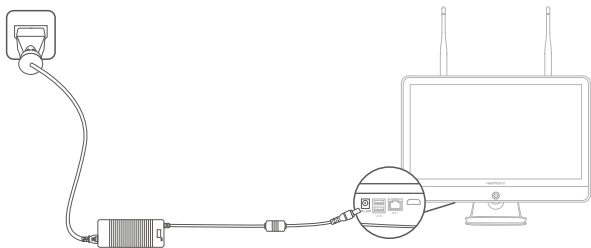

- 4 Plug the **Power Adapters (12V/1A)** into the IP Cameras and a socket.

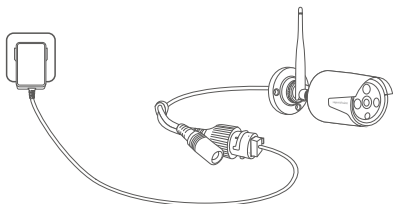

- 5 Connect the **USB Mouse** to one of the **USB Ports** on your NVR.

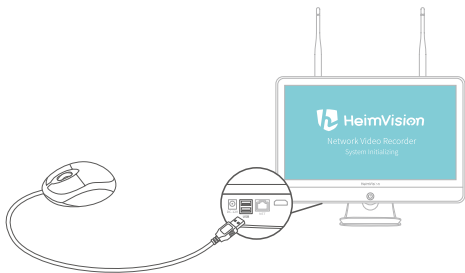

- 6 You can add more devices as required.

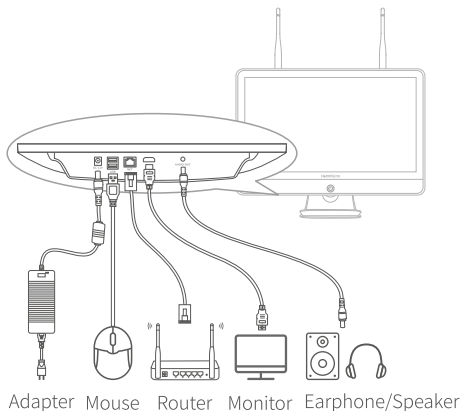

Camera Installation

Step 1:

Drill 3 holes on the wall/ceiling according to the holes on the camera base, then insert 3 green plastic expansion pipes into the holes.

Step 2:

Fix the base of the camera into the expansion pipes with 3 metal screws.

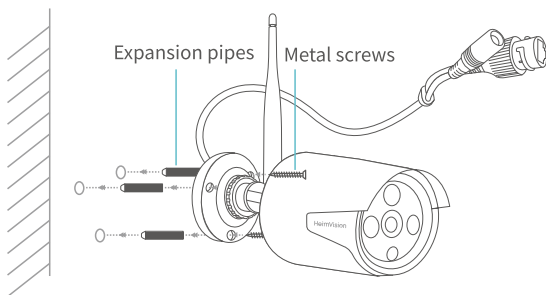

Step 3:

Loosen the screws on the camera to adjust the angle of the camera and tighten the screws after the adjustment.

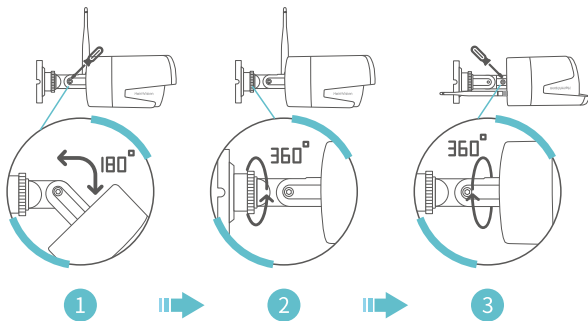

☀ Tips:

- ① For getting the best image, please don't point the camera towards a light source.
- ② Pointing the camera towards a window to see outside is not recommended, which may result in poor image due to glare, reflection and other reasons.
- ③ Clean the lens of the camera regularly.
- ④ The camera can be used outdoors but cannot be soaked in water. Please make sure the waterproof connector is used correctly and the port of DC In is protected from water.

OPERATE NVR SYSTEM ON A MONITOR

Live Picture

After connecting, wait for 2-3 minutes. The live pictures from the cameras will be displayed on the screen. Then you can start operating the NVR system.

! Notes:

- 1 The default **Username** for the NVR system is **admin** and the default **Password** is empty (no need to enter anything).
- 2 This NVR system can be only connected to the network by the Ethernet cable currently.
- 3 To protect your privacy, please go to **System setup > System Admin > User > Set password** to set the password at your earliest convenience.
- 4 Your password must be no more than 10 characters, otherwise there may be issues when you access the NVR remotely.

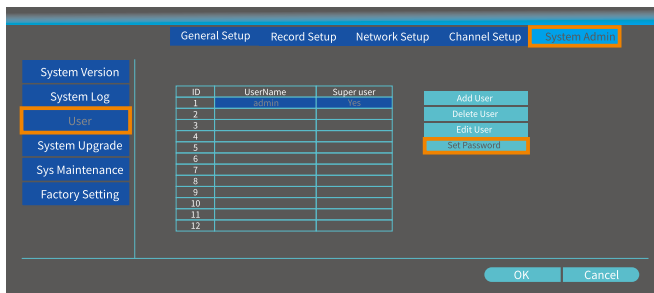

HDD Formatting

Right click on the main interface, go to **System Setup > General setup > HDD Setup** to check whether the HDD is formatted. If it's not, check the box to select the right HDD, then click **Format** and **Done**.

HDD Setup

Hard disk list

ID	Model	Capacity	Used	Status	Format
1	TOSHIBA DTO1ABA1	931 GB	8 GB	Formatted	<input checked="" type="checkbox"/>
2					
3					
4					
5					
6					
7					
8					

Format

Previous Done Cancel

Video Recording

Right click on the main interface, go to **System Setup > Record setup > Record Plan** to set the recording mode. The default recording mode of the NVR is 24/7 all time recording.

General Setup **Record Setup** Network Setup Channel Setup System Admin

Record Plan

Channel 1 Copy to Time Motion

	0	1	2	3	4	5	6	7	8	9	10	11	12	13	14	15	16	17	18	19	20	21	22	23
Su	Red	Red	Red	Red	Red	Red	Red	Red	Red	Red	Red	Red	Red	Red	Red	Red	Red	Red	Red	Red	Red	Red	Red	Red
Mo	Red	Red	Red	Red	Red	Red	Red	Red	Red	Red	Red	Red	Red	Red	Red	Red	Red	Red	Red	Red	Red	Red	Red	Red
Tu	Red	Red	Red	Red	Red	Red	Red	Red	Red	Red	Red	Red	Red	Red	Red	Red	Red	Red	Red	Red	Red	Red	Red	Red
We	Red	Red	Red	Red	Red	Red	Red	Red	Red	Red	Red	Red	Red	Red	Red	Red	Red	Red	Red	Red	Red	Red	Red	Red
Th	Red	Red	Red	Red	Red	Red	Red	Red	Red	Red	Red	Red	Red	Red	Red	Red	Red	Red	Red	Red	Red	Red	Red	Red
Fr	Red	Red	Red	Red	Red	Red	Red	Red	Red	Red	Red	Red	Red	Red	Red	Red	Red	Red	Red	Red	Red	Red	Red	Red
Sa	Red	Red	Red	Red	Red	Red	Red	Red	Red	Red	Red	Red	Red	Red	Red	Red	Red	Red	Red	Red	Red	Red	Red	Red

Select All Reset Apply OK Cancel

Tip:

You can click **Reset** to erase all the recording settings, then set the recording plan for each mode as needed.

Record videos according to schedules

After reset, select **Channel** and click  **Time** to start setting schedules. Left click and hold to select the day and hour you plan for recording. You can also click **Select All** to select all days and hours. The area selected will turn **Red** and click **Apply** to save the setting. The system will start recording at a specific time on a daily/weekly schedule.

Record videos when motion detected

After reset, select **Channel** and click  **Motion** to start setting recording schedules for motion detection. Left click and hold to select the day and hour you plan for recording. You can also click **Select All** to select all days and hours. The area selected will turn **Green** and click **Apply** to save the setting. The system will start recording when the camera detects any motion within the set time periods.

Note:

Changing the setting from 24/7 all time recording to scheduled recording or recording when motion detected helps to prolong the storage time of your HDD.

Video Playback

Right click on the main interface, then select **Video Playback** to play the videos recorded. The videos recorded from 4 channels can be played at the same time. Select the **Date** in **Green**, **Channel** and **Recording Mode** (Ⓒ), then click **Search** to list all the filtered videos.

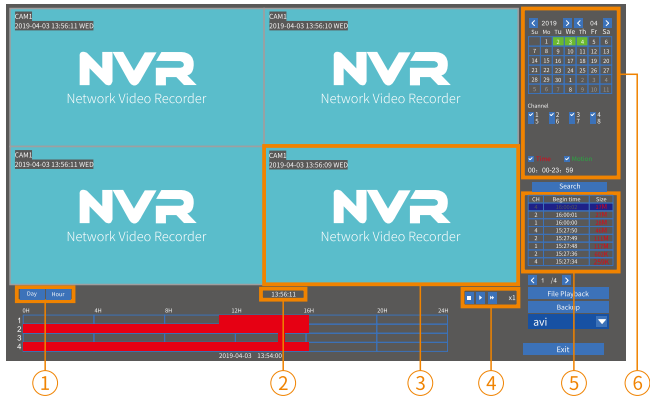

- ① Display the timeline by Day/Hour
- ② Video Recording Time
- ③ Area for Video Playing
- ④ Pause/Play/Fast Forward
- ⑤ Filtered Videos List
- ⑥ Filters

Option 1: Select one video file from the **Filtered Videos List** (⑤), then click **Play** or **File Playback** to play the selected video.

Option 2: Left click on the Red/Green (Red for **sheduled recording** and Green for **recording when motion detected**) part of the timeline.

Alarm Setting

Right click on the main interface, then go to **System Setup > Channel Setup > Video detection** to set alarms for channels.

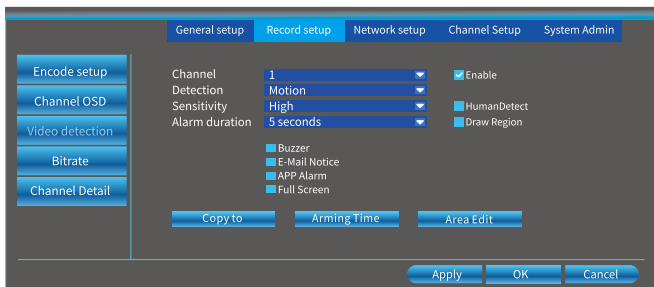

Channel:

Select a channel from 1 to 8.

Detection:

Select the alarm(s) for the channel(s).

【 Motion 】: This option is enabled by default and will be triggered when motion detected.

! Note:

Enabling this option is necessary for **Motion Recording**.

【 Video loss 】: This option will be triggered when the camera gets lost or disconnected.

【 Video cover 】: The area you select will become black without image to protect your privacy.

Sensitivity:

Set the sensitivity for the **Motion detection**, which ranges from 0 to 100 and the default setting is 50.

Human Detect and Draw Region:

These two options are disabled by default. If you enable them, the alarm of **Motion Detection** will be triggered only when the camera detects the movements of human, and the human outline will be marked with yellow border on the **Live Picture**.

Alarm duration:

Set the duration for **Buzzer**.

Buzzer:

Check the box, and the camera will buzzer when the selected option of **Detection** is triggered.

E-Mail Notice:

Check the box, and the NVR will send the messages to your email when the selected option of **Detection** is triggered. Please go to **Network Setup > E-Mail** to enable and set your email. Details refer to Q12 on Page 39.

App Alarm:

Check the box, and the App will push notifications to your mobile device when **Motion Detection** is triggered.

Full Screen:

The screen of the channel that issued the alarm will automatically turn into full screen.

Arming Time:

Set the time period for **Motion** and **Video loss**. The default setting is 24/7 all day monitoring and you can modify the time period. Click **Reset**, then select the time period you prefer.

Area edit:

Set the area for **Motion** and **Video cover**. The default setting is **all selected**. If you'd like to customize the detection area, please right click on the screen to bring up options of **all selected**, **all clear** and **return**. Select **all clear**, then left click and hold to start setting an area for detection.

! Note:

A  icon will be displayed on the live picture when any selected option of **Detection** is triggered. Click it to check the detailed alarm information.

Audio In and Out

There is a microphone on each camera which can pick up the sound around. Move the mouse to the live picture of each channel, you can see a  icon.



When there is sound around the camera, you can hear it from the NVR by connecting an earphone or external speaker to the **Audio Out** port on the NVR. However, you can only hear from one camera per time. Talking to the people near the camera via the NVR is not available as well.

Tips:

- 1 Click the  icon to turn on or off the sound that you can hear from the camera.
- 2 Videos will be recorded with sound all the time.

Video Backup

Right click on the main interface, then select **Video Backup** to enter the interface below.

The screenshot shows the 'Video backup' interface. At the top, there are search filters: 'Channel' (dropdown), 'Record mode' (checkboxes for All, 1-8), 'Search time' (date and time range), and 'USB:' (dropdown). Below these are 'Search' and 'Format' buttons. A table lists video files with columns for ID, Channel, Mode, Begin time, End time, Duration, Size, and Select. The 'Select' column contains checkboxes, all of which are checked. At the bottom, there are navigation arrows, a page indicator '1 / 4', a 'USB storage' dropdown, an 'AVI' dropdown, a 'Backup' button, and a 'Cancel' button.

ID	Channel	Mode	Begin time	End time	Duration	Size	Select
1	4	Time	16:00:02	16:10:13	00:10:11	19M	<input checked="" type="checkbox"/>
2	5	Time	16:00:01	16:10:13	00:10:12	100M	<input checked="" type="checkbox"/>
3	2	Time	16:00:01	16:10:13	00:10:12	30M	<input checked="" type="checkbox"/>
4	1	Time	16:00:00	16:10:13	00:10:13	30M	<input checked="" type="checkbox"/>
5	5	Time	15:33:50	16:00:01	00:26:11	275M	<input checked="" type="checkbox"/>
6	4	Time	15:27:50	16:00:02	00:32:12	46M	<input checked="" type="checkbox"/>
7	2	Time	15:27:49	16:00:01	00:32:12	111M	<input checked="" type="checkbox"/>
8	1	Time	15:27:48	16:00:00	00:32:12	117M	<input checked="" type="checkbox"/>

Step 1:

Select **Channel**, **Record mode** and **Search Time**, then click **Search** to display the filtered videos list.

Step 2:

Check the boxes to select the video files, click **Backup** and wait for a pop-up window to prompt you to insert a USB Drive within one minute.

Step 3:

Insert your USB Drive within one minute, then the NVR will back up the selected videos into your USB Drive automatically.

! Notes:

- 1 The NVR only supports the USB Drive up to 64GB and the format of the USB Drive should be FAT32.
- 2 To back up the video one by one via another method, go to the interface of **Video Playback** and select one video file from the filtered videos list. Click **Backup** and insert the USB Drive into the USB port of the NVR within one minute. The video will be saved to the USB Drive automatically.

Network Setup

Connecting the NVR to a router with the ethernet cable is a must if you want to remotely view the videos from a mobile device or a PC. You can check **Cloud ID**, **IP address** and **Web port** here.

- 1 The number under the QR code is the CLOUD ID of the NVR.
- 2 Make sure the Network status is **Healthy Network**.
- 3 Web port may vary on different NVR systems.

The screenshot shows the 'Network setup' configuration page. The 'DHCP' checkbox is checked. The IP address is 192.168.1.6, Subnet mask is 255.255.255.0, Gateway is 192.168.1.1, MAC address is 9GA3-A9D4-FE96, Preferred DNS is 192.168.32.1, and Web port is 80. The Network Status is 'Network Cable Disconnect'. A QR code and Cloud ID (2795880687) are also visible.

Setting	Value
IP address	192.168.1.6
Subnet mask	255.255.255.0
Gateway	192.168.1.1
MAC address	9GA3-A9D4-FE96
Preferred DNS	192.168.32.1
Web port	80
MTU	1400
Network Bandwidth	100 MB/s
Network Status	Network Cable Disconnect

Cloud ID
2795880687

Functions on the Menu Bar

Right click to show the main Menu Bar as below, right click again to hide it.

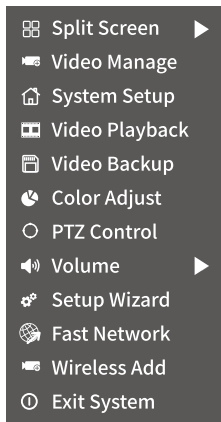

Split Screen:

To change the number of the channels showing on the same screen.

Video Manage:

To add IP cameras by **Match Code**, to manage IP cameras and channels, etc.

System Setup:

It includes General setup, Record setup, Network setup, Channel setup and System Admin.

* **General setup:** change Language, set up the Time, Change Display Resolution and check HDD information, etc.

* **Record setup:** to set up the recording mode for each channel.

* **Network setup:** to check the IP address, Cloud ID, etc.

* **Channel setup:** to change the name of the camera, check the Bitrate, etc.

* **System Admin:** to check the system version, update the system, set up password, make a factory reset and check the system log, etc.

Video Playback:

To playback the videos recorded.

Video Backup:

To back up the selected historical videos.

Color Adjust:

To adjust the picture's **Brightness, Contrast, Sharpness** and **Ircut mode**, etc.

Ircut mode:

Select from **daylight, night** and **Infrared mode** (default). **Smart mode** and **full color mode** are not available for this NVR.

【 daylight 】: The image from the camera is in color mode.

【 night 】: The image from the camera is in black&white mode.

【 Infrared mode 】: The image from the camera automatically toggles between. color and black&white mode according to the ambient light.



PTZ Control:

This NVR does not support the function.



Volume:

To adjust the volume when connecting an earphone or external speaker via the **Audio Out** port on the NVR.



Setup Wizard:

To show the QR code for app downloading and to show the Cloud ID.



Fast Network:

To configure the network.



Exit System:

To log out, reboot and shut down the system, etc.

OPERATE NVR FROM ESEECLOUD ON PC

Client Installation and Login



IMPORTANT:



<https://www.heimvision.com/download/Cameras> is the link for downloading **EseeCloud** or you can contact our HeimVision service team to get the installation link.



Your **Cloud ID** can be found in **Network Setup** (see on page 17).



Please make sure that your NVR is connected to internet, and the status of your network is **Healthy Network**.

Step 1:

Double click **EseeCloud_Setup.exe** to install the software and then run it.



Tip:

If you are prompted for missing files during the installation, please contact us to obtain the files needed to run this software.

Step 2:

Log in to EseeCloud Client with the default User Name (admin) and password (empty, namely enter nothing).

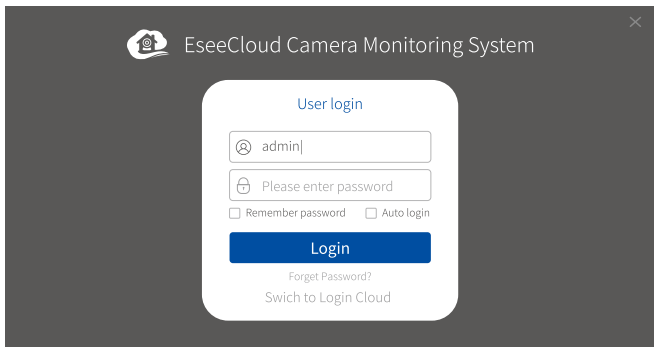

Step 3:

Click **+** Add on the upper right corner to add your NVR.

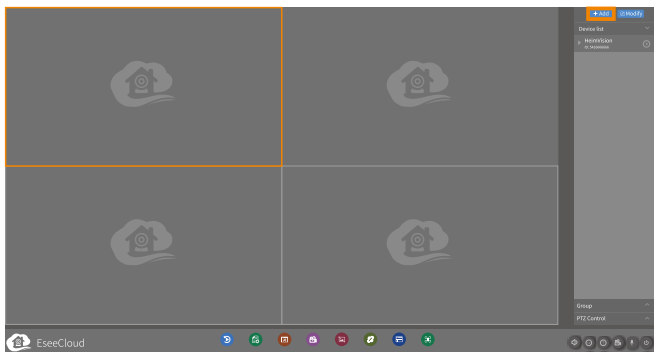

Step 4:

- Select **Cloud ID** on the left;
- Input your **Cloud ID**, **User name** (admin) and **Password** (skip it if you didn't set one);
- Select **NVR** in the box of **Type** and input **4** in the box of **Number of Channels**;
- Click **Finish**, and the NVR added will be shown under **Device list**.

EseeCloud

Add Device

IP/DNNS

Cloud ID

* Cloud ID: 541666666 Port: 10000

User Name: admin Password:

Area: center Device Name: HeimVision

Type: NVR * Number Of Channels: 4

Channel Serial: 1 Channel Name: ch_1

Channel Type: Normal Panorama: Close

Finish Cancel

Step 5:

Click  to connect your NVR and show the live pictures of all channels.

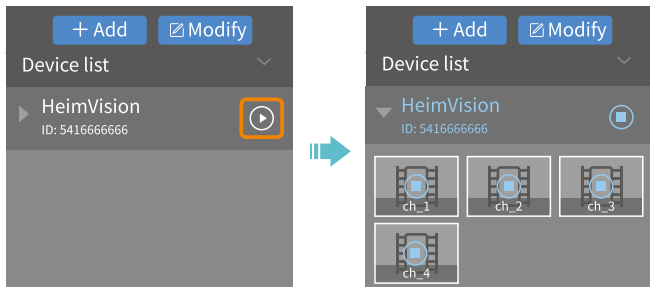

Tip:

The **Device list** is displayed in **Graphic** structure. If it's displayed in **Tree** structure, please double click on the device name to connect the system.

Video Playback and Backup

Click  on the bottom menu bar, then click **Confirm** in the pop-up window to enter the interface of Video Playback.



Step 1:

Click the device name to show the channels, then select **Channel**, **Record type** and **Date** to filter the videos, click **Retrieval** to display the recorded videos. You can click on the colored timeline to see the recorded videos by time.

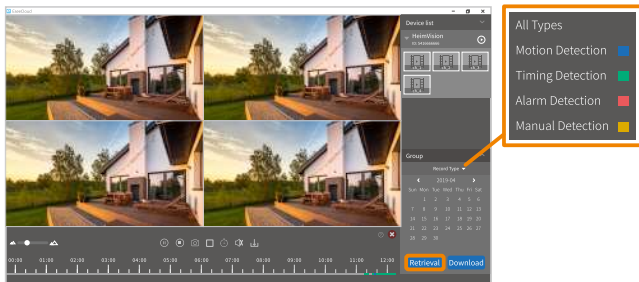

Tip:

Select a screen and double click to enter the full-screen mode; double click again to exist the full-screen mode.

Step 2:

Click **Download** on the lower right corner to enter the interface of **Download Resources**.

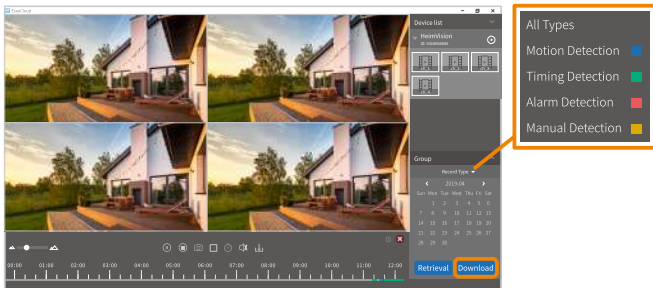

Step 3:

Click  to download the video one by one or click **Batch Download** to download all the videos together to your computer.

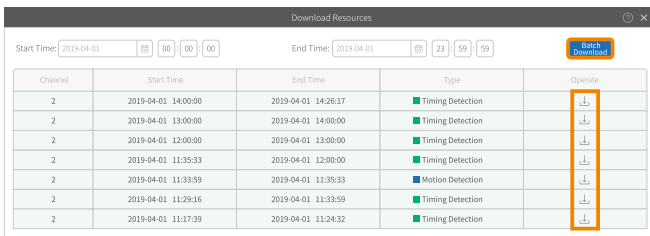

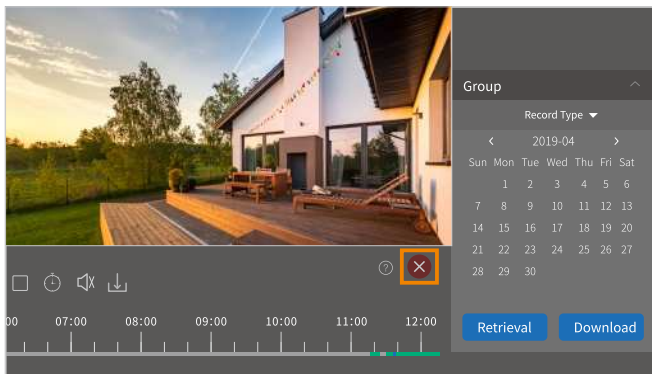

Step 4:

Click  to exit the video playback interface and get back to the live video interface.



Other Functions of the Bottom Menu

Device Management (): To add/delete NVR devices; to modify the device information.

User Parameter (): To select language; to change the storage paths of Screenshots and videos; to set time zone.

Record (): To record the live videos on your computer.

Screenshot (): To capture a screenshot of the live videos and save it on your computer.

Disconnect all (): To disconnect the NVR device.

Screen Number (): To change the number of channels showing in the screen.

More Function (): To change the password; to check the user logs; to check system messages.

OPERATE THE NVR ON A MOBILE DEVICE

i IMPORTANT:

- 1 Your **Cloud ID** can be found in **Network Setup** (see on page 17).
- 2 Please make sure that your NVR is connected to internet, and the status of your network is **Healthy Network**.
- 3 Please make sure the NVR and the mobile device are connected to the same network for the first time. Otherwise you can only manually add the NVR.

App Installation

Search and download **HeimKits** to your mobile device from **App Store/Google Play** or scan the QR codes below to download.



iOS System:
iOS 8.0 or later



Android System:
Android 4.4 or later

! Note:

Google Play™ is a trademark of Google Inc., and App Store™ is a trademark of App Inc.

Connecting the NVR system

Install and launch **HeimKits** App, then follow the steps below to add the NVR.

Step 1:

Register an account with your email address and log in to **HeimKits**, then tap **+** in the center or on the upper right corner to continue.

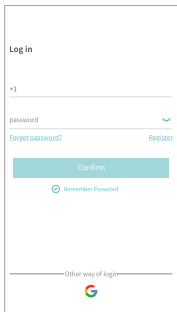

1

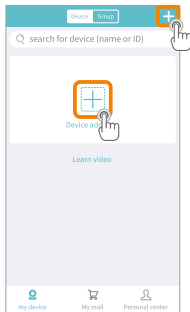

2

Step 2:

Tap Kit, then the App will search the NVR automatically.

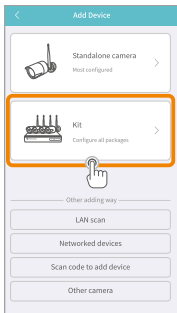

3

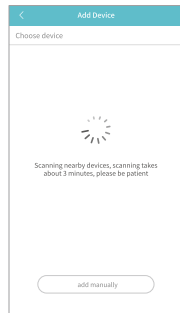

4

 Tip:

If the NVR is not added automatically, please tap **add manually** to add it.

Step 3:

Tap the NVR you added, then input the information required (e.g. enter the password if you set one) and tap **Complete** to enter the main interface.

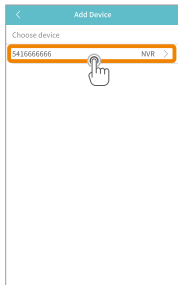

5

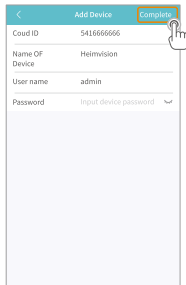

6

Step 4:

Tap the thumbnail on the main interface to show the live pictures.

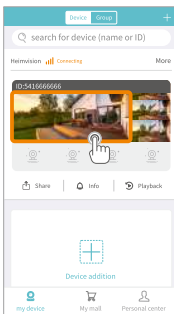

7

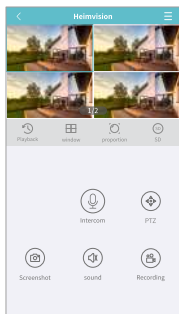

8



Playback:

Tap to view the videos recorded.



Window:

Change the number of channels displayed on the screen.



Proportion:

Change the aspect ratio.





SD:

Switch the image quality between SD and HD. SD is the default setting and recommended for smooth streaming.



Intercom:

Tap to start talking with people near the NVR. Press and hold the  icon to talk; press the  icon to hang up.

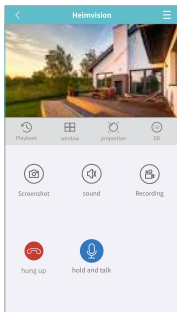

PTZ:

Unavailable.



Screenshot:

Tap to capture a screenshot to the App. Please go to the **Main interface** > **Personal center** > **Screenshot/Recording** to check.



Sound:

Turn on/off the sound from the camera.



Recording:

Tap to start recording the live video; tap again to end and save it into the App.

OPERATE NVR SYSTEM FROM A BROWSER ON PC

i IMPORTANT:

- 1 Your Cloud ID, IP address and Web Port can be found in Network Setup (see on page 17).
- 2 Please make sure that your NVR is connected to internet, and the status of your network is **Healthy Network**.
- 3 Internet Explorer (IE) browser is recommended.

Option 1:

When your PC is connected to the same Router as the NVR's, you can visit the local network to operate. Input your **IP address** (e.g. 192.168.32.213) into the search bar of your browser and log in to the NVR. Please install **Web View Control** after your first login, then change the Internet setting to allow the installation of **Web View Control**.

You can watch live videos, play and download the recorded videos and change the settings, etc.

Network video client



Username:

Password:

Remember me

Tip:

If the Web port (e.g. 80) of your NVR has been changed to another number, e.g. 1111, please enter 192.168.32.213:1111 into the IE browser.

Option 2:

When your PC is connected to a different Router which is not the same as your NVR's, you can visit the NVR through **Cloud**. Please visit www.e-seenet.com, install **Web View Control** as well, then input your **Cloud ID** (e.g.5416666666) and **Username** to log in to the NVR.

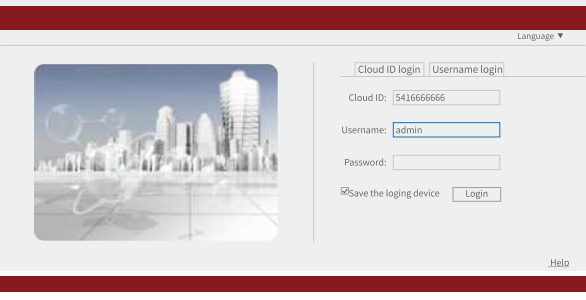

The screenshot shows a web-based login interface for an NVR. On the left is a square image of a modern city skyline with a prominent skyscraper. On the right is a login form with a dark red header bar at the top containing a 'Language' dropdown menu. Below the header are two tabs: 'Cloud ID login' (selected) and 'Username login'. The form contains the following fields and controls:

- Cloud ID:** A text input field containing the value '5416666666'.
- Username:** A text input field containing the value 'admin'.
- Password:** An empty password input field.
- Save the logging device:** A checked checkbox.
- Login:** A button to submit the login information.
- Help:** A small link at the bottom right of the form area.

EXTEND THE WIFI RANGE

The Wifi signal will be weaker when going through walls, stairs and other obstacles. However, there are some solutions that may help to extend the Wifi range.

Adjust the Antennas to the Appropriate Angle

According to the signal transmission character of antenna, it's better to adjust the antennas of the cameras to be paralleled with the antennas of the NVR when they are in a horizontal plane, or adjust the antennas of the cameras to be vertical to the antennas of the NVR when they are in a vertical plane. By doing so, your NVR can pick up better signals.

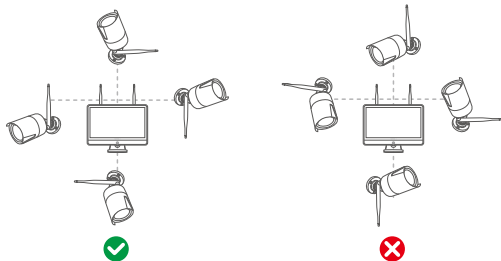

Tip:

Please keep your NVR away from the devices that interfere the connection easily, such as microwave oven, TV, etc. Make sure there are as few obstacles as possible between your NVR and the cameras.

Get an Extra Antenna Extension Cable with Stand

Take off the antenna of the IP camera, then install the Antenna Extension Cord into the IP Camera and put it in a position where the Wifi signal is strong.

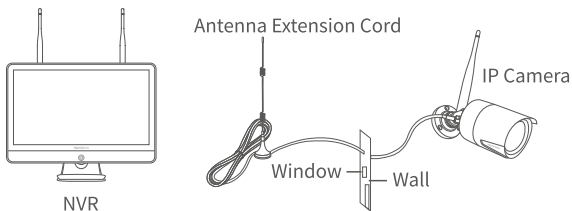

Get an Extra Repeater

To extend the Wifi range, you can also install a Repeater. Please refer to the user manual of the repeater if you bought one.

Setup Cascading Connection

Notes:

1. You can use the IP cameras as repeaters to extend the connection range.
2. This virtual **Repeater** function cannot strengthen the Wifi signal, but just help to extend the Wifi range by the IP Camera.

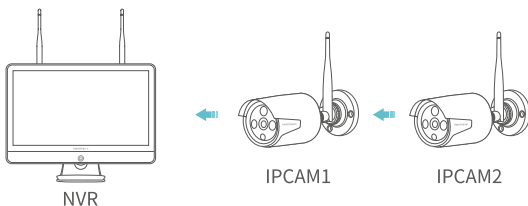

Step 1:

Right click the mouse to show the **Menu bar**, then click **Video Manage > Repeater** to enter the **Repeater** setting .

Video Manage

Protocol **N1**

ID	Device Name	IP Address	Port	Protocol

< 0 / 0 >

Channel	Device Name	IP Address	Status
1	IPCAM	172. 20. 14. 31	Connect Success
2	IPCAM	172. 20. 14. 32	Connect Success
3	IPCAM	172. 20. 14. 30	Connect Success
4	IPCAM	172. 20. 14. 33	Connect Success
5			
6			
7			
8			

Search
Match Code
Add One
Modify IP
Advanced

Delete
Delete All
Manual Edit
Channel Setup
Wireless Setup
Repeater

Ok Cancel

Step 2:

Click **+** after CH1/IPCAM1, then select **2** to set IPCAM1 as a repeater. This means CH2/IPCAM2 is connected to the NVR through CH1/IPCAM1.

Repeater

NVR

CH1 + 2

CH2 +

CH3 +

CH4

Connect Information

Channel	Signal
CH1	84
CH2	43
CH3	90
CH4	89
	--
	--
	--
	--

Refresh Apply Ok Cancel

Step 3:

Click **Apply** to finish the cascading connection. To check if it's set successfully, please click **Refresh**. To delete the **Repeater**, left click on the selected channel, then click **Apply** and **OK**.

ADD OR DELETE CAMERAS

This NVR system supports up to 8 cameras at most, please contact our HeimVision service team to get the purchase link. If you want to add/delete cameras, please follow the steps below:

Add Cameras

Step 1:

Plug the power adapter into the new camera and socket;

Step 2:

Plug the Ethernet cable into the NVR system and the camera;

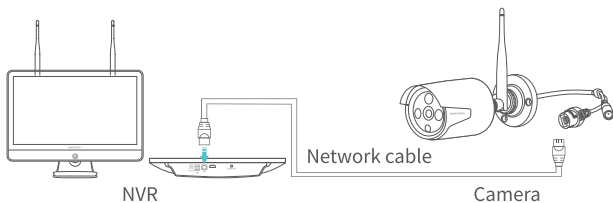

Step 3:

Right click the mouse to show the **Menu bar**, then select **Video Manage**.

Step 4:

Click **Search** to show the new IP camera and select it, then click **Match Code** to add the new camera automatically.

Video Manage

Protocol **N1** ▼

ID	Device Name	IP Address	Port	Protocol
1	IPCAM	172.20.14.33	80	N1

< 0 / 0 >

Channel	Device Name	IP Address	Status
1	IPCAM	172.20.14.31	Connect Success
2	IPCAM	172.20.14.32	Connect Success
3	IPCAM	172.20.14.30	Connect Success
4			No Sideo Source
5			No Sideo Source
6			No Sideo Source
7			No Sideo Source
8			No Sideo Source

Search

Match Code

Add One

Modify IP

Advanced

Delete

Delete All

Manual Edit

Channel Setup

Wireless Setup

Repeater

Ok Cancel

Delete Cameras

Select the camera need to be deleted from the added device list and click Delete.

Video Manage

Protocol **N1**

ID	Device Name	IP Address	Preview	Protocol

< 0 / 0 >

Channel	Device Name	IP Address	Status
▲ 1	IPCAM	172.20.14.31	Connect Success
2	IPCAM	172.20.14.32	Connect Success
3	IPCAM	172.20.14.30	Connect Success
▼ 4	IPCAM	172.20.14.33	Connect Success
5			No Video Source
6			No Video Source
7			No Video Source
8			No Video Source

Search
Match Code
Add One
Modify IP
Advanced

Delete
Delete All
Manual Edit
Channel Setup
Wireless Setup
Repeater

Ok Cancel

TROUBLESHOOTING GUIDE

Q1. There is no live picture sometimes.

- It may be caused by the poor network due to Wifi interference, obstacle blocking and so on.
 - 1 When you are viewing the live picture from the Cloud, please make sure the network connection between the NVR and router works well. At the same time, make sure the router provides enough upload bandwidth. To improve the quality of network, you can reboot the router regularly.
 - 2 When you are viewing the live picture from the same network as your router's, please make sure the network connection between the camera and NVR works well. You can check the quality of the Wifi signal from the live interface.
 - * If the Wifi signal is good but the live picture of all the channels still buffers and lags, another device may interfere the connection between the NVR and cameras. Please try to get rid of it or change the Wifi channel from **System Setup > Network Setup > Wireless Setup > Wireless Channel**.
 - * If the Wifi signal of one channel is poor, move the camera close to the NVR to check whether the strength of Wifi signal is stronger and make sure the antenna of the camera is fixed well and pointed at the right direction. If the Wifi signal of all channels is poor, please slowly move the antennas of the NVR until they point at the right direction as mentioned in the section of **Adjust the antennas to the appropriate angle** on page 30.

If you need more help, please feel free to contact us at support@heimvision.com.

Q2. There is no live picture when using a browser to log in to the NVR.

- Please go to **System Setup > Network Setup > Web port** to check whether the **Web port** has been changed from **80** to another number, e.g. **1111**. If yes, input the **IP address** and **:1111** into IE to visit. For example, the IP address is **192.168.251.106** and the **Web port** is **1111**, then please input **http://192.168.251.106:1111**.

- Make sure you have installed the **Web View Control** correctly on your IE browser.

Q3. Can I add an extra new camera?

- The camera with the same brand is recommended when you'd like to add more cameras. To get the link of buying camera and the detailed guide for adding the camera, please contact us at support@heimvision.com.

Q4. What should I do if I remove a camera from the NVR system?

- The steps to add it again are the same as adding a new camera mentioned in the section of **Add Cameras** on page 33. Find the camera that matches with the deleted channel, connect it to the NVR with the Ethernet cable, then go to **Video Manage > Match Code** to add it.

Q5. How long is the storage time of the Hard Disk Drive?

- The example below is for an average data rate 2Mbps and 4 cameras. The capacity of storing the video for one day (24 hours) is around 84.38GB based on the formula below:

$$2 \text{ (Mbps)} * 3600 \text{ (secondsperhour)} * 24 \text{ (hoursperday)} * 4 \text{ (Channels)} = 691200 \text{ Mb}$$

$$691200 \text{ Mb} = 86400 \text{ MB}$$

$$86400 \text{ MB} = 84.38 \text{ GB}$$

If you have a 1TB Hard Disk Drive, the capacity of it after formatting is around 921GB.

The storage time is around 11 days (921GB/84.38GB \approx 11).

However, the data rate of the camera is **Variable Bitrate** which depends on the surveillance environment. If there are many moving objects in the live picture, the data rate will be faster. Go to **System setup > Channel setup** to check it, then use the formula mentioned above to calculate it.

Q6. NVR system cannot detect the Hard Disk Drive.

- Make sure the NVR works well.
- Make sure the power cable and SATA cable of the Hard Disk Drive are connected correctly and firmly.
- Try another Hard Disk Drive.
- The Hard Disk is a consumable. The Hard Disk Drive with brand and for 24/7 surveillance is recommended. Make sure you back up the important videos timely for safety.

Q7. What should I do if I forget the password for logging in to the NVR?

- Please send us the time (e.g. 2019-03-20 23:59:57 WED) displayed on the live picture of the channel. The server will generate a temporary password which is only valid for 15 minutes. Heimvision support team will send you the password.

Q8. How can I set up to automatically turn off the screen?

- Please go to **System Setup > General Setup** to enable **Auto turn off screen**. The screen will be off if there is no any operation on the NVR within 10 minutes.

Q9. How can I receive the push notifications for App?

- Right click on the main interface, then go to **System Setup > Channel Setup > Video detection**, check **APP Alarm** and click **Apply**, then your mobile device will receive notifications when the camera detection is triggered.
 - * Please make sure you have allowed **HeimKits** to send push notifications to your mobile device.
 - * Please make sure you have enabled the option of **Settings > Alarm message push** on the App.

Q10. What should I do when the PC shows the device online but the App shows offline?

- * Please check whether you have entered the correct Cloud ID on KeimKits App.
- * Make sure the network of your mobile device is stable and strong.
- * If the issue persists, please send the screenshot of the reported error to HeimVision support team to check for the solution.

Q11. How far can the cameras work from the NVR?

- It depends on the Wifi signal strength and interference attenuation. It's recommended to place the cameras within the range of 65ft-98ft away from the NVR.

Q12. How can I receive notifications in my Email?

- Right click on the main interface, then go to **System setup > Network setup > E-Mail** to set it following the instructions below:
 - 1 **E-Mail function:** check the box to enable it.
 - 2 **SMTP Provider:** select from gmail, hot-mail and Yahoo mail, etc. according to your email service provider.
 - 3 **Sender:** enter your email address.
 - 4 **Password:** enter the correct password of your email address.
 - 5 Click **Test** to check whether you can receive the test email. If yes, the setting is successful; if not, please check the box before **More Parameter** to continue the following steps.
 - 6 **Port:** enter the corresponding port of your email service provider. You can refer to the following list.

Email	SMTP server	Port	Encryption
Gmail	smtp.gmail.com	465	✓
Hot-mail	smtp.live.com	587	✓
Yahoo mail	smtp.mail.yahoo.com	465	✓

7 **Encryption Type:** select SSL or TLS.

Tip: You can obtain the **Port** and **Encryption Type** from your email service provider. Or contact us for help.

8 **Sendee 1:** it's the same as the **Sender** by default. You can change to another email address to receive the notifications, then click **Apply** to complete the setting.

9 Click **Test** again to check if you can receive the test email.

Explanations of other options:

* **Sendee 2:** it is not necessary to fill in. But you can enter another email address to receive notifications when your family member wants to know as well.

* **Subject:** you can change as needed or just leave it like this.

* **Interval:** set the time interval to receive the alarm message. The default setting is 30 seconds. Please avoid setting the time interval too short, as it may cause the insufficient space of your email.

* **Health email enable:** check the box to enable it, then you will receive emails that tell you the NVR works normally.

* **Health email interval:** set the time interval of email for telling you that the NVR works well.

SPECIFICATIONS

Operation frequency	2412-2472MHz
Max. RF output power	< 12 dBm

FCC STATEMENT

This device complies with Part 15 of the FCC Rules. Operation is subject to the following two conditions:

- (1) This device may not cause harmful interference, and
- (2) this device must accept any interference received, including interference that may cause undesired operation.

NOTE:

This equipment has been tested and found to comply with the limits for a Class B digital device, pursuant to Part 15 of the FCC Rules.

These limits are designed to provide reasonable protection against harmful interference in a residential installation. This equipment generates uses and can radiate radio frequency energy and, if not installed and used in accordance with the instructions, may cause harmful interference to radio communications. However, there is no guarantee that interference will not occur in a particular installation. If this equipment does cause harmful interference to radio or television reception, which can be determined by turning the equipment off and on, the user is encouraged to try to correct the interference by one of the following measures:

- Reorient or relocate the receiving antenna.
- Increase the separation between the equipment and receiver.
- Connect the equipment into an outlet on a circuit different from that to which the receiver is connected.
- Consult the dealer or an experienced radio/TV technician for help.

WARNING:

Any changes or modifications not expressly approved by the party responsible for compliance could void the user's authority to operate this equipment.

This equipment should be installed and operated with minimum distance 20cm between the radiator& your body.

IC STATEMENT

This device complies with RSS247 of Industry Canada. Cet appareil se conforme à RSS247 de Canada d'Industrie. This device complies with Industry Canada license-exempt RSS standard(s). Operation is subject to the following two conditions:

- (1) this device may not cause interference, and
- (2) this device must accept any interference, including interference that may cause undesired operation of the device. appareils radio exempts de licence. Son fonctionnement est sujet aux deux conditions suivantes:
 - ① le dispositif ne doit pas produire de brouillage préjudiciable, et
 - ② ce dispositif doit accepter tout brouillage reçu, y compris un brouillage susceptible de provoquer un fonctionnement indésirable.

This equipment complies with RF radiation exposure limits set forth for an uncontrolled environment. This transmitter must not be co - located or operating in conjunction with any other antenna or transmitter. This equipment should be installed and operated with minimum distance 20cm between the radiator& your body.

Ce matériel est conforme aux limites d'exposition aux rayonnements rf énoncées dans un autre environnement.cet émetteur ne doit pas être situées ou opérant conjointement avec toute autre antenne ou l'émetteur. Ce matériel devrait être installé et adapté à une distance minimale de 20cm entre le radiateur et votre corps.

CAUTION

RISK OF EXPLOSION IF BATTERY IS REPLACED BY AN INCORRECT TYPE.
DISPOSE OF USED BATTERIES ACCORDING TO THE INSTRUCTIONS

 The symbol indicates DC voltage



RECYCLING

This product bears the selective sorting symbol for Waste electrical and electronic equipment (WEEE). This means that this product must be handled pursuant to European directive 2012/19/EU in order to be recycled or dismantled to minimize its impact on the environment.

This product can be used across EU member states.



CUSTOMER SUPPORT

North America support@heimvision.com

United Kingdom support.uk@heimvision.com



[@HeimVisionOfficial](https://www.facebook.com/HeimVisionOfficial)



[@heimvision_official](https://www.instagram.com/heimvision_official)



www.heimvision.com