

Circuit Diagram

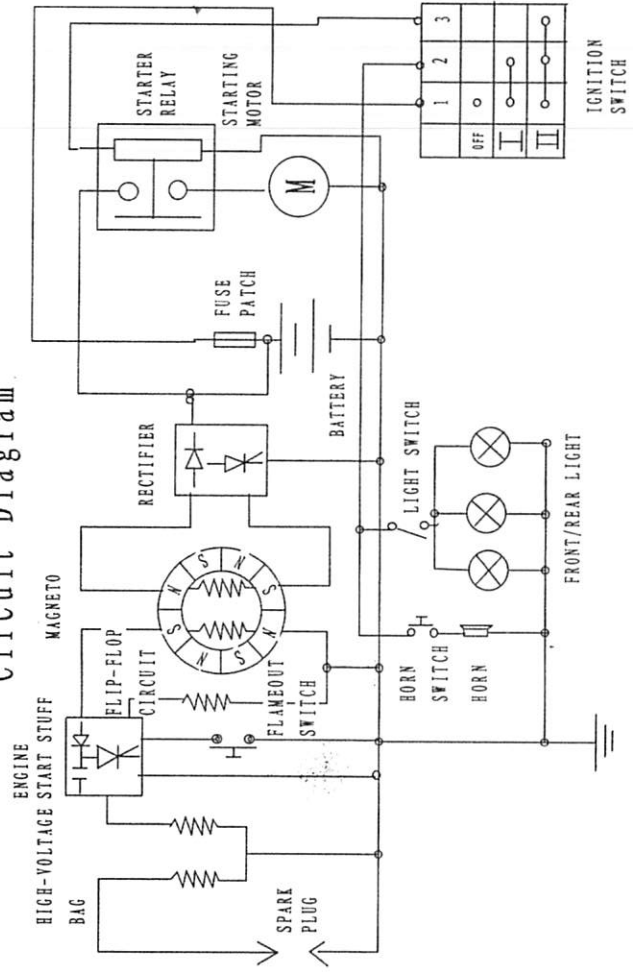

110/125GKG-2 Series Off-road Kart USER'S MANUAL

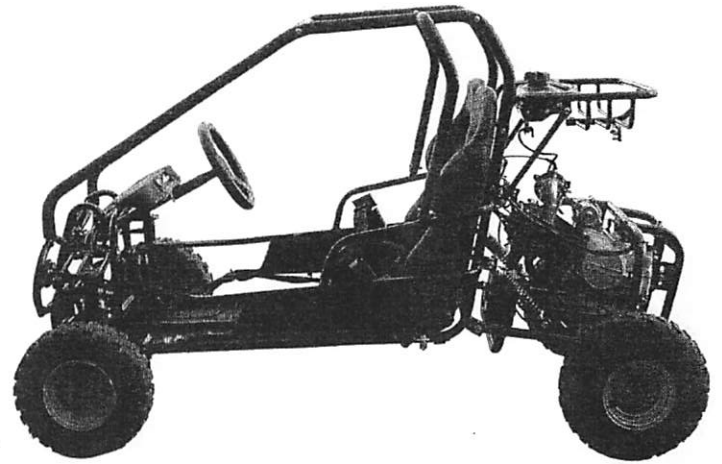

Important safety warning

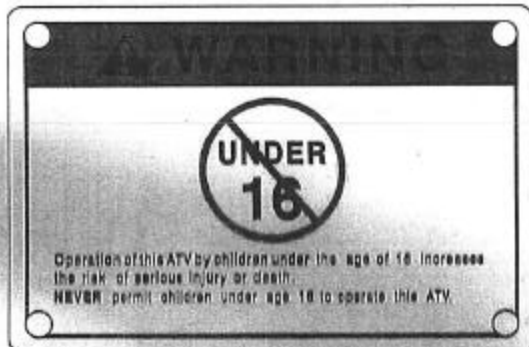

SERIES OFF-ROAD KART USER'S MANUAL

Dear Sir or Madam,

Thank you very much for your choice of this Off-road Kart.

The Off-road Kart is manufactured according to the full survey of market demand. We hope that it will bring you driving pleasure.

Please read the manual carefully before driving because it will help you learn the basic knowledge of structure, function, operation and maintenance of the Kart, which will be of great help for you to keep it in good condition and drive more safely.

The materials and pictures provided in the Manual is the latest information made according to the newest products. There possibly are differences between the contents in the manual and the actual situation of Kart as a result of the improvement or changes of the products. But the user has to operate by the real,

situation. The producer preserves the rights revision of the Manual at any time, with no further information or notice.

No one can copy, quote or print any part of the Manual without permission from the producer.

Please contact the dealers if you have any problems about the kart's operation and maintenance.

▲ **Warning:** Drivers and Parents should read and follow the rules in Section 4 before driving Off-road Kart, which is about the important events and safety.

1105A

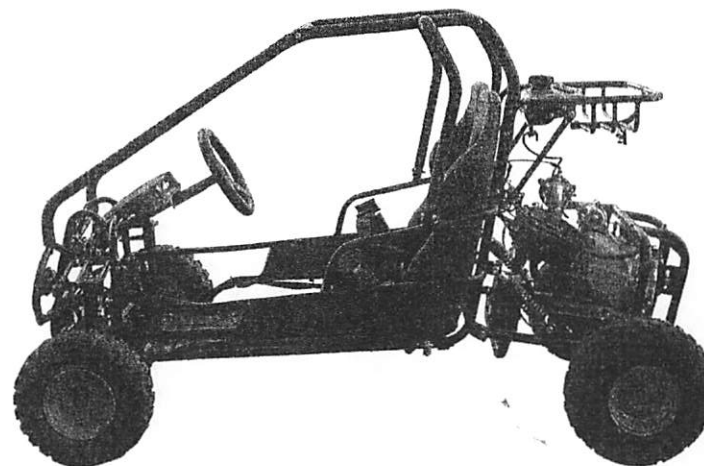

Contents

1. Brief Introduction to Off-road Kart
2. Main Technical Parameter Table
3. Vehicle Assemblage
4. Important Events and Safety
5. Components and Operation Introduction
6. How to Drive Off-road Kart Properly
7. Maintenance of Off-road Kart
8. Warranty Information
9. Schematic Diagram

1. Brief Introduction to Off-road Kart 1.1 Brief Introduction

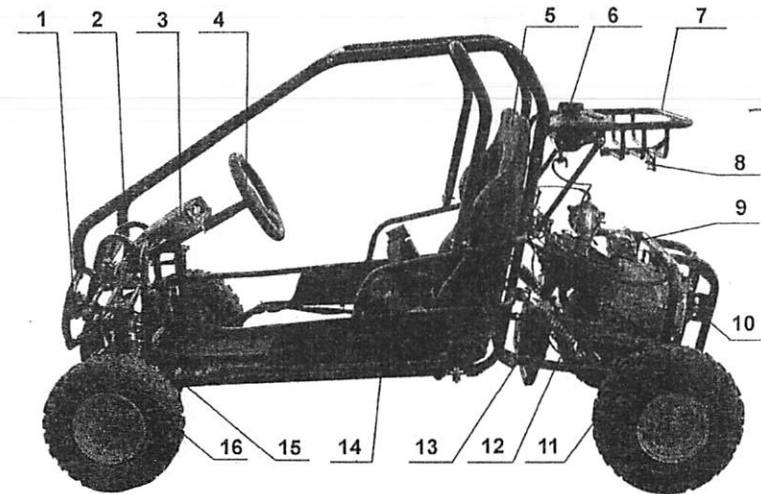

1. head light 2. Main guard pole 3. Control panel 4. Steer wheel and steer pole 5. Seat assembly 6. Gasoline tank 7. Basket 8. Brake light 9. Engine assembly 10. Rear frame 11. Rear tire assembly 12. Rear absorber 13. Battery 14. Safety belt assembly 15. Front absorber 16. Front wheel

◆ The shape of this Off-road Kart for leisure and entertainment is new and unique. The frame is welded with excellent steel pipe, which is high in structural

strength with reliable safety.

◆ Front independent suspension and articulated and complicated shock-absorber in the rear frame are adopted, which is comfortable and is of great help to prolong the life of the components of the whole vehicle.

◆ Front wheel and rear axle hydraulic disk arrester is adopted, which has a good effect and easy and soft operation.

◆ This type of karts has taken an engine with high efficiency and low oil consumption.

◆ The electrical system is simple and reliable as well, which is a leisure and entertainment vehicle based on good function.

◆ Single transmission / multi-gear shifting engine is adopted in the vehicle, better and convenient customer in energy usage.

1.2 Engine and Frame Identification Numbers

Engine Identification Number: Please remember Engine Identification Number for the check when necessary. The location of Engine Identification Number is under the output chain wheel of the engine.

Frame Identification Number: Frame Identification Number is the unique number for all the vehicles and please make a record for the check when necessary. It is on the framework under the seat.

2. Main Technical Parameter Table

110cc

Item		Parameters
External Dimension	L×W×H (mm)	1680×1100×1105
	Axle Base (mm)	1330
Weight	Dry Weight (Kg)	118
Passenger(s)	2	
Engine	Type	Single Cylinder, Four Strokes, Wind Cooling
	Exhaust (ml)	107
	Form of Transmission	L、N、R or 1、2、3、N、R
	Emission control (When need)	CO: 35g/km, HC+NO _x : 1.5g/km
Power	Highest Speed (km/h)	50
Tire	Type/Air Pressure Front	13×5.00-6 MAX:20 P.S.I
	Type/Air Pressure Rear	145/70-6 MAX:24P.S.I
Electrical System	Battery	12V 9Ah
	Safety Fuse	10A
Capacity	Oil tank(L)	2.0

125cc

Item		Parameters
External Dimension	L×W×H (mm)	1700×1100×1140
	Axle Base (mm)	1330
Weight	Dry Weight (Kg)	126
Passenger(s)	2	
Engine	Type	Single Cylinder, Four Strokes, Wind Cooling
	Exhaust (ml)	119.6
	Form of Transmission	L, N, R or 1, 2, 3, N, R
	Emission control (When need)	CO: 35g/km, HC+NO _x : 1.5g/km
Power	Highest Speed (km/h)	55
Tire	Type/Air Pressure Front	145/70-6 MAX:24 P.S.I
	Type/Air Pressure Rear	16×8-7 MAX:24P.S.I
Electrical System	Battery	12V 9Ah
	Safety Fuse	10A
Capacity	Oil tank(L)	2.0

3. Vehicle Assemblage

1. Take off the cover and fixing poles by using wrench.
2. Take out Steer Wheel and pan head cruciform slot screws or hexangular flange face screws and install Steer Wheel on the Steer Wheel fixing base (pay attention to the place of Steer Wheel, put the front turning wheels parallel to the rear wheels, let Steer Wheel with 3 strips up face the rear). Fasten the screw and put on the cover of Steer Wheel.
3. If it is equipped, put the protective plastic jacket into the pipe of goods shelf, put the screw bolt backings into the hexangular flange face screws and then fix the goods shelf with the backing screw.
4. If it is equipped, put the protective plastic jacket into the pipe of bodywork, put the screw bolt backings into the hexangular flange face screws and then fix the protective pipes with the backing screw.
5. Take the oil tank from the box and fix on the oil output mouth. Fix oil tank on the supporter by hexangular flange face screws. Put one end of non-burning rubber oil-input pipe into the oil-output mouth. Take off the dust-free cover on the mouth of the

carburetor, put the other end to the input oil mouth on the carburetor.

6. Take out the hexangular screws and hexangular flange face nuts and fix the seat.

7. Connect the wires by the plugs and screw nuts which on the poles of the battery to the corresponding place (attention: the positive wire connects to the positive pole of the battery, black wire connects to the negative pole of the battery). Tighten the screws.

8. Plug in the joints of all lights on proper position.

Check and make sure that every screw is tight and then you can prepare to use the kart.

4. Important Events and Safety

This Off-road Kart is more than a toy and it will cause danger if driving improperly. Please abide by the following suggestions strictly to avoid the injury.

- ◆ You mustn't drive at an excessive speed. You must control the speed properly according to the road situation, the field of vision, your driving experiences and your operating conditions.

- ◆ Keep a proper gap with the other vehicles to avoid collision.

- ◆ Please examine the off-road Kart before driving,

making sure that it is in the condition that safe driving can be obtained. You can inspect according to the process and maintenance specified in the Manual and the explanation attached to the components, making sure that all the joints are tightened and safe.

- ◆ Before starting the engine, you must make sure that the driver is on the seat and the vehicle is in the controllable state.

- ◆ You must drive with defined loading capacity, with no over-loading driving.

- ◆ Never carry a passenger on a single seat vehicle. A multi-seats vehicle can only carry defined number of person, don't pick up more. And never carry the persons who is too young to step on the footrest or unable to grip the armrest.

- ◆ The passenger can only sit on the passenger seat, never sit on other location and must grip the armrest tightly during driving.

- ◆ You must put your hands on Steer Wheel all the time when driving and make sure that the running direction is under your control.

- ◆ You must abide by the operating procedures and methods when turning the vehicle.

- ◆ You must practice the low-speed turning before you conduct the high-speed operation. Please don't turn

at an excessive speed.

- ◆ You must do warming-up exercises before driving the vehicle.

Please read the Manual and all the warning notes carefully before driving and operate by following strictly the procedures and methods.

- ◆ Don't lend the kart to anybody that can't drive it.

- ◆ You mustn't drive the vehicle on the street, driveway or sidewalk.

- ◆ You mustn't drive off-road Kart under the influence of drink or anesthesia agents because this will badly reduce your judging ability and cause serious injury and even death.

- ◆ You must drive on the slippery and steep road after mastering the skills of driving for it is dangerous to do so. Attention: driving on the slippery, broken stone or soft road will prolong the braking distance.

- ◆ You must drive on the strange road slowly and carefully.

- ◆ You must learn how to drive off-road Kart in a proper way and a qualified training coach is a necessity. The driver must be more than 6 years old and of adequate understanding, intelligence and judging ability for controlling the driving safely.

- ◆ You must add petrol to the oil tank before you drive it for the first time. If it is four-stroke engine, you must add the engine oil in time according to the requirement of the engine. Attention: please don't add the fuel when the engine is in operation or it is hot. You must keep the source of heat and the flame away from the oil tank.

- ◆ You must adopt the tires of size and type defined in the Manual and keep the tire at the defined air pressure. The proper air pressure can ensure the reliable braking and turning.

- ◆ Please don't change the position and the state of the components or add any attachments at your will.

- ◆ You mustn't operate the engine in a closed environment because end gas from it will be dangerous to life.

- ◆ It is dangerous for any parts of body or clothes to touch the engine, noise deadener or any other revolving parts. Please keep away from them.

- ◆ You must follow the local suggestions and rules to drive the off-road Kart in helmet and protection clothes.

- ◆ You must fasten the seat belt when driving, with no hand, foot or head exposing outside of the vehicle.

- ◆ You must follow the rules and the regulations of

the sports ground or the local authorities when driving for pleasure.

◆ Please don't drive the vehicle if your body dimension or health status are not suitable.

◆ Please keep the vehicle far away from the resource of heat and fire if you store it for a short time. Please empty the petrol in the oil tank if you store it for a long time. Please store the Manual properly for the necessary usage.

◆ Certain experiences are required to repair and maintenance the vehicle and all the actions of its kind must be done under the safe conditions.

5. Components and Operation Introduction

5.1 Location of Components

See Picture 1.1

5.2 Operation of Components

☆ **Steer Wheel**

Steer Wheel is used to control the direction of the off-road kart, the kart will turn right or left according to the corresponding operation.

▲ **Warning:** You must keep the hands on Steer Wheel to avoid t

he losing control of the kart when driving the off-road kart. Otherwise it may cause serious accidents even death.

☆ **Braking Pedal**

Braking Pedal is operated by left foot. It will work when step hard forward and the off-road kart will slow down.

▲ **Warning:** You must be skillful in the operation and the force Braking Pedal and Gas Pedal when driving initially Off-road Kart so that you can control the speed properly especially in the curves and among the karts.

☆ **Gas Pedal**

Gas Pedal is operated by right foot. It will accelerate when step hard forward and slow down otherwise.

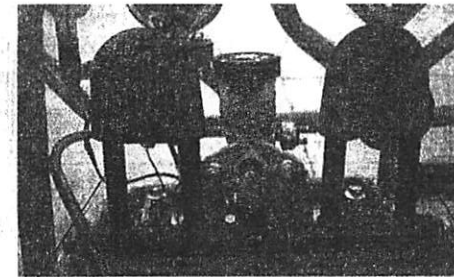

Braking pedal

accelerating pedal

☆ **Gear-engaging Device**

Backward and slower Gear

Forward and faster Gear

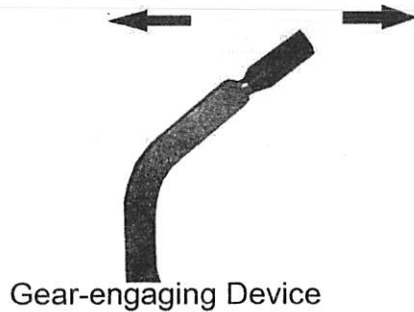

If there is gear-engaging device in your kart, you must make clear the function and operating ways of each gear so that you can avoid the danger arising from the unexpected running.

The back gear device is on the left of the seat.
The gear-operating ways for the engine are as follows:

When the engine on the neutral, there will be no output drive, then move the handle forward once, the vehicle can run faster. It is same principle on backwardness.

▲ **Warning:**

Attention: You must stop when change reversed gear.

☆ **Control Panel**

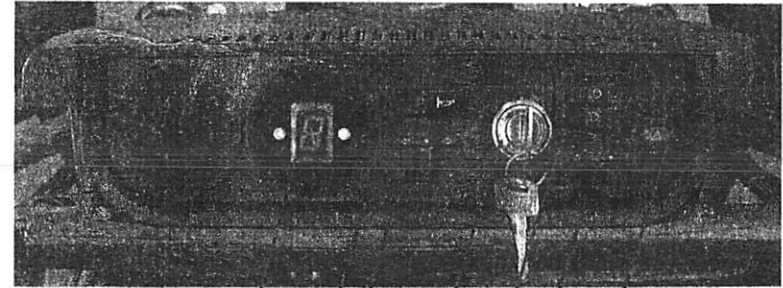

Shifts Displayer

Horn Switch

Turning Signal Switch

Ignition Key

Beam Switch

Hazard Lamp Switch

Light Switch

☆ **Ignition Key**

Turn the Ignition Key clockwise to the first gear and Braking Indicator will be on.

Engine-start: Electric Start (Ignition Key is on Control Panel), you can start the engine by turning Ignition Key clockwise to the second gear.

☆ **Hazard Warning Lamp Switch**

If the vehicle is in trouble you may press down this switch to warn others.

☆ **Horn Switch**

The horn will be switched on if pressed and off if loosened.

☆ **Seat**

You can adjust the location of Seat by moving the hand lever under the cushion. You can move the hand

lever right and then move to the place necessary and loosen the hand lever. Attention: please resume the



Seat Adjuster (back and forth)

location of the hand lever.

☆ Oil Tank (Cover)

There is a blowhole on Oil Tank Cover, which should not be blocked.

Please add the petrol no more than the neck bottom of oil feeding mouth when adding.

You must fasten Oil Tank Cover after finishing adding petrol.

☆ Hand Brake

The hand brake of kart is located at the front of the gear handle. The Kart will be braked if you pull backward the hand brake when stopped and will be loosened if you put down the brake.

6. How to Drive Off-road Kart Properly

▲ Special Attention:

1. The petrol in the oil tank and the engine oil in the engine have been emptied for the safe transportation. Before starting, please add petrol and engine oil to the defined place.

2. If the kart has gear system and you must put the gear into neutral till the indicator is on (the gear indicator is in front of the frame) before starting the engine and then run the kart with the necessary gear.

6.1 Preparations before Driving

Such preparations are necessary as receiving the proper training and guidance, checking your off-road kart and making sure that it is in good condition and learning the rules of driving safely. You must put on the protecting equipment, such as helmet and long-sleeve clothes.

6.2 Vehicle Check before Driving

It is necessary for you to spend few minutes on checking your off-road kart before driving so that you can save time and keep safe in the long-way driving. This include the following items:

a. Adding of engine oil

If you use it for the first time, you must add petrol and engine oil in it. The petrol number is 93 or above.

You must add oil to the engine in time according to

the using requirement and the engine oil number is: SF 15W/40SF. 0.8L(Summer);SF10W/30SF.0.8L(Winter).

▲ Warning:

Attention: Please don't add petrol or engine oil when the engine is running and keep the oil tank away from the heat resources and flame.

b. Quantity of Petrol

You must add petrol in time if the quantity of petrol is not adequate so that it will not break down on the way. You should check the leakage of Oil Tank.

c. Brake

Please check the operation of the brake and adjust the free path when necessary.

d. Tires

You should check the tightness of the screw bolt and screw nut, the state and the air pressure of the tires to see if it is suitable to drive.

e. Accelerator

Please check the accelerator if it can move freely and if it can resume its position.

f. Ignition Key and Blanket Switch

Please check the joints and plugs if they are tight and work properly.

g. Screw Bolt, Screw Nut, Fastener

Please check the wheel axles to see if the screw bolts are tight and to see if the other screw bolts and screw nuts are tight and reliable. You must make sure that the screw

bolts of Steer Wheel is tight and reliable and the front wheels turn in the same direction of Steer Wheel freely.

h. The Lower Part of Vehicle and Exhaust System

Please check and clear the dust, plants and the other foreign substances that will possibly cause fire or wrong operation.

You must clear all the faults before driving and you can also ask help from the dealer of franchiser if you fail to do so.

▲ Warning: It will increase the possibility of the accidents if you don't check the vehicle and clear the faults before driving. You should check it according to the procedures and maintenance in the Manual and make sure that the vehicle is in good and safe condition.

6.3 Steps of Start the Engine

☆ Put the vehicle on the flat place.

☆ Put Ignition Key to the location of starting the engine, with no more than 8 seconds every time.

Please press slightly Gas Pedal and repeat the above-mentioned steps if you fail to start it for several times.

6.4 Running-in

The new vehicle must experience the running-in period before normal use. The running-in period is during the first 350km traveling distance.

Please don't run at a too fast speed or even tread Gas Pedal to the bottom in the first few weeks driving the new vehicle. The right way to run in the engine will be of great help for the life and performance. It will be better to run in the engine at a various revolving speed.

6.5 Driving

You should choose a safe and flat place without any obstacles and vehicles to conduct the initial driving.

After starting the engine and allowing running for a moment for warming-up, you can drive by grasping Steer Wheel, seeing the front ways and treading Gas Pedal gradually.

6.6 Turning

You should control the speed properly when turning and it will be difficult to run in the expected direction and track if you run at an excessive speed.

You should use Gas Pedal and Braking Pedal properly to ensure the security when turning. And you should lurch to the turning direction.

▲ Attention: You should practice the turning at a low speed firstly and increase the speed gradually to get familiar with the operating features of the off-road Kart.

6.7 Stop

It will be better for you to choose a flat place to park the vehicle.

When parking, you should loosen Gas Pedal and tread Braking Pedal, reducing the speed until it stops.

7. Maintenance of Off-road Kart

7.1 Routine Maintenance

The following is the routine maintenance table. It is made according to the general situation and you must conduct the maintenance more frequently if the driving environment is worse and dust is more.

Routine Maintenance Table

Notes: I-Inspection, clean, adjust and lubricate or replace when necessary, C-Clean, R-Replace, L-Lubricate

Item	Maintenance in 1 st Week	Monthly Maintenance	Annual Maintenance
Petrol Pipe Line System*	I	I	
Accelerator*	I	I	
Air Filter		C	I
Sparkling Plug		I	
Engine Idle Speed	I	I	
Drive Chains	I, L	I, L	
Braking Disk Fretting Quantisty		I	I
Braking System*	I	I	
Screw Bolt, Screw Nut, Fastener	I	I	
Tires	I	I	

Turning System			I
Front Suspension System	I		I
Engine Oil*	I	I	R

▲ Warning: You should cut off the engine when conducting maintenance and otherwise it will possibly damage the moving and hot parts.

▲ Warning:

1. When conducting maintenance, please read the operation guidance and warning signs and prepare the necessary tools and auxiliary materials.

2. The clean, flat, ventilating and bright place should be chosen to conduct the maintenance. The engine should be stopped unless necessary. Please choose the real products if it is necessary to change the components.

3. Please ask help from dealers of the producer if you can not conduct the maintenance by yourself.

4. It will be better for you to ask the dealers of the producer to repair or maintenance the items with “**”, unless you have enough tools, maintenance parameters and experiences.

7.2 Spark Plug

- ☆ Take off the cap of Spark Plug.
- ☆ Dust the tray of Spark Plug.
- ☆ Take out Spark Plug by wrench.
- ☆ Inspect the electrode and replace it if the electrode and the nonconductor are burnt in a improper way.
 - ☆ A new one should be installed if Spark Plug is apparently burnt or the nonconductor is broken.
 - ☆ Inspect the distance between the electrodes. You must maké it to the right place carefully if the distance is not proper.
 - ☆ Please drive the screw by hand if installing Spark Plug to avoid sliding-filament.
 - ☆ After the above-mentioned step, you can drive fasten it 1/2 circle (for new Spark Plug) or 1/4 – 1/8 circle (for used Spark Plug) by the special wrench for Sparkling Plug.

▲ Attention: You should tighten Spark Plug and otherwise it will cause the damage of engine as a result of overheating.

7.3 Air Cleaner

Routine cleaning is necessary because dust will be left in Air Cleaner during the use. Frequent cleaning should be conducted if driving in the dusty area.

7.3.1 Cleaning of Air Cleaner

- ☆ Take off the plastic protecting jacket.
- ☆ Take off the cover of Air Cleaner.
- ☆ Take the filter out of the of Air Cleaner.
- ☆ You can clean the cleaner in the dissolvent of inflammable and high flash point. Then soak the filter in the clean engine oil for 5 minutes and squeeze out the rest engine oil.

▲ **Attention:** You should not tighten it to squeeze out the rest engine oil and the otherwise will damage the filter.

- ☆ Dust the empty Air Filter Box, the cover and the entrance and place the dry filter into Air Filter Box.

7.4 Brake Staff

Disk Brake is adopted in the vehicle and you should inspect the free path of Brake Pedal, the joints of the braking system and the leakage.

Routine inspection is necessary for the braking disks to make sure that it doesn't reach the extreme points.

- ☆ Free Path of Brake Pedal

The distance between the initial position of the pedal and working position means Free Path of Brake Pedal.

- ☆ It is necessary for you to replace the braking disk if it is less than 3 mm thick.

- ☆ Please replace the braking pedal if it is not active. Please pay attention to spring, screw bolt, linchpin and the pipe when replacing.

7.5 Accelerator

- ☆ The Free Path of Accelerator is 3–5 mm, which can be measured from the initial position to the position where the revolution begins to rise.

- ☆ It is necessary to adjust Accelerator Cable and the screw nut in the end of Carburetor if Free Path of Accelerator is not in its proper distance. You should lock it after adjustment.

- ☆ Please replace Accelerator Cable if it is damaged.
- ☆ Inspect the return spring of Accelerator Pole and replace if it can not work properly.

7.6 Tire Check

- ☆ The over-high or over-low Air Pressure benefits nothing to the proper performance. The measure of Air Pressure should be conducted under the cool state.

- ☆ Depth of Tire Checker
Please check surface and side and make sure that there is no crack on it, no foreign substances in it and no leakage of air. You should replace the tire if the depth of tire checker is less than 2 mm.

7.7 Battery

☆ You must connect the red wire to "+" pole and the black wire to "-" pole when installing the battery. You should replace the battery if it cannot store electricity. Generally speaking, battery should be replaced every 2-3 years.

☆ Safety Wire

Safety Fuse must be installed in the safety wire box.

If safety wire is frequently damaged, there is possibly a short circuit or over-loading.

The change of Safety Wire:

- a. Open safety wire box and take out the safety wire plate.
- b. Insert the new safety wire plate into safety wire box.
- c. Resume the cover of safety wire box.

7.8 Carburetor

The idle speed adjusting screw bolt on Carburetor is used to adjust the speed of idle speed. Tighten the screw and the speed will slow down; loosen the screw and the speed will speed up. You must adjust the speed to the lowest stable position when adjusting.

The rest inspections of Carburetor need certain experiences and please contact the dealers of franchiser for technicians' help.

7.9 Steering System

Routine screw inspections for the Steering Pole, Steering Machine and Turning Pole are necessary.

Toe-in: You adjust them by pulling Pole and the distance is 2-4 mm.

8. Warranty Information

See Warranty (Service and Repair) Manual that contains warranty information.