

# **OWNER' S MANUAL**

**ModelCovered:BD150T-2 BD150T-3**

**BD150T-5 BD150T-6**

**BD150T-8 BD150T-9**

**Boom International Holdings (USA), Inc.**

## FOREWORD

Congratulations on your purchase of our product . Your new motorcycle is the product of advanced engineering, exhaustive testing, and continuous striving for superior reliability, safety and performance.

Please read this Owner' s Manual carefully before riding so that you will be thoroughly familiar with the proper operation of your motorcycle' s controls, Its features, capabilities, and limitations. This manual offers many safe riding tips, but its purpose is not to provide instruction in all the techniques and skills required to ride a motorcycle safely. We strongly recommends that all operators of this vehicle enroll in a motorcycle safely. We strongly recommends that all operators of this vehicle enroll in a motorcycle rider training program to attain awareness of the mental and physical requirements necessary for safe motorcycle operation.

To ensure a long, trouble-free life for your motorcycle, give is the proper care and maintenance described in this manual. Please pay special attention to the part of run-in operation.

This manual should be considered a permanent part of the motorcycle and should remain with the motorcycle when it is sold.

All products are subject to change without prior notice or obligation.



BD150T-2



BD150T-3



BD150T-5



BD150T-6



BD150T-8



BD150T-9

---

---

## CONTENTS

1. **Safety notices**
  - Dressing
  - How to ride
  - Loading
2. **Description**
3. **Number Location**
4. **Control Functions**
  - Meters
  - Ignition switch
  - Electric starter switch
  - Engine stop switch
  - Dimmer switch
  - Horn switch
  - Turning light switch
  - Storage compartment
  - Handlebar locking
  - Tool compartment
  - How to start the engine
5. **Operation**
  - Ridding off
  - Correct ridding
  - How to park
6. **Inspection before ridding**
  - Check fuel
  - Check engine oil
  - Check brakes
  - Check tires
  - Check lights
  - Check handlebar
  - Check speedometer and horn
  - Check front and rear shock absorbers
  - Check rear view mirror and license plate
  - Other checks
7. **Run-in Operation**
8. **Periodical Maintenance**
  - Periodical maintenance chart
  - Maintenance and replace battery
  - Replace fuse
  - Check spark plug
  - Replace gear oil
  - idle speed adjustment

General lubrication

9. **Trouble shooting**
10. **Specifications**
11. **Wiring Diagram**

## 1. **safety notices**

### **Dressing**

Do not dress loosely to ride. Dress neatly and tidily with tight cuffs to avoid the brake levers. It is safe to put on low-heeled shoes.

Wear a helmet and tie it well.

### **How to ride**

While riding, keep natural posture, this will make you consciously operation .

The operation safety of the two-wheeled scooter is effected by the seating position. Please sit in the center of the seat. If sitting on the rear of the scat, it will reduce the load of the front wheel, and it is easy for the handlebar to swing and causing danger.

While turning, it is easy to turn with body inclining toward inside and the scooter is more stable.

Emergency brake and urgent turning are the causes of side sliding and side turning over. It is very dangerous, especially when riding on a wet road or at high speed. Be careful!

While riding on a poor road, reduce the speed, and loosen your hands, wrists shoulders, tightly grasp the throttle grip and keep stable riding.

While passing by a stopped vehicle, keep as possible from it and push the horn to warn others not to stop suddenly and start the motor, this can avoid an accident.

It is very dangerous to ride on slipping road in rainy days. Be careful! Don' t ride fast and make an abrupt turn. Keep it in your mind that the distance of brake in rainy days is double of usual days.

While going down the slope, return the throttle grip to its position, and perform periodical brake, ride solely. Pay attention to the front and rear brakes not let them retain in semi-brake status for long, otherwise the brake shoe will be burned, the life of the shoe will be shortened.

While starting to brake, pull the throttle grip back to its position at once, and grasp the front brake lever or step on the brake pedal. After the speed is reduced, squeeze or step on to the end. This is the most desirable braking means.

While starting brake, the rear and front brakes should be used at the same time, otherwise, it is easy to slide down.

**CAUTION**

Do not touch the exhaust pipe within 10 minutes after stopping the engine, for it is very hot.

Please park away from dry lawn or inflammable articles.

The brake shoe will be wet while cleaning the scooter. Check before riding.

**Loading**

The handlebar is difficult to handle after loading. Be careful! Operation of an overloaded scooter could easily cause the handlebar to swing.

Therefore, never overload your scooter. The loading weight on the carrier should not exceed 5 kg, on the tool compartment, 1 kg, and the storage compartment, 10 kg.

Securely fasten the goods on the carrier with strong ropes. The loose packing will influence the stability of the scooter and your attention to the road.

Put objects in the rear box and fasten it on the carrier if there is only one.

**CAUTION**

Operate according to the manual.

Observe traffic regulations and ride carefully.

**2. Description**

Rear view mirror

Helmet hold hook

Storage compartment



Fuel tank cap

Seat lock

Brake/tail light  
Air cleaner  
Kick lever  
Battery  
Side stand



Ignition switch  
Throttle grip  
Seat  
Rear turn signal light  
Muffler  
Center stand  
Front turning light

### 3. Number Location

Vehicle Identification Number (VIN) and engine serial number are not only used for registration, but also used as the warranty for maintenance.

The number location is shown as arrowhead A, B and C indicate:

**A, C indicates:**

Vehicle Identification Number (VIN):

**B indicates:**

Engine serial number:



#### 4. Control functions

##### Meters

##### 1. Speedometer

The speedometer registers miles per hour of forward speed.

##### 2. Odometer

The odometer registers the number of kilometers the vehicle had traveled. The unit of last is hundred meters.

##### 3. High beam indicator light

This indicator light comes on when the high beam is used.

##### 4. Turn indicator light

When the turning switch is used, the corresponding turn indicator light will turn on simultaneously.

##### 5. Fuel gauge

The gauge shows the fuel in the tank

(when the ignition switch is on "Ⓚ" position, the hand of the fuel gauge returns to zero.) When the hand is within the red area, it means there is still 1 liter of fuel in the tank. Please fill gasoline as earlier as possible.



##### Ignition switch

In this position, all circuits are switched off. The engine cannot start.

In this position, electrical circuits are switched on. The engine can start. The key cannot be removed.

In this position, the handlebar is locked. (See page 11.)



**CAUTION**

Always lock the handlebar and remove the key when the scooter is unattended.



**Electric starter switch**

To use the electric starter switch, turn the ignition switch to “ ”. Squeeze the brake lever or press down the brake pedal firmly. Push this switch, and the starter motor runs. The engine is started. ( For more information, please read page 13.)

**Engine stop switch**

Turn the ignition switch to “ ”

**RUN:** In this position, ignition circuits are switched on. The engine can start.

**OFF:** In this position, ignition circuits are switched off. The engine cannot start.

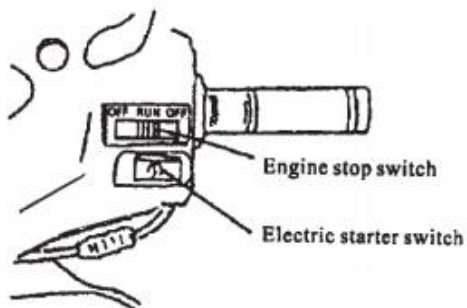

Engine stop switch

Electric starter switch

**Dimmer switch**

Turn the ignition switch to “ ”

The high beam light comes on

The low beam light comes on. When riding in urban or meeting with vehicles coming from the front, turn on this light to avoid affecting others' view.

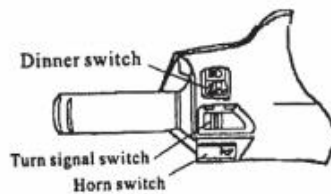

Dinner switch

Turning light switch

Horn switch

**Horn switch**

Turn on the ignition switch to “ ” . Press the born switch to sound the born.

**Turn signal switch**

While turning or changing the lane, use the turn signal switch. Push the switch left or right, the front or rear turn signal light and the turn signal indicator light will flash accordingly.

: Signal a left-hand turn.

: Signal a right-hand turn.

To stop the flashing light, turn on the switch .

**CAUTION**

The turning light cannot go off automatically. It should be turned off after using. Otherwise it will affect other driver' s safety.

When the ignition switch is at “ ” , the turning light will not operate.

**Storage compartment**

The storage compartment is located under the seat

**Storage compartment**



Storage compartment

**CAUTION**

The loading weight in the storage compartment should not exceed 10 kg.

Do not put objects or food that cannot stand for high temperature, or flammable material into the compartment, for the engine is very high at temperature.

Do not put precious articles into the compartment .

Do not let water enter the compartment while washing the scooter.

**Handlebar locking**

To prevent theft of your scooter, always lock handlebar when parking.

**How to lock**

Turn the handlebar all the way to the left. While pushing the key into the ignition switch, turn it from “ ” to “ ” and remove it. Thus, the handlebar is locked.

**How to open the lock**

To release the lock, turn the key to “ ”, and the handlebar can move.

**CAUTION**

After locking, turn the handlebar lightly to make sure it is locked.

Never turn the key to “ ” while the scooter is moving. This will result in loss of control or an accident.

Do not park the scooter on the place blocking traffic.

**Tool compartment****How to open**

To open the tool compartment, put the key into the hole and turn clockwise

**How to lock**

Turn clockwise after putting in the key, and close the cover. Turn counter clockwise to lock the tool compartment.

**CAUTION**

The loading weight in the tool compartment should not exceed 1.0 kg.

Do not put precious objects in the tool compartment.

Water may enter the tool compartment when washing the scooter. Take care of the inside objects.

**How to start the engine**

Before starting the engine, make sure the engine oil and fuel are enough.

To start the engine, retract toe center stand.

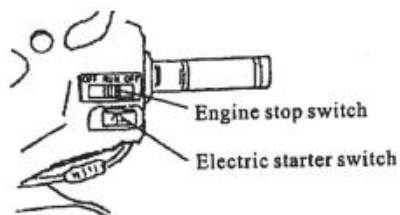

Engine stop switch

Electric starter switch

Turn the ignition switch to “ ”.  
Turn the engine stop switch to “RUN”



**CAUTION**

When the key turns to “ ”, the horn and turn signal lights can operate.

**Electric start**

Squeeze the brake lever or press down the brake pedal firmly. Push the electric starter switch to the engine.

**CAUTION**

Do not operate the electric starter continuously for more than 5 seconds. Wait at 10 seconds between each operation of the starter.

Release the electric starter switch at once after starting. Never operate the electric starter when the engine is running, or it will cause damage to the starter motor.

To operate the electric starter, squeeze the brake lever or press down the brake lever or press down the brake pedal firmly. Otherwise, the electrical circuits are off and the starter motor dose not work.

**Kick start**

Open the throttle a little bit and step on the starting lever fully. The engine will be started.

**CAUTION**

After starting the engine, release the kick lever for safety, or the engine can be damaged.

The exhaust fumes contain carbon monoxide that is harmful to human body. Never start your motor in a place ventilated poorly or closed area.

**5. Operation**

**Riding off**

Brake the rear brake pedal, then push the scooter forward, the central stand will rebound automatically.

Straddle the scooter from the left side with your left foot on the ground prevent

slipping down.

Open the throttle slowly while releasing the brake. The scooter will start to move.

**CAUTION**

Before riding, apply the rear brake to avoid rushing out.

Before don't open the throttle at will, to avoid the scooter rushing, causing, causing accident.

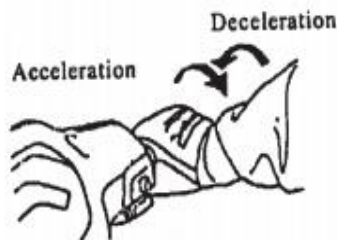

**acceleration**

Deceleration

**CAUTION**

Do not open the throttle greatly because the scooter will rush out abruptly.

**Correct riding**

Before riding, turn on the turning light. Make sure there is no vehicle coming from the back, then start to ride.

**CAUTION**

See page 1 to page3 for safety notice.

Strictly observe the break\_in requirements ( see page 24 ) for a new scooter and avoid riding at sudden acceleration.

After the run-in period, gradually increase the speed to its highest. Remember not riding at high speed for a long time, or it will cause danger and shorten the service life of the engine.

The speed adjustment is controlled by the throttle grip.

Increase the throttle      Accelerate

Open the throttle slowly

Opening the throttle gradually at the beginning or during climbing the hill.

Decrease the throttle      Decelerate.

**How to park**

**Near parking lot**

Turn on the turning light. Stop the scooter after making sure no vehicle is coming from the back.

warn the back vehicles.

**After firmly parking**

Turn off the turning light, and turn the ignition switch to



Get off the scooter from the lift, and push the scooter to a level surface where is not blocking the traffic.

Hold the handlebar with left hand, and the lower groove of the seat with right hand. Stop down the center stand with right foot. Put back with right hand forcefully, and the center stand will be up

**CAUTION**

Please park away from dry lawn or inflammable articles.  
Do not touch the exhaust pipe within 10 minutes after stopping the engine, for it is very hot.

**6. Inspection before riding**

**Check fuel**

Check the fuel gauge when the ignition switch is in “ ” position. When the needle is within in the red area, about 1.0 L fuel remains in the fuel tank, Please fill the fuel tank with #93 gasoline as possible.

Insert the key to open the seat and open the fuel tank cap by turning it 1/4 circle clockwise.

Turn counter clockwise to its original place to lock the cap, then lock the seat.



Oil tank cap  
Fuel tank cap  
Seat lock

**CAUTION**

Stop the engine when refiling. Avoid fuel dropping on the heating engine.  
 Turn slowly when opening the fuel tank cap.  
 The fuel tank capacity is about 7.8 liters.

**Check engine oil**

Place the scooter with the center stand up on a level surface. Remove the dipstick to wipe it clean, then put it into the engine oil inlet (don't need to turn it). Take out the dipstick. When the level nearly reach the lower limit, please add the engine oil until it reaches the upper limit. The oil tank capacity is about 0.9 liter.

Please use SF 10w/30 or SF 15w/40 four-stroke special 4-stroke oil.

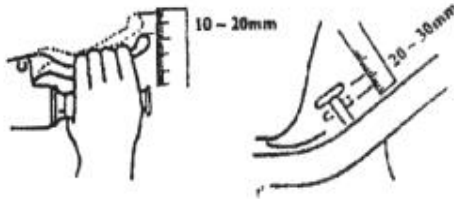

The engine oil dipstick

Upper limit

Lower limit

**CAUTION**

If the scooter is tilted or just stopping, it can lead to false readings on the meter.  
 After the engine is stopped, beware of being scalded if you check the oil lever or refuel at once.  
 Please use the specified 4-stroke engine oil. Do not mixed with other oil.

**Check brakes**

The brake lever or pedal should have an adequate free play ( as shown ).

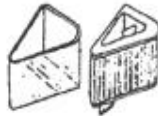

Squeeze the brake lever or press down the brake pedal firmly. A soft, spongy feeling in the brake lever indicates the adjusting nut should be adjusted. If the adjustment produces no effect, the brake system is faulty. Please go the repair station for maintenance.

**Check tires**

Check the pressure of the front and rear tires frequently because the improper pressure will cause abnormal tread wear and cracks, resulting in danger while riding.

	Standard tire pressure	Size of the tire
--	------------------------	------------------

Front wheel	280kpa	120/70-12
Rear wheel	280kpa	120/70-12

When the tread depth of front and rear tires are below 1.6 mm, replace the front and rear tires. The excessively worn tires will result in unstable handling, causing accidents because of loss of control.

When the tires have cracks and scratches, replace them with new ones.

#### **Check lights**

Turn on the ignition switch to “ ” position:

Turn on the turn signal switch. Check if the front and rear turn signal lights flash simultaneously.

Apply the front and rear brakes to check if the brake lights come on.

Turn the ignition switch to “ ” to check if the city lights, meter light, headlight, and license light come on, and if the dimmer switch operates normally.

#### **Check handlebar**

Shake the handlebar up and down, forward, left and right to check for slack.

Turn left and right to check for free movement and blocking case.

Put the front wheel straight forward to check the handlebar for deflection.

#### **Check speedometer and horn**

Turn on the ignition switch to “ ” position:

Push the horn switch to check if the horn sounds and if the sound is normal.

Ride at low speed to check if the needle of the meters turns normally.

#### **Check front and rear shock absorbers**

Press the handlebar and the seat, then bounce up and down to check the front and rear shock absorbers for good operation.

#### **Check rear view mirror and license plate**

Sit astride the seat to check if the angle of the rear view mirror is proper.

Check the license plate for damage or slack.

#### **Other checks**

Check if the muffler is loose, and the sound is normal.

Check if the previous abnormal cases still exist.

### **7. run-in operation**

The first 1500km that the motorcycle is designated as the run-in period. If the motorcycle is not used carefully during this period, you may very well end up with a “broken down” instead of a “broken in” motorcycle after a few thousand kilometers.

The following rules should be observed during the run-in period.

Mileage (km)	Speed (MPH)
0-500	<15
500-1000	<22
1000-1500	<30



**CAUTION**

Please strictly observe the run-in requirements while riding a new scooter.

Avoid riding at constant speed for long period of time during the run-in period.

**8. Periodical maintenance**

To prolong the service life of your scooter, please make periodical inspection and maintenance of the scooter according to Periodical Maintenance Chart. If your scooter is often ridden on poor roads, alter this time schedule of some items to shorter intervals in order to ensure the reliability of the scooter.

**CAUTION**

After a new scooter has been ridden its first 500km or for the first month, check and service the scooter.

A careful check of certain equipment must be made after periods of storage.

Items	Odometer reading													Daily safety
	300	1000	2000	3000	4000	5000	6000	7000	8000	9000	10000	11000	12000	
Engine oil														I
Oil filter*	C			C				C				C		
Gear oil*	R				R						R			
Spark plug	Clean every 2000km, and replace with a new one if necessary													
Air cleaner	Clean the filter element every 1000km, and replace with a new one if necessary													
Air valve*	A				A				A					A
Cam chain*	A				A				A					A
Carburetor*					I				I					I
Fuel screener*						I				I			R	
Braking system	I	I	I	I	I	I	I	I	I	I	I	I	I	I
Driving chain*	I			I				I					I	
Driving belt*									I					
Screws nuts	T					T						T		
Cable lubrication						I						I		
Oil pump	I	I	I	I	I	I	I	I	I	I	I	I	I	
Carbon on cylinder and piston				C			C				C			C
Starter motor, Generator*													I	

Note: Go to a repair station to service the items marked

with an “\*”. Clean air cleaner.

Dust deposit is the main cause of engine power reduction and fuel consumption increase. Clean or replace regularly according to the periodical maintenance chart.

**How to clean**

**For foam plastic filter element**

Put the outer foam plastic filter element into non-flammable solution (such as soap water). Clean off the dust and foreign materials.

After cleaning, squeeze the element oil and squeeze it.

Soak it in the 4-stroke engine oil and squeeze it.

#### **For paper filter element**

Pat the paper filter element slightly to drop off the dust through shaking, or brush away the dust on the surface and in the slots of the element with soft brush.

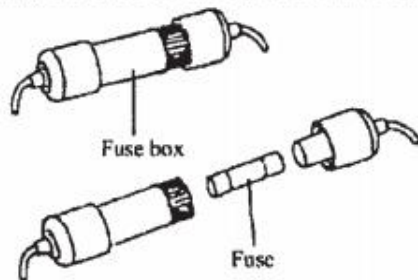

#### **CAUTION**

While washing, do not deform the filter element.

Never wash the paper filter element with water or fuel as detergent.

Replace the filter element if too dirty or damage.

Please clean and replace the filter element in accordance with the time or mileage schedule.

To assemble the air cleaner, if the cover or the filter element cannot be installed to their original position, the dust will be directly absorbed into the cylinder, which will cause wearing. The horsepower will reduce and the life of the engine will be affected.

While washing, do not let water enter the air cleaner to avoid abnormal start.

If it is often ridden on a hard, or if the fuel consumption increases obviously, please clean or replace the filter element at once.

#### **Maintenance and replace battery**

To ensure the battery is often in the best condition, the scooter adopts an auto rapid charging system.

Turn the ignition switch to “ ” before replacing the battery.

Make sure the +/- terminals of the new battery are correctly connected with the red and “-” terminal with the black lead.

When the scooter is not used for a period of time, remove the battery and store it in a cool, dark place.

Completely recharge the battery before reinstallation.

#### **Replace fuse**

Turn the ignition switch to “ ”.

The fuse can be seen in the fuse box near the battery.

Open the fuse box, and tighten the fuse box after replacement.

The specified fuse is 15A .

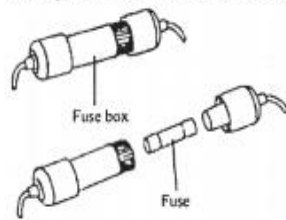

Fuse box

Fuse

### CAUTION

Inspect the cause of the burnt fuse and replace it. .

Do not use fuse of other size except the specified one.

### Check spark plug

The spark plug trouble is one of the cause of the difficulties for starting the engine. Excessive electrode erosion and electrode gap will make the sparking incomplete. .

Remove the spark plug with special spark plug wrench.

Check if the spark plug seat and electrode have greasy dirt, and if the electrode has carbon deposit and burnt. Greasy dirt and carbon should be cleaned immediately if found (with spark plug cleaner or needle brush ). If the spark plug accumulates much carbon and burns seriously, or the insulator cracks or comes off, replace it immediately.

Check the electrode gap of spark plug. Adjust the gap to the specified value if needed. If it is unable to adjust, replace it. .

Screw the spark plug in first with your hand, then tighten it with special spark plug wrench.

### The specified spark plug:

(TORCH) A7RTC

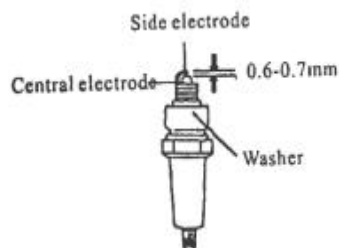

Side electrode

Central electrode

0.6-0.7mm

Washer

### CAUTION

The temperature of the working engine is very high, beware of being scalded.  
Do not use the spark plug of other model except the specified one.

### Replace engine oil

Replace the engine oil after the first 300km. From then on, replace it every 1000km. Check the oil level every 500km. If insufficient, add the specified engine oil.

Place the scooter on the center stand on a level surface. Warm up the engine for about 5 minute, then remove the dipstick and drain screw. Take out the oil strain the engine oil.

Install the oil strainer after cleaning. Wipe the drain screw clean and reinstall it by tightening.

Fill the specified 4-stroke engine oil (see page 19). The amount of the engine oil is about 0.9L. Insert and fasten the dipstick.

Warm up the engine, then stop it for 10 to 20 seconds. Check the oil level with the dipstick to ensure the oil level is above the specified upper limit. (See page 19 for how to check.)

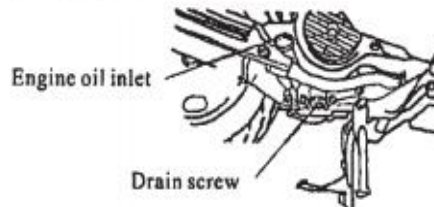

engine oil inlet  
Drain screw

### CAUTION

Please use the specified four-stroke engine oil. Do not use other grade engine oil or deteriorated oil or mixed engine oil.

If you operate your scooter on the crushed stone road, for short distance, in cold area, or if it idles for a longer time, replace the engine oil ahead of time schedule.

While refilling, do not exceed the upper limit of the dipstick.

When warming up the engine to replace the engine oil. Beware of scalded.

### Replace gear oil

Replace the gear oil after the first 300km. From then on, replace it every 5000km or six months. Please use the specified gear oil-85w/90 nSh0350.

Please the scooter on the center stand on a level surface, warm up the engine for about 3 minutes and stop it.

Screw off filling screw ( filler cap ) and drain screw to exhaust the original gear oil. Fasten the drain bolt after cleaning. Refill the new specified gear oil about 110 ml from the inlet hole.

Install and tighten the filling screw ( filler cap ).



**Drain screw    Filler cap**

Drain screw

Filler cap

**CAUTION**

If you often operate your scooter in rains, for long distance and distance and with excessive load, you should shorten the mileage and time of replacement.

Please use the specified gear oil. Do not use other gear oil or deteriorated oil or mixed gear oil.

Tighten the drain screw and filling screw ( filler cap ). Be careful of oil leak. Beware of scaled during oil replacement.

**Idle speed adjustment**

To adjust the idle speed, put up the center stand to raise the rear wheel off the ground.

After the engine is started, preheat it for 2-3 minutes.

Loosen or tighten the adjusting screw A to adjust the idle speed to 1700 A 100r/min. .

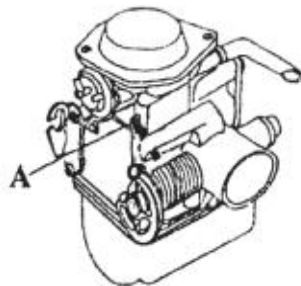

**CAUTION**

Turn "A" counter clockwise, the idle speed will reduce, otherwise increase.

The idle speed adjusting screw has already been adjusted to the best status before ex-factory. Do not adjust it.

**General lubrication**

Visually check if all lubrication points of the scooter body are well lubricated ( see page 26 for details ).

## 9. Troubleshooting

If you have no experience of maintenance, do not disassemble and service your scooter by yourself (especially the engine). Otherwise, the service life of your scooter may be shortened. Ask a Lifsan dealer or repair station for troubleshooting.

Case	Cause analysis	Troubleshooting
Starting hard or Cannot start	<ol style="list-style-type: none"> <li>1) Abnormal operation.</li> <li>2) Fuel tank empty.</li> <li>3) Fuel line clogged.</li> <li>4) Fuel dirty or containing water.</li> <li>5) Air cleaner clogged.</li> <li>6) Carbon deposit on the exhaust hole and muffler, and muffler clogged.</li> <li>7) Spark plug loose and leaking</li> <li>8) Connecting surface of cylinder block and cylinder head leaking.</li> <li>9) Spark plug faulty.</li> <li>10) Spark plug cap connected badly.</li> </ol>	<ol style="list-style-type: none"> <li>1) Operate according to this manual.</li> <li>2) Refuel.</li> <li>3) Check and get line through .</li> <li>4) Clean the fuel tank, and replace the fuel. .</li> <li>5) Clean the filter element.</li> <li>6) Clean and get it through .</li> <li>7) Tighten .</li> <li>8) Tighten cylinder head nut or replace gasket.</li> <li>9) according to the requirements on page 30.</li> <li>10) Adjust or replace.</li> </ol>
	Others	Go to the repair station for troubleshooting.

Case	Cause analysis	Troubleshooting
Engine stops while Throttling	The mixed gas too thin or the carburetor Pilot outlet clogged.	Go to the repair station to adjust it and get the carburetor through .
Engine stops At low speed	Fuel pipe and gas line blocked	Clean and get them through.
Starting but Running Irregularly	Others <ol style="list-style-type: none"> <li>1) Fuel line clogged.</li> <li>2) Spark plug electrode fouled with Carbon depositor dirty oil.</li> <li>3) Carbon deposit on exhaust hole and Muffler.</li> <li>4) Engine runs with overload</li> <li>5) Too much dirt on fan.</li> <li>6) Too much oil dirt on radiating Blades of cylinder.</li> <li>7) Engine oil insufficient.</li> </ol>	Go to the repair station for troubleshooting <ol style="list-style-type: none"> <li>1) Get it through</li> <li>2) Clean.</li> <li>3) Clean.</li> <li>4) Cool engine, and avoid long time running at high speed.</li> <li>5) Wash.</li> <li>6) Wash.</li> <li>7) Refill specified engine oil.</li> </ol>

	Others	Go to the repair station for troubleshooting.
Case	Cause analysis	Troubleshooting
Automatically stop	1) Fuel exhausted or fuel line clogged. 2) Engine runs with overload. 3) Too much dirt on the radiating blades of fan and cylinder. Others	1) Refill or get fuel line through. 2) Cool engine and avoid long time running at high speed. 3) Wash. Go to the repair station for troubleshooting.
Brake not good	1) Brake shoe excessively worn fluid insufficient. 2) Free and not properly adjusted.	1) Replace brake shoe or refill brake fluid. 2) Adjust to the specified value.
	Others	Go to repair station for troubleshooting.

Case	Cause analysis	Troubleshooting
Shock absorber In bad condition	Excessive dirt on shock absorber That relevant movement blocked	Clear off the dirt.
	Other	Go to the repair station for troubleshooting.
As for other troubles, please go to repair station for troubleshooting.		

## 10. Specifications

Item		Specifications
Dimensions	Overall length x width x height	2040mm × 730mm × 1150mm
	wheel base	1430mm
	Ground clearance	≥80mm
Weight	Net weight	100kg
	Payload weight	180kg
	Gross weight	280kg
Performance	The maximum speed	≥53mph
	Economic consumption of fuel	≤2.9L/100
	Grade angle	≥6°
	Caster angle	26°
	Turning circle diameter	≤4000mm
	Maximum noise	≤78dB(A)

Item	Specifications
The engine	Model Type



	Bore x Stroke	57.4*57.8mm
	Displacement	149.6ml
	Compression ratio	9.5:1
	The rated power	6 kw 7000±350min)
	The maximum torque	8.5Nm/6500±225 (r/min)
	Carburetor	CDI
	Ignition type	Electric or kick start
	Starting type	Foreed Splash
	Lubrication type	

Item		Specifications
Drive system	Drive type	Belt drive
	Clutch	Dry centrifugal
	Transmission	Stepless
	Geat ration	7.657-18.423
Frame		Welded with seamless steel pipe
Suspension	Front shock absorber	Hydraulic
	Rear shock absorber	Hydraulic spring
Brake		Front:disc /drum Rear:drum
Capacity of tank		6.0L

Item		Specifications
Electric system	Starter motor	12V 0.3Kw
	Generator	A. C.
	Battery	12V 6Ah
	Headlight/city light	12V 25W/25W /12V 3W
	Front turning light	12V 10W
	Rear turning light	12V 10W
	Brake /taillight	12V 21W/5W
	Horn	12V 1.5A

#### 11. Wiring diagram

- |                        |               |
|------------------------|---------------|
| 1. Engine stop switch  | 2. Generator  |
| 3. Regulator/Rectifier | 4. Enricher   |
| 5. Igniter             | 6. Spark plug |
| 7. Ignition coil       | 8. Fuse       |
| 9. Ignition switch     | 10. Battery   |

- |                                       |                                      |
|---------------------------------------|--------------------------------------|
| 11. Starter                           | 12. Starter motor                    |
| 13. Electric starter switch           | 14. Horn switch                      |
| 15. Turn signal switch                | 16. Flasher                          |
| 17. Voltage sensor                    | 18. Fuel gauge                       |
| 19. Front brake light switch          | 20. Rear brake light switch          |
| 21. Dimmer switch                     | 22. Horn                             |
| 23. Front left turn signal light      | 24. Rear right turning light         |
| 25. Right turn signal indicator light | 26. Left turn signal indicator light |
| 27. Rear left turn signal light       | 28. Front left turn signal light     |
| 29. Voltage indicator light           | 30. Fuel sensor                      |
| 31. Brake/tail light                  | 32. Meter light                      |
| 33. City light                        | 34. Headlight                        |
| 35. High beam indicator light         |                                      |

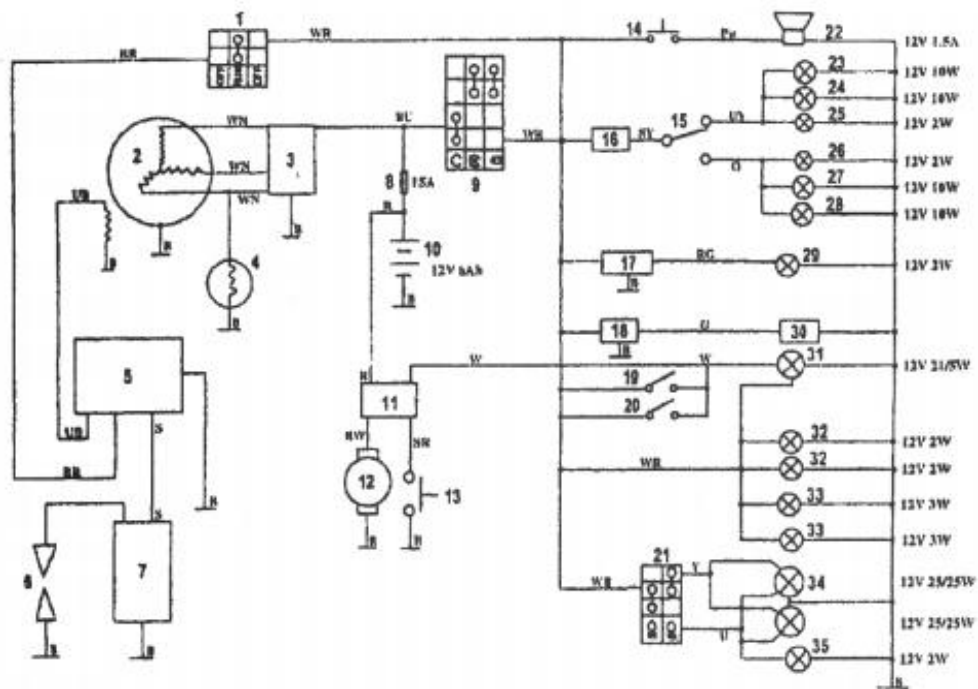

Color	Red	Yellow	White	Black	Brown	Green	Blue	Grey	Orange	Pink	Purple
Code	R	Y	W	B	N	G	U	S	O	P	Pu

Color	Red	Yellow	White	Black	Brown	Green	Blue	Grey	Orange	Pink	Purple
Code	R	Y	W	B	N	G	U	S	O	P	Pu